

Description

CS3-RS Resistance Indicator has been designed with high accuracy \ display \ control \ remote communication.

A compact body design for small equipment, laboratory instrument, and others.

Also are available with relay output, analog output, RS485 Modbus RTU communication to cover a wide range of applications.



Features

1. Measuring range : 0~200Ω/2000Ω/20.0KΩ/200.0KΩ (2 wire)
2. Field calibration with resistance to meet the system requirement
3. Relay output can be set to Hi / Lo / Hi Hold /Lo Hold / DO mode and can setting as Start delay band / Hysteresis band / Delay on & Delay off function
4. Analog output or RS485 communication are optional
5. External control input can be set to PV Hold / Max or Min value reset / Relay Reset
6. CE and FCC approved

Application

Testing Equipments for resistance (as like as coil of motor, transformer, relay...) measuring, Alarm, Control and Communication with PC/PLC Components of resistance online testing station.

Ordering Information

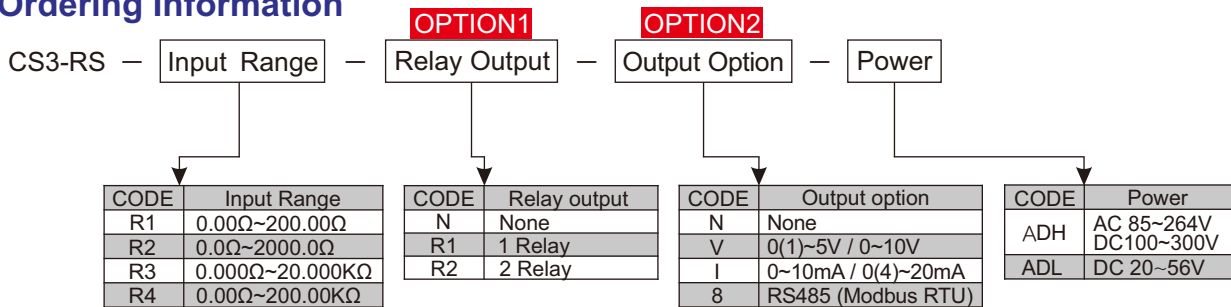

Technical Specification

Measuring Range	Input Resistance
0.00Ω~200.00Ω(2 wire)	≥1MΩ
0.0Ω~2000.0Ω(2 wire)	
0.000Ω~20.000KΩ(2 wire)	
0.00Ω~200.00KΩ(2 wire)	

Input	
Calibration	Digital calibration
Field calibration	Calibration with sensor input high & low to meet system structure
A/D converter	16 bits resolution
Accuracy	$\leq \pm 0.04\%$ of FS ± 1 count
Sampling rate	15 times / sec
Response time	$\leq 100\text{mS}$ (when R.U.C. = "1")

Display & Functions	
LED	4 $\frac{2}{3}$ digits , 0.4" (10.0mm) red high - brightness LED Relay output indication: square red LED RS485 communication: square orange LED ECI indication: square green LED
Display range	-19999~29999
Scaling function	[L o S] Low scale; Settable range: -19999~+29999 [H i S] High scale; Settable range: -19999~+29999
Decimal point	0/0.0/0.00/0.000 / 0.0000
Over range indication	[o u F L] Over 20% of input Hi limit value
Under range indication	[- o u F L] Under 20% of input Low limit value
Max /Min recording	Maximum and Minimum value storage during power on
Display functions	PV / Max(Min) value Hold / RS485 programmable
Front key functions	Down key can be set same as ECI function
Low cut	- 19999~29999 counts
Digital fine adjust	PV zero [P u . P r o] -19999~29999 PV span [P u . S P n] -19999~29999
Reading Stable Functions	
Average	[R u C] 1~99 times
Moving average	[m . R u C] 1~10 times
Digital filter	[d . F . L t] 0~99 times

Relay Output (Option)	
Set points	2 Set points, range: -19999~29999
Relay contact form	2 Sets SPDT (1c), 2A/250Vac
Relay action mode	Hi / Lo / Hi.HLd / Lo.HLd / DO
Relay action function	Each Relay can set Start delay / Delay off time / Hysteresis Start band setting: 0~9999 counts Start delay time setting: 0:00.0~9(Min)~59.9(Sec) Active delay time setting: 0:00.0~9(Min)~59.9(Sec) Delay off time setting: 0:00.0~9(Min)~59.9(Sec) Hysteresis setting: 0~5000 counts
External Control Input (ECI)	
Input mode	One Channel input , mechanical contact or open collect input are available
Input function	Tare / PV Hold / Max. or Min. value reset / DI / Relay reset
Debouncing time	5~255 x (8mS) programable
Analog Output (Option)	
Accuracy	≤±0.1% of F.S. ; 16 bits DA converter
Ripple	≤±0.1% of F.S.
Response time	≤100 mS. (10~90% of input)
Output range	Voltage output: 0~5V / 0~10V / 1~5V Current output: 0~10mA / 0~20mA / 4~20mA
Output capability	0~10V : ≥1000Ω 4(0)~20mA : ≤ 600Ω max
Scaling	[R o H 5] Output High setting : - 19999~29999 [R o L 5] Output Low setting : - 19999~29999 [R o L n t] Output High Limit: 0.00~110.00%
Digital fine adjust	[R o P r o] adjust range : - 38011~+27524 [R o S P n] adjust range : - 38011~+27524
RS485 Communication (Option)	
Protocol	RS485 Modbus RTU mode
Baud rate	1200/2400/4800/9600/19200/38400
Data bits	8 bits
Parity	None / Even / Odd
Stop bits	1 or 2
Address	1~247 programmable
Distance	1200M max
Terminate resistor	120~300Ω/0.25W(typical: 150Ω)

Power Supply	
Range	ADH: AC 85~264V ; DC 100~300V ADL: AC/DC 20~56V
Power consumption	AC: ≤8VA @ 230V / DC: ≤3W
Memory storage	EEPROM
Safety	
Isolation	AC 2KV, 50/60Hz, for 1 min, Between Power / Input / Output / Case
Insulation resistance	≥100MΩ @ 500Vdc, Between Power / Input / Output / Case
EMC	EN61326: 1:2013 / CISPR11 Class A EN61000-3-2: 2014 / EN61000-3-3: 2013 IEC61000-4-2: 2008 IEC61000-4-3: 2006+A1: 2007+A2: 2010 IEC61000-4-4: 2012/IEC 61000-4-5: 2005 IEC61000-4-6: 2013 / IEC61000-4-8: 2009 IEC61000-4-11: 2004
LVD	EN61010-1: 2010
FCC	FCC part 15 subpart B: Class A
Environmental Characteristics	
Operating Temp.	0~60°C
Humidity rating	20~95%RH, Non-condensing
Temp. coefficient	≤100 PPM/°C
Storage Temp.	-10~70°C
IP Enclosure	Front panel: IEC 529 (IP52) ; Housing: IP20
Mechanical Characteristics	
Dimensions	48mm(W)x24mm(H)x107mm(L)
Panel cutout	45mm(W)x22.5mm(H)
Case material	ABS (with fire-retardant)
Mounting	Panel mounting
Terminal block	PA 66 (UL 94V-0) AWG 28~14 / 0.5~1.5mm ² Screw Torque Value: M2.0 / 2.0kgf.cm(Max)
Weight	110g

Front Panel

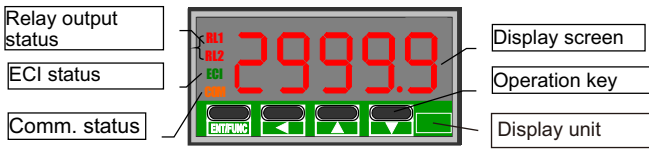

Dimension

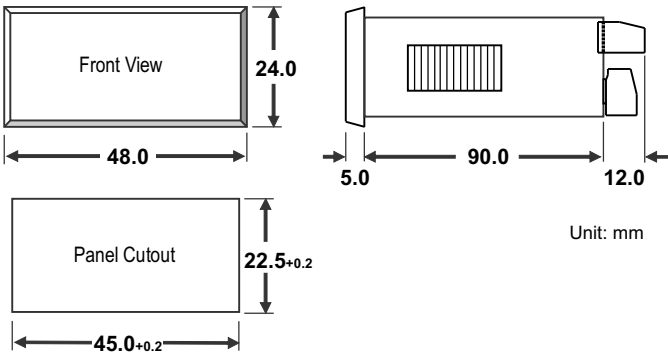

RS485 Communication Port

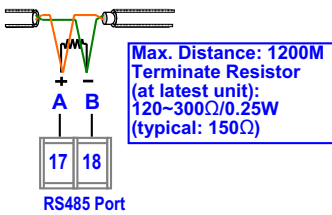

Installation

! The meter should be installed in a location that does not exceed the maximum operating temperature and provides good air circulation.

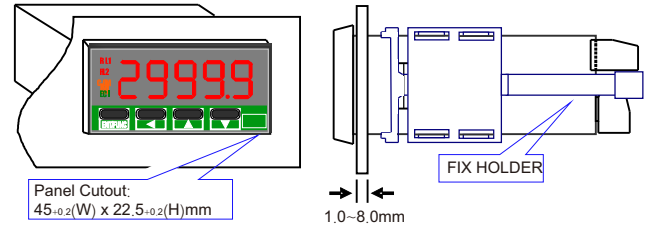

Connection Diagram

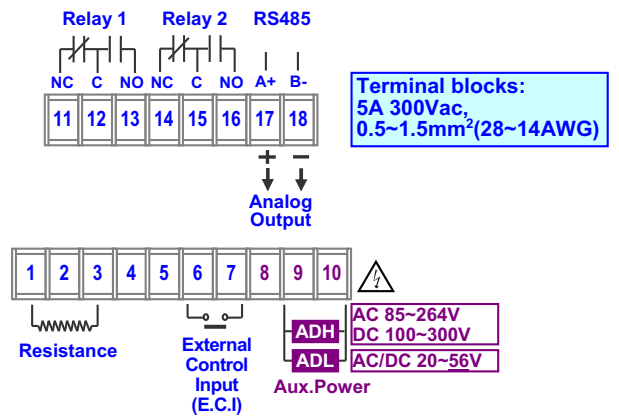

! Please check the voltage of power supplied first, and then connect to the specified terminals. It is recommended that power supplied to the meter be protected by a fuse or circuit breaker

