

CS2-VA VOLTAGE/CURRENT METER RELAY
CS2-PR DC SIGNAL 10V/20mA INDICATOR
CS2-SG LOAD CELL/STRAIN GAUGE INDICATOR
CS2-PM POTENTIOMETER INDICATOR
CS2-RS RESISTANCE(2-W) INDICATOR
CS2-T TEMPERATURE INDICATOR
OPERATION MANUAL



INDEX

■ DESCRIPTION	1/41
■ FEATURES	1/41
■ APPLICATIONS	2/41
■ FUNCTION DEFINE & DESCRIPTION	2/41
■ Character Symbol	2/41
■ Input & Scaling	2/41
■ Input Range	2/41
■ Input type(CS2-PR only)	2/41
■ Scaling Function	2/41
■ Display Functions	3/41
■ Max / Mini recording	3/41
■ Maximum Hold or Minimum Hold for PV	3/41
■ PV(Present value) Hold	3/41
■ Relative PV(Δ PV) or Tare	3/41
■ Remote display by RS485 command	3/41
■ Low Cut	3/41
■ Digital Fine Adjustment	4/41
■ Square root function	4/41
■ Reading Stable Functions	4/41
■ Average Display update	4/41
■ Moving Average	4/41
■ Digital filter	4/41
■ Relay Functions	5/41
■ Relay energized mode Hi / Lo / Go-1.2 / Go-2.3 / Hi.HLd / Lo.HLd / DO	5/41
■ Start delay	5/41
■ Hysteresis	5/41
■ Relay energized delay	5/41
■ Relay de-energized delay	5/41
■ 3 External Control Inputs(E.C.I.)	6/41
■ Relative PV(Δ PV) or Tare	6/41
■ PV Hold	6/41
■ Reset for Maximum or Minimum Hold	6/41
■ DI(Digital input)	6/41
■ Reset for relay energized latch	6/41
■ Bank selection(for CS2-VA/CS2-RS)	6/41
■ Analogue Output Functions	6/41
■ Relate on various display value	6/41
■ High Limited for Analog Output	6/41
■ Fine Zero & Span Adjustment for Analog Output	6/41
■ RS 485 Communication	7/41
■ Remote Display function	7/41
■ Field Calibration (for CS2-SG / CS2-PM / CS2-RS)	7/41
■ Bank Function(Suffix-3BK) for CS2-VA, CS2-RS	8/41
■ ORDERING INFORMATION	9/41
■ INSTALLATION	10/41
■ Dimensions & Panel Cut Out	10/41
■ Installation	10/41
■ Wiring Diagram	10/41
■ OPERATIONS	12/41
■ Front Panel	12/41
■ Operating Key	13/41
■ Error Message	13/41
■ Operating Flow Chart	14/41
■ Operating Steps	18/41
■ User Level	18/41
■ Programming Level	19/41
Input Group	20/41
Relay Group	23/41
External Control Input(E.C.I.) Group	26/41
Analogue Output Group	27/41
RS485 Group	28/41
Field Calibration Group	29/41
■ TROUBLE SHOOTING	31/41
■ RS485 MODBUS RTU MODE	34/41
■ ADDRESS TABLE	34/41
■ User Level	34/41
■ Programming Level	35/41
[Input Group]	35/41
[Relay Group]	35/41
[ECI Group]	36/41
[AO Group]	37/41
[RS485 Group]	37/41
■ DISCLAIMERS	37/41
■ TRADEMARK	37/41

■ ADDRESS TABLE For 5-digit Display		38/41
■ User Level	-----	38/41
■ Programming Level	-----	38/41
[Input Group]	-----	38/41
[Relay Group]	-----	39/41
[EI Group]	-----	40/41
[AO Group]	-----	40/41
[RS485 Group]	-----	41/41

**CS2-VA
CS2-PR
CS2-SG
CS2-PM
CS2-RS
CS2-T**

**VOLTAGE / CURRENT METER RELAY
DC SIGNAL (20mA/10V) INDICATORS
STRAIN GAUGE / LOAD CELL INDICATORS
POTENTIOMETER INDICATORS
RESISTANCE (2 W) INDICATORS
TEMPERATURE INDICATORS
OPERATION MANUAL**

DESCRIPTIONS

For the various measuring requirement, the CS2 series' R&D is destined with high accuracy measurement, display, control and communication (Modbus RTU mode) such as AC voltage/Current, DC process signal 0~10V/4~20mA(with square root function), Strain Gauge/Load Cell, Potentiometer, Resistance, Temperature and so on.

The CS2 series designed with 3 external control input (ECI) in standard version and the extra optional with 4 Relay, 1 Analogue and 1 RS485 port which it's available all-in-one together with the display functions, beside above it still available extra the programmable such as max/mini hold, PV hold, relative PV.....etc that it's more flexible & more useful in the testing equipment field & others' territories.

In applications, they are not only indicators but also the I/O interfaces which it's compatible with any systems. ADtek built-in the innovation concept for External Control input(ECI) and Relay output similar as I/O module of PLC. It's very simply & easily to achieve remote monitoring and control simultaneously.

FEATURES

- User friendly, easily programmable operated smoothly by the front panel
- 3 external control inputs in standard for Relative PV(Δ PV or Tare) / PV Hold / Maximum or Minimum Hold / DI / Reset for Relay Energized Hold....
- 4 relay in option for Hi / Lo / Hi Latch / Lo Latch / Go / DO energized with Start Delay / Hysteresis / Energized & De-energized Delay / Relay Energized Hold..... functions
- Analogue output and RS 485 communication port are optional.

[CS2-VA VOLT / CURRENT METER RELAY]

- Measuring Voltage 0~600V or Current 0~10A ; DC / AC / TRMS
- Accuracy: AC: $\pm 0.1\%$ f.s.; DC: $\pm 0.04\%$ f.s.; Display Range: -19999~+29999
- 4 banks pre-set in option for all relay functions are relative to 4 difference scaling, and be selectable by 3 External Control Inputs (ECI) or front key.

[CS2-PR DC SIGNAL INDICATOR]

- Measuring DC 0~10V or 0(4)~20 mA(with square root function) in one indicator(input code: AV)
- Accuracy: $\pm 0.04\%$ f.s.; Display Range: -19999~+29999

[CS2-SG STRAIN GAUGE INDICATOR]

- Measuring ranges of Load Cell or Strain Gauge from 0~1.0/~2.0/~4.0 mV/V or 0~10.0/~20.0/~40.0 mV/V and specified with excitation supply DC 5V or 10V, 40mA.
- Accuracy: $\pm 0.04\%$ f.s. ; Display Range: -19999~+29999
- Field calibration of load cell or strain gauge to meet the system requirement with high/low calibrations which it saved the test time and keep accuracy

[CS2-PM POTENTIOMETER INDICATOR]

- Measuring Potentiometer 0~50 Ω /~2.0K Ω ; 0~2.0K Ω /~100.0K Ω (3 wires)
- Accuracy: $\pm 0.04\%$ f.s. ; Display Range: -19999~+29999
- Field calibration of potentiometer to meet the system requirement with high/low calibrations which it saved the test time and keep accuracy



[CS2-RS RESISTANCE INDICATOR]

- Measuring Resistance 0~200.00Ω/2000.0Ω/20.000KΩ/200.00KΩ (2 wires)
- Accuracy: ± 0.04% f.s. ; Display Range: -19999~+99999
- Field calibration of resistance to meet the system requirement with high/low calibrations which it saved the test time and keep accuracy
- 4 banks pre-set in option for all relay functions are relative with 4 difference scaling, and be selectable by 3 External Control Inputs (ECI) or front key.

[CS2-T TEMPERATURE INDICATOR]

- Measuring Pt100Ω; T/C: K,J,E,T(the range will be fix, please specified the exactly input type in ordering)
- Accuracy: Pt100: ± 0.1% f.s.; T/C: ± 0.2% f.s.; Display Range: -19999~+29999

■ APPLICATIONS

■ Models

- **CS2-VA** Switch Boards / Motor Control / Machinery / Testing Equipments
- **CS2-PR** Machinery Control / Process Control Systems for pressure, level,.....sensing transducers Automation System / Testing Equipments
- **CS2-SG** Weighting indication, control and Alarm / Machinery Control / Tension and others test equipment
- **CS2-PM** Position indication, control and Alarm / Machinery Control / Angle of Value Control / Tap of transformer indication
- **CS2-RS** Resistance test as like as coil of transformer or motor indication
- **CS2-T** Temperature measuring

■ Functions

- **Safety & Protection** Hi/Lo alarm and latch($\overline{H.HLd}$ / $\overline{L.oHLd}$), Analogue output limited($\overline{R.oL.nE}$)
- **Testing & Measuring** Maximum/Minimum hold($\overline{H.R.Hd}$ / $\overline{M.in.Hd}$), PV hold($\overline{P.u.HLd}$), Relative PV/Tare/ Δ PV($\overline{r.EL.P.u}$), Banks($\overline{b.nE}$), Field calibration with sensor
- **Remote Monitoring & Control** RS485 communication port, Remote display($\overline{r.5485}$), Remote monitoring($\overline{d.i}$) and Remote control for Relay energized($\overline{d.o}$)

■ FUNCTION DEFINE

■ Character Symbol

A	b	C	d	E	F	G	H	i	J	K	L	M
R	b	C	d	E	F	G	H	i	J	K	L	n
n	o	P	q	r	S	t	U	v	W	X	y	Z
n	o	P	q	r	S	t	U	v	W	X	y	Z
1	2	3	4	5	6	7	8	9	0	/	.	
i	2	3	4	5	6	7	8	9	0	r	.	

■ Input & Scaling

■ Input Range

Programming range: 0.00~100.00% of input range

The meters had been set the input range as per order code (ex. 0~10V or 4(0)~20mA) in factory. If the meters requested to convert into difference inputs ranges, the meters can be switched function [R.L.o] and [R.H.i] in [INPUt GROUP] to meet the input signal. For example:

The meter is 0~10Vdc input, and the signal from sensor is 2~10Vdc. Please enter into the [INPUt GROUP] to set [R.L.o] (Analogue input Low) to be 20.00% (10V x 20.00% = 2V), then the meter has been converted the input range into 2~10Vdc and the all relative parameters be processed by 2~10V.

■ Input type [R.EYP] for CS2-PR

**Programming range: Voltage:0~10V/0~5V/1~5V;
Current: 4~20mA/0~20mA/0~10mA**

It supports dual type input 0~10V and 0(4)~20mA between 3 terminals in one meter. Please specify the

ordering code AV for input range. And, programming the function [R.EYP] to co-ordinate with the input range and wiring terminals.

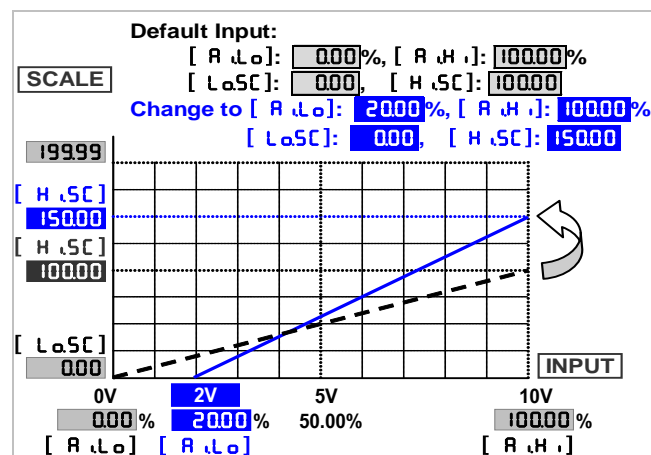

*Lower resolution display may be caused by the setting the less decimal point such as "100". If requested high resolution must with more decimal point such as "100.00".

■ Scaling Function [L.oSC] & [H.iSC]

Programming range: -19999~+29999counts

Setting the [L.oSC](Low scale) and [H.iSC] (High scale) in [INPUt GROUP] which are relative to input signal. Reverse scaling will be set too. Please refer to the below figures as following,

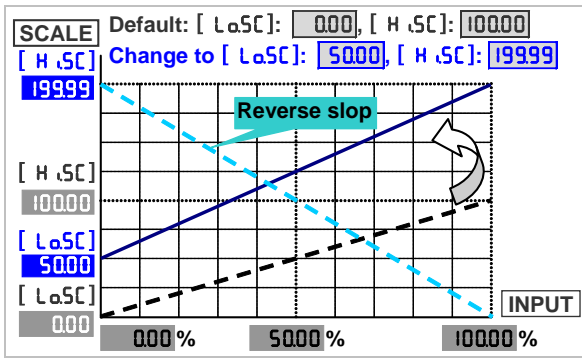

*Lower resolution display may be caused by more narrow scale. If the [A.L.O.] & [A.H.I.] have been changed, the [L.S.C.] & [H.S.C.] will be related to the new setting of [A.L.O.] & [A.H.I.].

Display Functions

Max / Mini recording

In order to review & trace the drifting PV, the meters will keep the values of maximum and minimum in [user level] during power on. User can reset the values by [Reset] in [user level]. And it'll record new maximum and minimum value immediately after reset.

Display function [dSPly] for display screen

The [dSPly] function in [INPUT GROUP] can be set to show present value [PV], Maximum Hold [Max Hold] or Minimum Hold [Min Hold] or Remote display by RS485 command [5485]. Please refer to following for detail.

Present value [PV]

Display screen will show the value that is relative to input and [L.S.C.] (Low scale) and [H.S.C.] (High scale) setting.

Maxi. Hold [Max Hold] or Mini.m Hold [Min Hold] for PV

When the [dSPly] function in [INPUT GROUP] set to be [Max Hold] (Max. Hold) or [Min Hold] (Mini. Hold), that the meter will still display the value of PV in maximum (or minimum) and the relative square orange LED will be bright during power on, With manual reset as below:

- 1) By front key in [user level], Up/Down Key function set.
- 2) ECI terminals closed.

The meter will update immediately new maximum (minimum) values after ECI is opened, or press Up/Down Key again. The Reset functions will be described in ECI functions.

Please paste the sticker on the right side of orange square LED to identify the status of display.

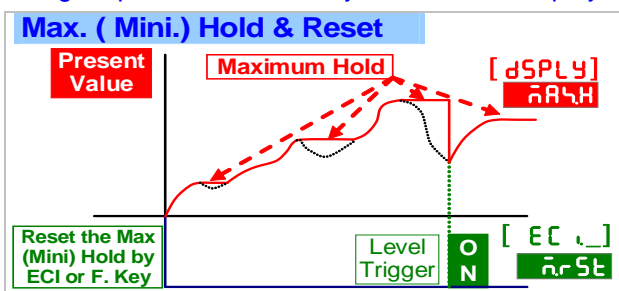

Remote display [5485] by RS485 command

In past, The meter normally receive 4~20mA or 0~10V from AO card or BCD card of PLC. We built-in a new solution by RS485 which it can writing the value to the display screen so that saving costs of AO and wiring connecting to PLC simultaneously.

When the [dSPly] function set to be [5485], the LED display no longer appear the input signal on the meter then the PV screen will display the data from RS485 command. The data (number) will be same function as PV which it will compare with set-point, analogue output and ECI functions.

PV (Present value) Hold [PV Hold]

When the [EC I] (External Control input) set to be [PV Hold] (PV Hold) function in [EC I GROUP], that display will be hold & kept, and the relative green LED will be bright, when the ECI terminals been closed or pressed Up/Down Key function been set (the 1st times), until the ECI is to be opened or press Up/Down Key again (the 2nd times).

Please paste the sticker on the right side of green square LED of ECI to identify the status of display.

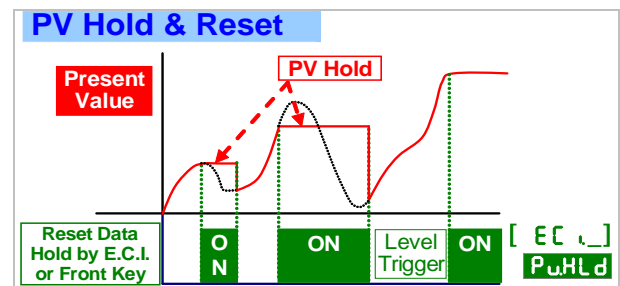

Relative PV (ΔPV) or Tare [REL PV]

The [EC I] can be set to be [REL PV] (Relative PV) function. When the ECI is closed, the reading will show the differential value with PV or Tare either.

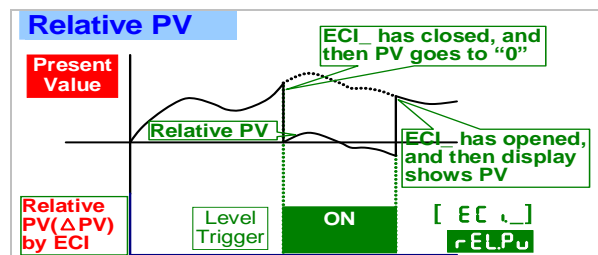

Low Cut [L.C.Ut]

Settable range from -19999~+29999 digits.

The users can set the value range.

- 1) if set the positive value (X1) here to display "0" which it expressed to be low-cut the PV between "+X1 (plus)" & "-X1 (minus)" / absolute value
 $PV < | \text{Setting value (X1)} |$, the display will be shown 0
 EX: Low Cut is set for 0.50. If the display is from -0.50~+0.50, that will be 0.

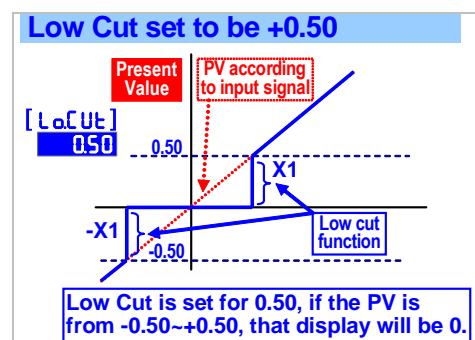

- 2) If set the negative value (X2) here to display "X2" which it expressed to be low-cut the PV that it's under the X2 setting value;
 $PV < \text{Setting value (X2)}$, the display will be shown X2.

EX: Low Cut is set for -0.01. If the display is < -0.01, and all the display will be -0.01.

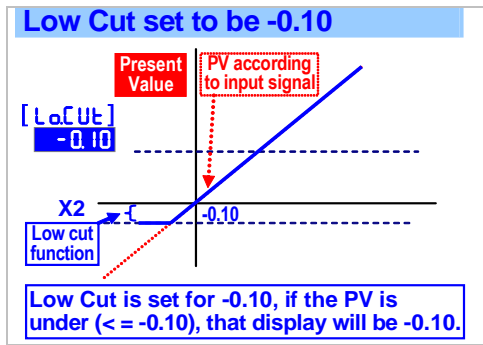

Digital Fine Adjustment [P_uP_r_o] & [P_uS_P_n]
Settable range from -19999~+29999 ;

Users can get "Fine Adjustment PV" by front key on the meter for lower and/or higher points. "Just Key-In" the value, if user wants to show the value in input signals currently.

Especially, the [P_uP_r_o] & [P_uS_P_n] are not only in zero & span of PV, but also randomly lower point in function [P_uP_r_o] & randomly higher point in function [P_uS_P_n]. The meter will be auto-linearization for full scale.

The adjustment can be cleared in function [P_S_C_L_r].

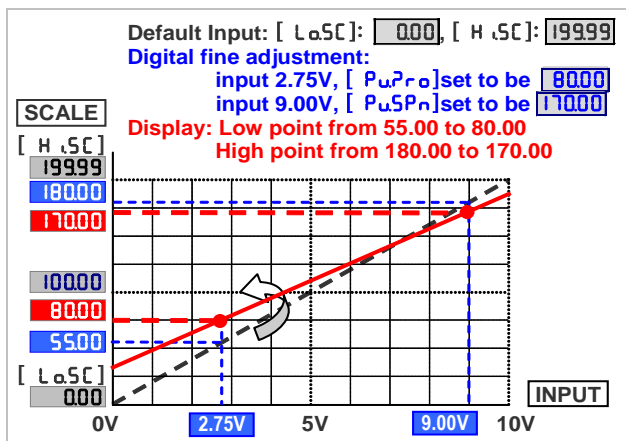

*Please make sure that the [P_uP_r_o] point must be less than [P_uS_P_n] during the process of digital fine adjustment. Generally, the interval should be over 50% of input range. If the interval is too narrow, that may be made bigger error between zero and span,

Square root function [S_q_r_o_t]

Selectable no or YES ;

The function can be set no or YES in [i_nP_U_T C_r_o_U_P] to measure the signal from differential pressure flow-meter. **The formula = $\sqrt{(P_v/H_S)} \times H_S$**

Reading Stable Functions

Average Display update [A_v_g]

Settable range: 1~99 times;

Jittery Display caused by the noise or unstable signal. User can set the times to average the readings, and to get smoothly display.

Remark: To set the average times with higher will make the response time slower of Relay and Analogue output.

The meter's sampling is 15cycle/sec

If the [A_v_g](Average) set to be to express the display update with 5 times/sec.

The meter will calculate the sampling 1-3 and update the display value. At meantime, the sampling 4-6 will be processed to calculate.

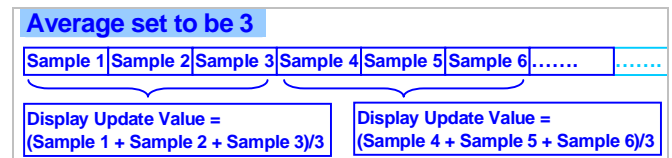

Moving Average update [M_o_v_i_n_g]

Settable range: 0(no function)/1~10 times;

Jittery Display caused by the reasons as like as noise or unstable signal. User can set the times to average the readings, and get smoothly display.

Remark: To set the moving average times with higher wouldn't affect the response time of Relay and Analogue output except the 1st updated display value will be slower.

The meter's sampling is 15cycle/sec. If the [M_o_v_i_n_g](Moving Average) set to be expressed the display update with 15 times/sec.,

In the first updated display value will be same as average function. In the next updated display value, the function will get the new fourth sample (sample 4) then throw away the first sample (sample 1) that the newest 3 samples(sample 2,3,4) will be calculated for the updated display value.

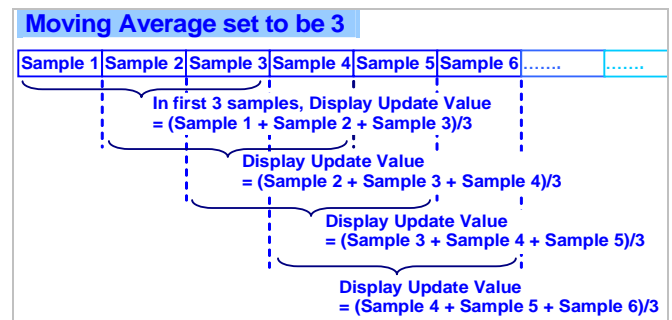

Digital filter [d_F_i_l_t_e_r]

Settable range from 0(None)/1~99 times.

The digital filter can reduce the influence of spark noise by magnetic of coil.

If the values of samples are over digital filter band(fixed in firmware and about 5% of stable reading) 3 times (Digital Filter set to be 3) continuously, the meter will admit the samples and update the new reading. Otherwise, it will be as treat as a noise and skip the samples.

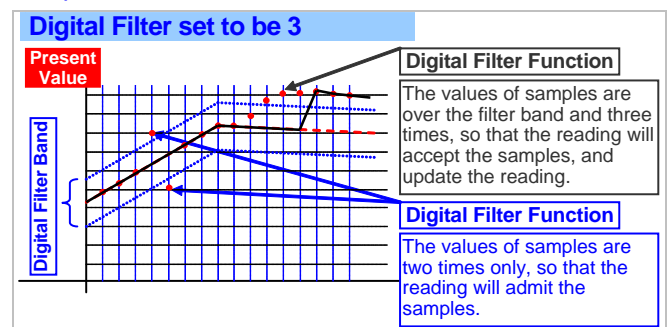

Relay Functions

CS2 series offer the 4 relay outputs with more flexible and multi-functions. They can be programmable individually in [rELRY Grop]. Please refer to the description as following;

Relay energized mode Hi / Lo / Go-1.2 / Go-2.3 / Hi.HLd / Lo.HLd / DO

- **Hi(Fig.1-①) (H):** Relay will be energized, when PV > Set Point
- **Lo(Fig.1-②) (Lo):** Relay will be energized, when PV < Set Point
- **Go-1.2(Fig.1-③) (Go-12):** This function is programmable for Relay 3 or 4 only. If the Relay 3 or 4 set to be Go function, the relay will compare between [rY1.5P] and [rY2.5P].

Go relay energized when the condition is [rY1.5P] (Hi) > PV > [rY2.5P] (Lo)

- **Go-2.3(Fig.1-③) (Go-23):** This function is programmable for Relay 4 only. If the Relay 4 set to be Go function, the relay will compare between [rY2.5P] and [rY3.5P].

Go relay energized when the condition is. [rY2.5P] (Hi) > PV > [rY3.5P] (Lo)

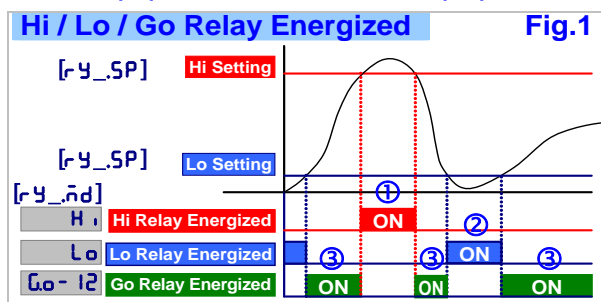

- **Hi alarm & latch / Lo alarm & latch (Hi.HLd / Lo.HLd)**

The relay energized with latched function is for electrical safety and human protection.

For example, a current meter relay installed for the over current alarm of motor. Generally, over current of motor caused by over load, mechanical dead lock, aging of insulation and so on. Above cases will alarm in the meter, if the user doesn't figure out the real reason and re-start the motor. It may damage the motor. The functions of Hi.HLD & Lo.HLD are designed must be manual reset the alarm after checking out and solving the issue. It's very important idea for electrical safety and human protection.

As the PV Higher (or lower) than set-point, the relay will be energized to latch except manual reset by from key in [user level] or [ECI] (ECI) set to be [rY5E] is closed.

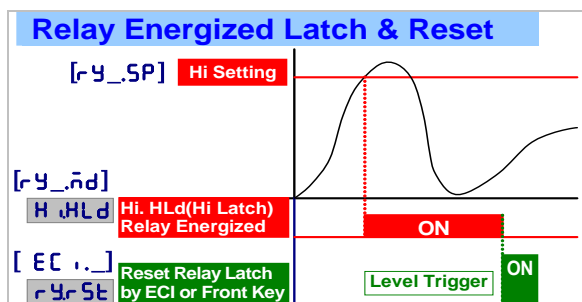

- **DO(Digital Output) (do)**

The function has been designed not only a meter but also an I/O interface. In the case of motor control cabinet can't get the remote function. It's very easily to get the ON/OFF status of switch from CS2 series with RS485 function.

If the [rY_nd] had been set do, the relay will be energized by RS485 command directly, but no longer to compare with set-point.

- **Start delay band [rY5b] and Start delay time [rY5d]**
The functions have Been designed for,
 1. To avoid starting current of inductive motor (6 times of rated current) with alarm.
 2. If the [rY_nd] relay energized mode had been set to be Lo(Lo) or Lo.HLd(Lo & latch). As the meter is power on and no input to display the "0" caused the relay will be energized. User can set a band and delay time to inhibit the energized of relay.

- **Start band [rY5b] (Fig.2-①):**

Settable range from 0~9999 Digits

- **Start delay time [rY5d] (Fig.2-②):**

Settable range from

0.0(second)~9(minutes)59.9(seconds);

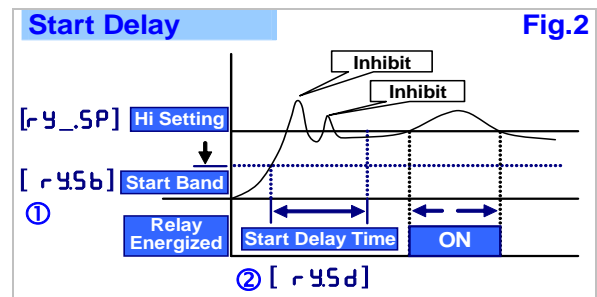

- **Hysteresis [rY_HY] (Fig.3-①)**

Settable range from 0~9999 Digits

As the display value is swing near by the set point to cause the relay on and off frequently. The function is to avoid the relay on and off frequently such as compressor.....etc.,

User can set a band to prevent from the relay on and off frequently

- **Relay energized delay [rY_r d] (Fig.3-②)**

Settable range from

0.0(second)~9(minutes)59.9(seconds);

The function is to avoid the miss action caused by noise. Sometime, the display value will swing caused by spark of contactor.....etc.. User can set a period to delay the relay energized.

- **Relay de-energized delay [rY_F d] (Fig.3-③)**

Settable range from

0.0(second)~9(minutes)59.9(seconds)

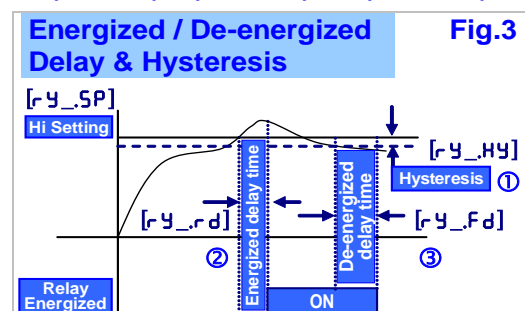

3 External Control Inputs(ECI)

CS2 series offers 3 point external control inputs (ECI). They can be programmable individual with multi display and control functions. The front key function can be set to execute ECI function, but ECI terminals will be disabling. The ECI terminal input was designed by level trigger. Please refer to description as below,

Relative PV(Δ PV) or Tare (REL.PV)

The [EC] can be set to the REL.PV (Relative PV) function. When the ECI is closed, the reading will show the differential value with PV. Please refer to Display function section previously.

PV(Present value) Hold (PV.HLD)

The [EC] can be set to the PV.HLD (PV Hold) function. The display will be hold when the E.C.I. is closed except the ECI is to be open. Please refer to Display function section previously.

Reset Maximum or Minimum Hold (RST) for PV

The [EC] function can be set to the RST function to reset the maximum and minimum value by terminal of ECI.

Especially, the dSPLY function in INPUT GROUP can be set to the MAX.HLD or MIN.HLD to operate in coordination with DO of PLC. It is easier to achieve the maximum value testing in automation. Please refer to the below figures.

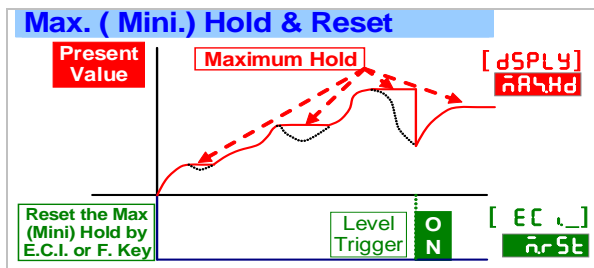

DI(Digital Input) (DI)

The [EC] can be set to the DI (Digital Input) function when the meter builds in RS485 port. The computer is easier to get a switch status through the meter as like as DI of PLC.

Reset for Relay Energized Latch (RST)

If the relay energized mode has been set to be H.HLD (High energized & latch), and the [EC] set to be RST (Reset Relay function). When the PV matches the condition of relay energizing, the relay will be energized with latch except the ECI terminal is closed.

Bank selection (BANK) (for CS2-VA/CS2-RS)

Please refer to the function section (page 8/38) of this manual.

Analogue Output Functions

Please specify the output type either 0~10V or 4(0)~20mA in ordering code. The output low and high can be programmable which it's related with various display values. Reverse slope output is decided by reversing point positions.

Output range selection ([RANGE])

Voltage output specified

Programming : 00-10(0~10V) / 00-5(0~5V) / 01-5(1~5V)

Current output specified

Programming : 04-20(4~20mA) / 00-20(0~20mA) / 00-10(0~10mA)

Low Output corresponds to Low display value [RALS]

Settable range: -19999~+29999;

Setting the Low Display value versus Low output range (as like as 4mA in 04-20).

High Output corresponds to High display value [RAHS]

Settable range: -19999~+29999;

Setting the High Display value versus High output range (as like as 20mA in 04-20)

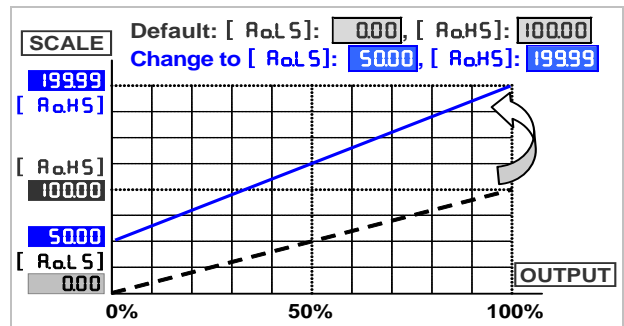

*The interval between [RAHS] and [RALS] should be with minimum over 20% of span; otherwise, it will reflect the less resolution of analogue output.

Fine Zero & Span Adjustment for Analogue Output

Users can get Fine Adjustment of analogue output by front key on the meter. Please connect standard meter to the terminals of analogue output for measuring the output value. To press the front key(up or down key) of meter for adjusting and checking the output.

Fine Zero Adjustment for Analogue Output [RAZRO]: Settable range: -38011~27524;

Fine Span Adjustment for Analogue Output [RASPN]: Settable range: -38011~27524;

High Limited for Analog Output [RALNT] Settable range: 0.00~110.00% of High output;

User can set the output in high limit to avoid destroying the receiver or protection system.

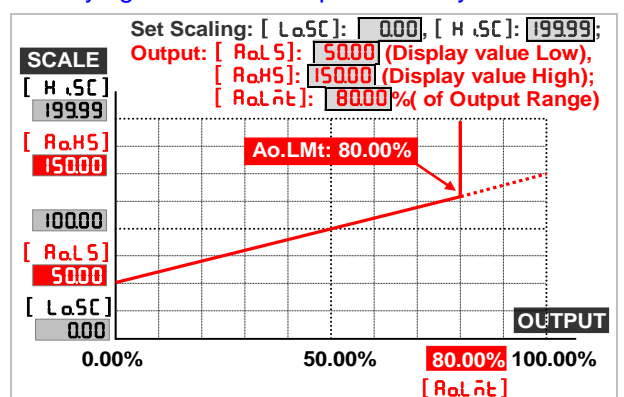

■ RS 485 Communication

CS2 series can be used as Remote Terminal Unit (RTU) for monitoring and controlling in a SCADA (Supervisor Control And Data Acquisition) system. It's not only can be read the measured value and DI (external control inputs) status but also controls the relays output (DO) by RS485 communication ports.

- **Protocol:** Modbus RTU Mode
- **Baud Rate [bAud]:**
Programmable 1200/2400/4800/ 9600/ 19200/ 38400
- **Data Bits:** 8 bits
- **Stop Bits:** Programmable 1 bit or 2 bits
- **Parity [Pr tY]:** Programmable Even / Odd / None
- **Device Number [AdrES]:** Settable 1~255

■ Remote Display function [r5485]

CS2 series has been built-in an innovation function called remote display function.

In past, The meter only receive 4~20mA or 0~10V from AO card or BCD card of PLC. We support a new solution by RS485 for replacing the PLC's AO or BCD cards which it can save costs of AO and wiring to PLC.

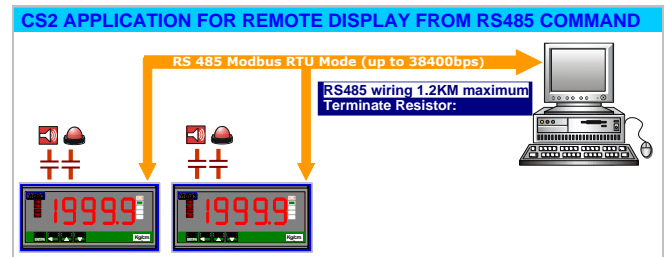

The data(number) will be same as PV that will compare with set-point, analogue output and ECI functions so the data could control analogue output, relay energized and so on.

■ Field Calibration (for CS2-SG / CS2-PM / CS2-RS)

In pass time, the engineers have to take a lot of time to adjust and calibrate meters or converters which the purpose of co-coordinating with zero and span of machinery structure for the Load Cell or Potentiometer measuring. Now, our CS2-SG, CS2-PM and CS2-RS with innovation functions against above to make the engineer operated easily and smoothly that it's called "Field Calibration". The procedures are described as below;

- Enter the right pass code [F.CodE] and access to the Field Calibration Level.
- Adjust the structures of machinery or & equipments to be "lower status".
- The low calibration of machinery structure is not need the exactly "zero" to calibrate, because of the "field calibration" function could be calibrate any lower point.
- Move next page to the [CALLo] and waiting for the value till stable, then pressed **FN ENT** Key to read the signal low of sensing device.
- Waiting for above reading stable (around 3~5seconds), press **FN ENT** Key again to complete the calibration lower point, and go to [CALL5].
- [CALL5] is the page of low scale setting that is relative to the calibration low point.
- Press **✓** Key to next function index [CALH i].
- Adjust the structures of machinery or & equipments to be "higher status".
- The high calibration of machinery structure is not need the exactly "span" to calibrate because of the "field calibration" function could be calibrating any higher point.
- In [CALH i] page, waiting for the value till stable, then pressed **FN ENT** Key to to read the signal high of sensing device.
- Waiting for above reading stable (around 3~5seconds), Press **FN ENT** Key again to complete the calibration higher point, and go to [CALH5].
- [CALH5] is the page of high scale setting that is relative to the calibration high point.
- Press **✓** Key to next functions [CSEL] to select **F.ELd**.
- [CSEL](Calibration parameter selection): Field calibration wouldn't change the default calibration. After user completing the field calibration, it can also select default calibration if the user wants.
 - ▶ As the user finished the procedures of field calibration, the field calibration datum has been saved in EEPROM and it can't change the default(factory) calibration datum. Even the field calibration has been done, the user can still select either default calibration or field calibration.
 - ▶ If the user select field calibration, the [Lo5C](step A-4) and [H.5C](A-5) will be replaced by [CALL5] and [CALH5] which it can not to be changed by anyone. If user has to change the scaling, it's the only way to access field calibration level to set in [CALL5](step F-2) and [CALH5](step F-4).
 - ▶ After selecting the **DEFLE** or **F.ELd**, please double check the [Lo5C](step A-4) and [H.5C](A-5) whether are corrected or not?

Please according to the numbers to do the field calibration (1⇒2⇒3⇒4⇒5⇒6)

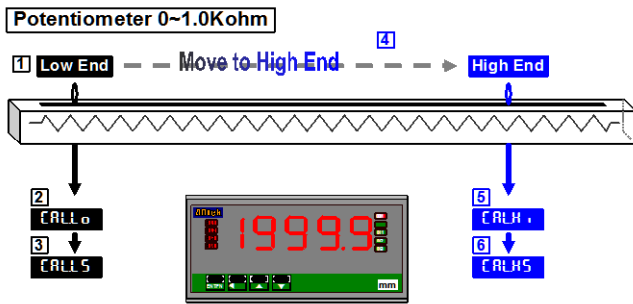

Please according to the numbers to do the field calibration (1⇒2⇒3⇒4⇒5⇒6)

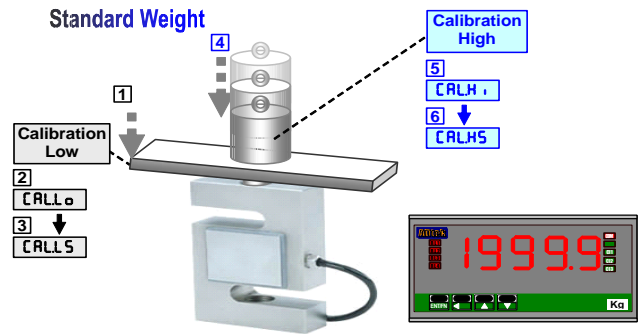

Bank Function(Suffix-3BK) for CS2-VA, CS2-RS

- The function is for CS2-VA and CS2-RS for controlling difference process with a same meter.
- For example; a pressure testing equipment; it has to measure multi-range with difference pressure transducers. The meter can be pre-set 4 groups parameters to show difference scales and relay energized with difference set-points. The operator just selects the bank number (bank1) to meet the process (product A). To make easier operating and to avoid making mistake in process operating.
- 4 banks pre-set for all relay functions are correspondence to 4 difference scaling, decimal point, above select by 3 External Control Inputs(E.C.I.) or front key.
- Example: Current testing

Product A: Current rated: 5A; NG: over 5A

Product B: Current rated: 100A; NG: over 100A

Setting: **BANK1**: [dP]: 0000 [LoSC]: 0000 [H ,SC]: 5.000
 [r-y tnd]: H, [r-y ISP]: 5.000 [r-y trd]: 0.005
BANK2: [dP]: 000 [LoSC]: 000 [H ,SC]: 100.000
 [r-y tnd]: H, [r-y ISP]: 100.000 [r-y trd]: 00.10

[EC ,1]: BANK1 [EC ,2]: BANK2; connect a selector (or DO of PLC) to ECI1 and ECI2 terminals

- The order want to produce Product A must switch selector to A(Label A on panel), and ECI.1 close that the square green LED bright to express the meter will work as per bank1 set. When PV is over 5.000A that relay1 will be energized.
- The second order want to produce Product B must selector to B(Label B on panel), and ECI.2 close that the square green LED bright to express the meter will work as per bank2 set. When PV is over 100.00A that relay1 will be energized..
- Only 1 Bank can be selected, if it is double selection. The priority is Bank1 > Bank2 > Bank3 in order,

ORDERING INFORMATION

CS2-VA - DC/AC/ TRMS Input Signal - Relay Output (OPTION 1) - Analogue Output (OPTION 2) - RS 485 Port (OPTION 3) - Aux. Powered - *Optional Functions. Customize function is welcome. Please contact with our sales window for detail.

CODE	VOLT INPUT	CODE	CURRENT INPUT	CODE	RELAY O/P	CODE	ANALOG O/P	CODE	RS485 PORT	CODE	AXU. POWER
D	DC measuring	D	DC measuring	N	None	N	None	N	None	A	AC 115/230 V
A	AC measuring	A	AC measuring	R2	2 Relay	V	0(1) ~ 5 V 0 ~ 10 V	8	RS 485	OPTION 4	
T	TRMS measuring	T	TRMS measuring	R4	4 Relay	I	0 ~ 10mA 0(4)~20 mA			ADH*	AC/DC 85-264V
V1	0 ~ 199.99 mV	A1	0 ~ 199.99 μ A							ADL*	AC/DC 20-56V
V2	0 ~ 1.9999 V	A2	0 ~ 1.9999 mA								
V3	0 ~ 19.999 V	A3	0 ~ 19.999 mA								
V4	0 ~ 199.99 V	A4	0 ~ 199.99 mA								
V5	0 ~ 300.0 V	A5	0 ~ 1.9999 A								
V6	0 ~ 600 V	A6	0 ~ 1.0000 A								
VA	0 ~ 50 mV	A7	0 ~ 5.000 A								
VB	0 ~ 60 mV	A8	0 ~ 10.000 A								
VC	0 ~ 100 mV	AO	Specify A input								
VO	Specify V input										

* It means RoHS version.

CODE	OPTIONAL
3BK	3 Banks

Excitation Supply DC24V in build for 2 wire transmitters

CS2-PR - Input Signal - Relay Output (OPTION 1) - Analogue Output (OPTION 2) - RS 485 Port (OPTION 3) - Aux. Powered - *Optional Function. Customize function is welcome. Please contact with our sales window for detail.

CODE	INPUT RANGE	CODE	RELAY O/P	CODE	ANALOG O/P	CODE	RS485 PORT	CODE	AXU. POWER	CODE	FUNCTION
A1	0(4) ~ 20mA / 0 ~ 10mA	N	None	N	None	N	None	A	AC115/230V	STAR	Sensor Open Protection
V1	0 ~ 10V / 0(1) ~ 5V	R2	2 Relay	V	0(1) ~ 5 V 0 ~ 10 V	8	RS 485	OPTION 4		SOP	
AV	0~10V/0~20mA(all in one)	R4	4 Relay	I	0 ~ 10 mA 4(0)~20 mA			ADH*	AC/DC 85-264V	SQR	Square root function
AO	Specify A input							ADL*	AC/DC 20-56V		
VO	Specify V input										

* It means RoHS version.

CS2-SG - Input Signal - Relay Output (OPTION 1) - Analogue Output (OPTION 2) - RS 485 Port (OPTION 3) - Excitation Supply - Aux. Powered - *Optional Function. Customize function is welcome. Please contact with our sales window for detail.

CODE	I/P RANGE	CODE	I/P RANGE	CODE	RELAY O/P	CODE	ANALOG O/P	CODE	RS485 PORT	CODE	EXCITATION	CODE	AXU. POWER
S1	1.0mV/V	S8	10.0mV/V	N	None	N	None	N	None	E05	DC 5V	A	AC115/230V
S2	2.0mV/V	S9	20.0mV/V	R2	2 Relay	V	0(1) ~ 5 V 0 ~ 10 V	8	RS 485	E10	DC 10V	OPTION 4	
S3	4.0mV/V	SA	40.0mV/V	R4	4 Relay	I	0 ~ 10 mA 4(0)~20 mA			EO	Specify	ADH*	AC/DC 85-264V
SO	Specify											ADL*	AC/DC 20-56V

CODE	OPTION FUNC.
STAR	High Speed Mode
HSM	

* It means RoHS version.

CS2-PM - Input Signal - Relay Output (OPTION 1) - Analogue Output (OPTION 2) - RS 485 Port (OPTION 3) - Aux. Powered - *Optional Function. Customize function is welcome. Please contact with our sales window for detail.

CODE	I/P RANGE	CODE	RELAY O/P	CODE	ANALOG O/P	CODE	RS485 PORT	CODE	AXU. POWER
P1	0 Ω ~ 50.0 Ω / ~ 2.0 K Ω	N	None	N	None	N	None	A	AC115/230V
P2	0 Ω ~ 2.0 K Ω / ~ 100.0 K Ω	R2	2 Relay	V	0(1) ~ 5 V 0 ~ 10 V	8	RS 485	OPTION 4	
PO	Specify input	R4	4 Relay	I	0 ~ 10 mA 4(0)~20 mA			ADH*	AC/DC 85-264V
								ADL*	AC/DC 20-56V

* It means RoHS version.

CS2-RS - Input Signal - Relay Output (OPTION 1) - Analogue Output (OPTION 2) - RS 485 Port (OPTION 3) - Aux. Powered - *Optional Function. Customize function is welcome. Please contact with our sales window for detail.

CODE	INPUT RANGE	CODE	RELAY O/P	CODE	ANALOG O/P	CODE	RS485 PORT	CODE	AXU. POWER	CODE	OPTION FUNCTION
R1	0.00 Ω ~ 200.00 Ω	N	None	N	None	N	None	A	AC115/230V	3BK	3 Banks
R2	0.0 Ω ~ 2000.0 Ω	R2	2 Relay	V	0(1) ~ 5 V 0 ~ 10 V	8	RS 485	OPTION 4			
R3	0.000 Ω ~ 20.000 K Ω	R4	4 Relay	I	0 ~ 10 mA 4(0)~20 mA			ADH*	AC/DC 85-264V		
R4	0.00 Ω ~ 200.00 K Ω							ADL*	AC/DC 20-56V		
RO	Specify										

* It means RoHS version.

CS2-T - Input Signal - Relay Output (OPTION 1) - Analogue Output (OPTION 2) - RS 485 Port (OPTION 3) - Aux. Powered - *Optional Function. Customize function is welcome. Please contact with our sales window for detail.

CODE	INPUT RANGE	CODE	INPUT RANGE	CODE	RELAY O/P	CODE	ANALOG O/P	CODE	RS485 PORT	CODE	AXU. POWER
P1	Pt100 Ω -50.00-199.99 $^{\circ}$ C	K1	Type K 0.0~1200.0 $^{\circ}$ C	N	None	N	None	N	None	A	AC115/230V
P2	Pt100 Ω -150.0-800.0 $^{\circ}$ C	J1	Type J 0.0~750.0 $^{\circ}$ C	R2	2 Relay	V	0(1) ~ 5 V 0 ~ 10 V	8	RS 485	OPTION 4	
		E1	Type E 0.0~1000.0 $^{\circ}$ C	R4	4 Relay	I	0 ~ 10 mA 0(4)~20 mA			ADH*	AC/DC 85-264V
		T1	Type T 0.0~400.0 $^{\circ}$ C							ADL*	AC/DC 20-56V
		R1	T/C type R 400-1600 $^{\circ}$ C								
		S1	T/C type S 400-1600 $^{\circ}$ C								
		B1	T/C type B 400-1800 $^{\circ}$ C								

* It means RoHS version.

INSTALLATION

Please check the specification, wire diagrams and functions on the label of the meter before installation.

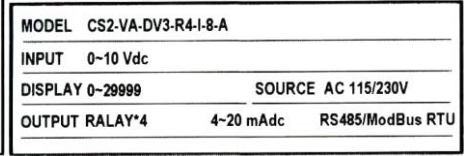
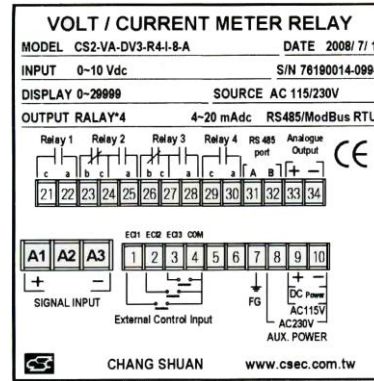

Dimensions & Panel Cut Out

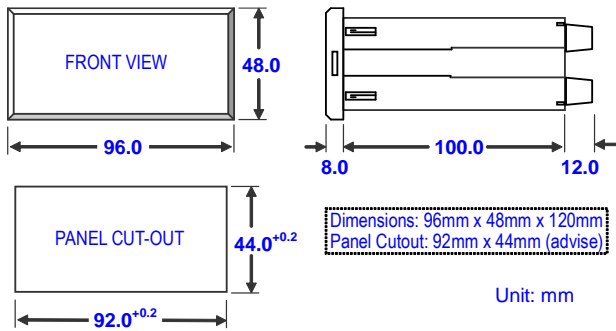

Installation

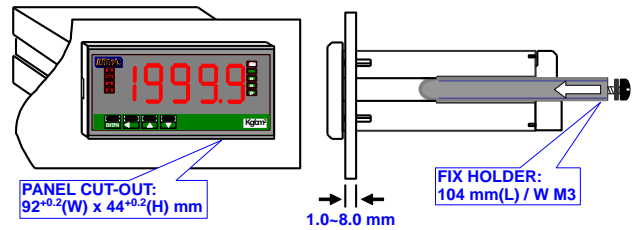

Wiring Diagram

Please check the voltage of power supplied first, and then connect to the specified terminals. Herein, recommended that power supplied with protection by a fuse or circuit breaker to the meter.

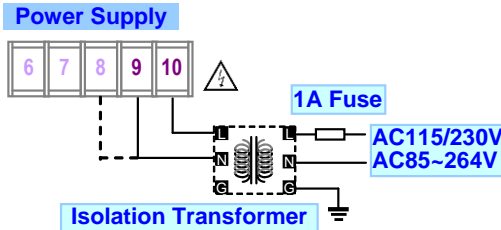

Connector

CS2-VA: #A1~A3(Signal Input): 20A/300Vac, M3.5, 1.3~3.5mm² (22~12AWG); Max torque: 13Kg-cm

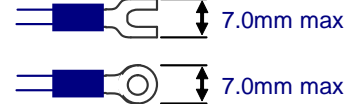

Others: 10A 300Vac, M2.6, 1.3~2.0mm² (22~16AWG), Max torque: 5Kg-cm. Please use cord end terminal.

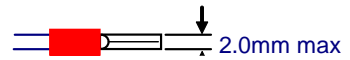

Please set the torque of automotive screwdriver to match the limited of terminals.

For input, RS485 and ECI wiring, Herein recommended using twin wire with shielding.

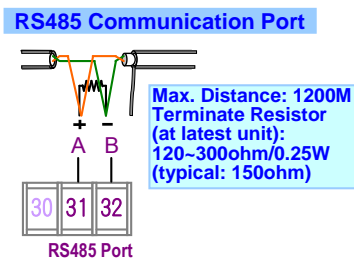

[CS2-VA Voltage / Current Meter Relay]

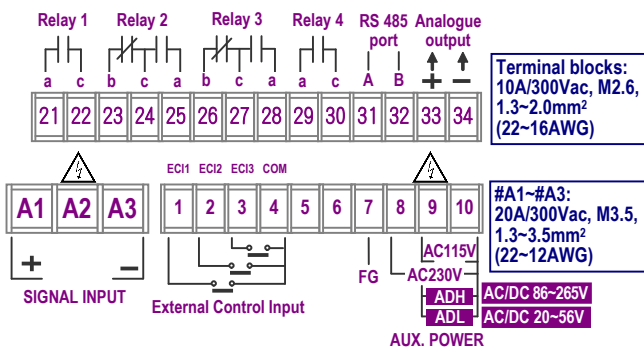

[CS2-RS Resistance Indicator]

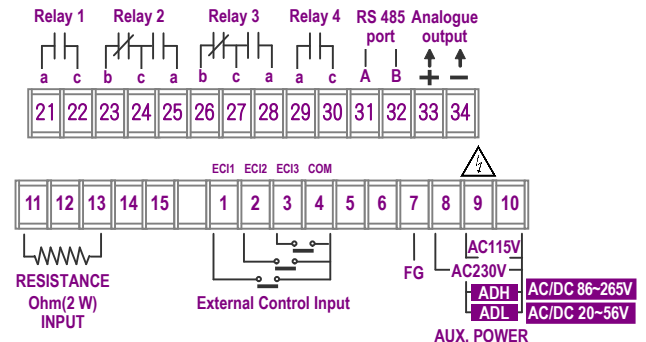

[CS2-PM Potentiometer Indicator]

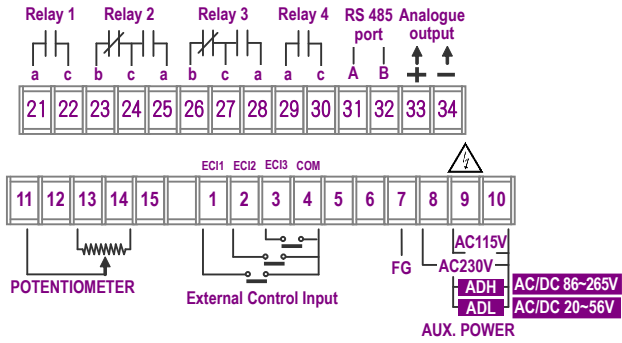

[CS2-T Temperature Indicator]

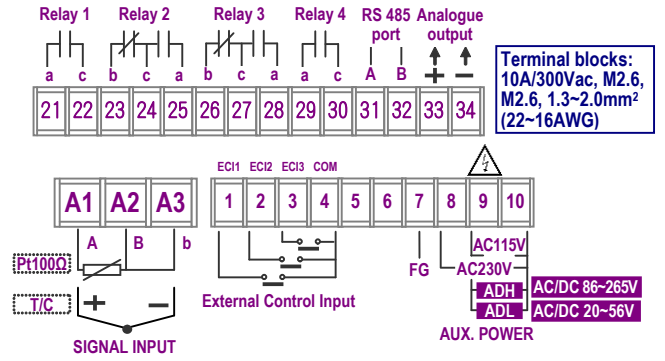

[CS2-PR DC Process (10V/20mA) Indicator]

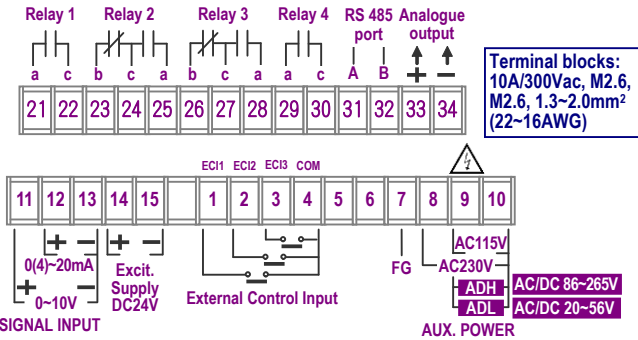

[CS2-SG Strain Gauge / Load Cell Indicator]

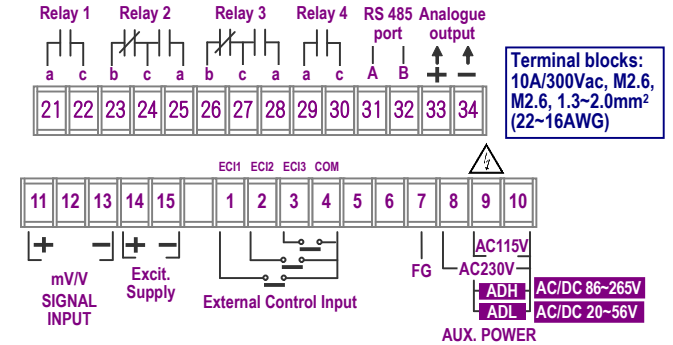

2 wire Transmitter connection

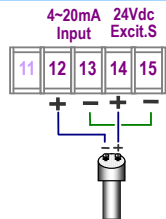

4(0)-20mA Input connection

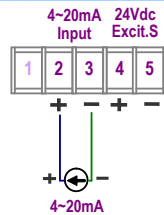

Load Cell connection

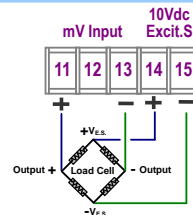

OPERATIONS

Front Panel

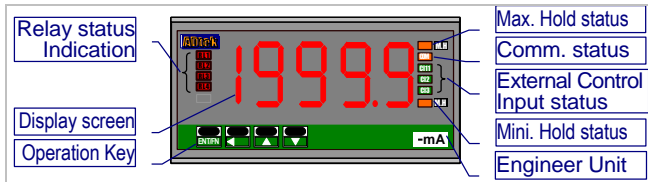

Numeric Screens

0.8”(20.0mm) red high-brightness LED for 4 2/3 digital present values.

I/O Status Indicators

Relay Energized: 4 square red LED

- RL1** display when Relay 1 has been energized;
- RL2** display when Relay 2 has been energized;
- RL3** display when Relay 3 has been energized;
- RL4** display when Relay 4 has been energized;

External Control Input Energized: 3 square green LED

- ECI1** display when E.C.I. 1 has been closed(dry contact)
- ECI2** display when E.C.I. 2 has been closed(dry contact)
- ECI3** display when E.C.I. 3 has been closed(dry contact)

RS485 Communication: 1 square orange LED

COM will flash express the meter is receive or send data, and **COM** flash quickly means the data transient quicker.

Max/Mini Hold indication: 2 square orange LEDs

M.H displayed: To display function expressed it has been selected in Maximum or Minimum Hold function.

Stickers:

Each meter with a sticker to describe what the functions together with engineer label enclosure.

Functions stickers

HH	HI	LO	LL	D.L	D.H	DO	D.H	M.H	Tare
GO	Hi.H	Lo.H	R.PV	R.RS	M.RS	PV.H	BK1	BK2	BK3
DI	RST	DO1	DO2	DO3	DO4	DI1	DI2	DI3	

Relay energized:

- HH** HH Energized **HI** Hi Energized
- Lo** Lo Energized **LL** LL Energized
- GO** Go Energized **Hi.H** Hi Energized & Latch
- DO1** RS485 Energized **Lo.H** Lo Energized & Latch

E.C.I. functions:

- R.PV** Relative PV **Tare** Tare **PV.H** PV Hold
- DI1** Digital Input **BK1** Bank 1 selected
- M.RS** Maximum or Minimum Reset
- R.RS** Reset for Relay Latch

Engineer Label: over 80 types.

~μA	~mA	~A	~KA	=μA	=mA	=A	=KA		
~μV	~mV	~V	~KV	=μV	=mV	=V	=KV		
A hr	A min	A sec	A rms	V rms	A/mA	W/A	Var/A		
W	KW	MW	WH	KWH	MWH	W/WH	W/Var		
Var	KVar	MVar	QH	KQH	MQH	COSθ	Var/VarH		
VA	KVA	MVA	VAH	KVAH	MVAH	θ	KVarH		
Hz	PF	KA	KV	KHz	MVarH	KM/hr			
A	mA	V	mV	Ω	KΩ	°C	°F	%RH	
RPM	M/min	Y/min	F/min	M/sec	%	MΩ			
Kg/cm²	Bar	mmH ₂ O	mmHg	KPA	mmAq	PSI	mBar	PA	
M³/min	ml/min	Ton/D	L/min	Torr	M³/hr	Kg-cm	cmHg		
mm	cm	M	KM	ft	Yard	ppm	ppb	C.C	
g	KG	Ton	T-cm	NT-cm	PH	MPM	L		

Operating Key: 4 keys for Enter(Function) / Shift(Escape) / Up key / Down key. Please refer to detail description in next page.

Pass Code: Settable range:0000~9999;

User must key-in the exactly pass code for access to [Programming Level]. Otherwise, the meter will return to measuring page. If user forgets the pass code, please contact with your service window.

Function Lock: There are 4 levels programmable.

- **None**(**nonE**): no lock at all. User can access to all level for checking and setting.
- **User Level**(**USEr**): User Level lock. User can access to User Level for checking, but can not setting.
- **Programming Level**(**EnG**): Programming level lock. User can access to programming level for checking, but can not setting.
- **ALL**(**RLL**): All lock. User can access to all level for checking but can not setting.

Front Key Function [E.1=UP] & [E.2=dn]

- The Key can be set to be the same function as the setting of [E.1] (**ECI**).
Ex. The [E.1] set to be **Pu.Hld** and the function [E.1=UP] set to be **YES** in [E.1 GROUP]. When user presses Key, the PV will hold as like as terminals of ECI1 close.
- The Key can be set to be the same function as the setting of [E.2].
Ex. The [E.2] set to be **REL.Pu** and the function [E.2=dn] set to be **YES** in [E.1 GROUP]. When user presses Key, the PV will show relative value as like as terminals of ECI2 close.

If the front key function has been set, the terminal input for ECI will be disabling.

■ Error Message

BEFORE POWER ON, PLEASE CHECK THE SPECIFICATION AND CONNECTION AGAIN.

SELF-DIAGNOSIS AND ERROR CODE:

DISPLAY	DESCRIPTION	REMARK
ouFL	Display is positive-overflow (Signal is over display range)	(Please check the input signal)
-ouFL	Display is negative-overflow (Signal is under display range)	(Please check the input signal)
ouFL	ADC is positive-overflow (Signal is higher than input 120%)	(Please check the input signal)
-ouFL	ADC is negative-overflow (Signal is lower than input -120%)	(Please check the input signal)
EEP → FA iL	EEPROM occurs error	(Please send back to manufactory for repaired)
A i.C.nG ← Pu	Didn't execute the calibrate of Input Signal	(Please process Calibrating Input Signal)
A i.C ← FA iL	Input signal calibrated error	(Please check Calibrating Input Signal)
AoC.nG ← Pu	Didn't execute the calibrate of output Signal	(Please process Calibrating Output Signal)
AoC ← FA iL	Output Signal calibrated error	(Please check Calibrating Output Signal)

■ Operating Key:

*Please access to the Programming Level to check and set the parameters when users start to run the meter

- Operating Key: 4 keys for Enter(Function) / Shift(Escape) / Up key / Down key
- The meter has designed operation similar as PC's and . In any page, press key means "enter" or "confirm setting", and press key means "escape ()" or "shift".
- In Programming Level, the screen will return to Measuring Page after do not press any key over 2 minutes, or press for 1 second.

	Function Index	Setting Status
(=) Enter/Fun key	(1) In any page, press to access the level or function index (2) From the function index to access setting status	(3) Setting Confirmed, save to EEPROM and go to next function index
(=) Shift key	(1) In measuring page, press for 1 second to access user level. (2) In function index, press for 1 second to go back upper level. (3) In function group index, press for 1 second to go back measuring page	(4) In setting status, press to Shift the setting position. (5) In setting status, press for 1 second to abort setting and go back this function index.
(=) Up key	(1) In function index, press to go back to previous function index	(2) In setting status for function, press to select function (3) During number Setting, press can roll the digit up
(=) Down key	(1) In Function Index Page, press will go to the next Function Index Page.	(2) In setting status for function, press to select function (3) During number Setting, press can roll the digit down.

Programming Level

Press for 1 sec. to back Measuring Page

Pass Code
Default: 1000
YES

INPUT GROUP	RELAY GROUP	EXTERNAL CONTROL INPUT (E.C.) GROUP	ANALOGUE OUTPUT GROUP	RS485 GROUP
<p>INPUT GROUP</p> <p>r 4-20 / r 1-5P</p> <p>Group: r 4-20 / r 1-5P</p> <p>Function: The function is for CS2-PR only, it'll be hidden for other models</p> <p>Selection: [u0-10] / [u0-5] / [u1-5] / [R0-20] / [R4-20] / [R0-10]</p> <p>Low: r 1.0</p> <p>High: r 100.00</p> <p>Decimal Point of PV: [0] / [00] / [000] / [0000] / [00000]</p> <p>Low scale of PV: [0] / [19999] → +29999</p> <p>High scale of PV: [19999] / [H15C] / [19999] → +29999</p> <p>Function: The function is for CS2-PR only. Square root function for PV: [no] / [YES]</p>	<p>RELAY GROUP</p> <p>r 45b</p> <p>Group: r 45b</p> <p>Start band for Relay energized: [0] / [0-9999] digits</p> <p>Start delay time for Relay energized: [0.00] / [0.9(m)] / [59.9(s)]</p> <p>Relay 1 energized mode: [oFF] / [Lo] / [Hi]</p> <p>Relay 1 Hysteresis: [0] / [0-5000] counts</p> <p>Relay 1 energized delay time: [0.00] / [0.9(m)] / [59.9(s)]</p> <p>Relay 1 de-energized delay time: [0.00] / [0.9(m)] / [59.9(s)]</p> <p>Relay 2 energized mode: [oFF] / [Lo] / [Hi]</p>	<p>EXTERNAL CONTROL INPUT (E.C.) GROUP</p> <p>r ELPu</p> <p>Group: r ELPu</p> <p>EC 1: External Control Input 1: [nonE] / [FELPu] / [PwHLd] / [r5t] / [r5r5t] / [bRnE1]</p> <p>EC 2: External Control Input 2: [nonE] / [FELPu] / [PwHLd] / [r5t] / [r5r5t] / [bRnE2]</p> <p>EC 3: External Control Input 3: [nonE] / [FELPu] / [PwHLd] / [r5t] / [r5r5t] / [bRnE3]</p> <p>dBnc: Debouncing of external control Input: [5-255(x8ms)]</p> <p>UP Key set to be same function as E.C.I.1: [YES] / [no]</p> <p>Down Key set to be same function as E.C.I.2: [YES] / [no]</p>	<p>ANALOGUE OUTPUT GROUP</p> <p>r 4-20</p> <p>Group: r 4-20</p> <p>Output type and range selection: [u0-10] / [u0-5] / [R4-20] / [R0-20] / [R0-10]</p> <p>Low point relative to lowest of Analogue output: [00] / [R0LS] / [-19999] → +29999</p> <p>High point relative to highest of Analogue output: [19999] / [R0HS] / [-19999] → +29999</p> <p>Fine Zero Adjustment for Analog Low Output: [0] / [R0Pro] / [-38011] → +27524</p> <p>Fine Span Adjustment for Analog High Output: [0] / [R0SPn] / [-38011] → +27524</p> <p>clear fine Zero / Span Adjustment for Analogue output: [none] / [R0Pro] / [R0SPn] / [boEH]</p> <p>Analog Output High Limit: [11000] / [R0Lnt] / [0.00-110.00%]</p>	<p>RS485 GROUP</p> <p>r 5485</p> <p>Group: r 5485</p> <p>Device number of the meter: [1] / [1-255]</p> <p>Baud rate: [9600] / [1200] / [2400] / [4800] / [9600] / [19200] / [38400]</p> <p>Parity: [nStb2] / [oStb1] / [EvE] / [odd] / [EvEn]</p>
A-0	B-1	C-1	D-1	F-1
A-1	B-2	C-2	D-2	F-2
A-2	B-3	C-3	D-3	F-3
A-3	B-4	C-4	D-4	F-4
A-4	B-5	C-5	D-5	F-5
A-5	B-6	C-6	D-6	F-6
A-6	B-7	C-7	D-7	F-7

Next Page

Next Page

A-7	PuPro: Fine Low point Adjustment for PV display -19999~+29999	00 PuPro 0	0 rY2Hy 0~5000counts
A-8	PuSPn: Fine High point Adjustment for PV display -19999~+29999	00 PuSPn 0	rY2rd: Relay 2 energized delay time 0:00.0~9(m):59.9(s)
A-9	PuSLr: Clear Fine Zero / Span Adjustment for PV display none / PuPro / PuSPn / both	none PuSLr 0	rY2Fd: Relay 2 de-energized delay time 0:00.0~9(m):59.9(s)
A-10	dSPly: Display Function for PV screen Pu / h.n.H / nRyH / FS485	Pu dSPly Lo	rY3nd: Relay 3 energized mode off / Lo / H. / onHld / H.vHld / do
A-11	LoCut: Low Cut the PV -19999~+29999	00 LoCut 0	rY3Hy: Relay 3 Hysteresis 0~5000counts
A-12	RuG: Average update for PV 1(None)~99times	5 RuG 0	rY3rd: Relay 3 energized delay time 0:00.0~9(m):59.9(s)
A-13	nRuG: Moving Average update for PV 1(None)~10times	1 nRuG 0	rY3Fd: Relay 3 de-energized delay time 0:00.0~9(m):59.9(s)
A-14	dFilt: Digital filter 0(None)/1~99times	0 dFilt 0	rY4nd: Relay 4 energized mode off / Lo / H. / onHld / H.vHld / do / Co-12 / Co-23
A-15	PCode: Pass Code setting for access to Programming Level 0000~9999	0000 PCode none	rY4Hy: Relay 4 Hysteresis 0~5000counts
A-16	FLoLk: Function Level Lock none / USEr / Eng / ALL	none FLoLk 0	rY4rd: Relay 4 energized delay time 0:00.0~9(m):59.9(s)
B-8		0 rY2Hy 0~5000counts	rY4Hy: Relay 4 Hysteresis 0~5000counts
B-9		0000 rY2rd 0:00.0~9(m):59.9(s)	rY4rd: Relay 4 energized delay time 0:00.0~9(m):59.9(s)
B-10		0000 rY2Fd 0:00.0~9(m):59.9(s)	rY4Fd: Relay 4 de-energized delay time 0:00.0~9(m):59.9(s)
B-11		Lo rY3nd off / Lo / H. / onHld / H.vHld / do	
B-12		0 rY3Hy 0~5000counts	
B-13		0000 rY3rd 0:00.0~9(m):59.9(s)	
B-14		0000 rY3Fd 0:00.0~9(m):59.9(s)	
B-15		Lo rY4nd off / Lo / H. / onHld / H.vHld / do / Co-12 / Co-23	
B-16		0 rY4Hy 0~5000counts	
B-17		0000 rY4rd 0:00.0~9(m):59.9(s)	
B-18		0000 rY4Fd 0:00.0~9(m):59.9(s)	

FIELD CALIBRATION (The function is only for CS2-SG / CS2-PM / CS2-RS)

MEASURING PAGE

16888

ENT

Enter the password to
access Programming
Level

PCode

Enter

8

Enter the password to
access Field Calibration
Level

Enter

FCode

YES Press ENT →

Pass Code

default=2000

NO

88888

CALLo

↕

Adjust the structure to be a lower signal output status (or any lower status) and keep it in stable.

CALLo : Field Calibration Low

- Press **ENT** to read signal of the lower status.
- Press **ENT** again to finish the calibration lower point, and go to next page.

88888

CALLS

↕

CALLS : the value to be set is relative to Field Calibration lower point

- Press **ENT** to set the value of lower scale

88888

CALLH

↕

Adjust the structure to be a higher signal output status (or any higher status) and keep it in stable.

CALLH : Field Calibration High

- Press **ENT** to read signal of the higher status
- Press **ENT** again to finish the calibration higher point, and go to next page.

88888

CALLHS

↕

CALLHS : the value to be set is relative to Field Calibration higher point

- Press **ENT** to set the value of Higher scale

DEFLE

↕

CSEL : Calibration parameter selection

- Press **ENT** to access the function and stand by selection
- Press **↕** or **↕** to select (default: DEFLE);

Settable: DEFLE / FELD

DEFLE (default calibration) FELD (Field calibration)

Once the user select field calibration, the [L.o5C] (step A-4) and [H.o5C] (A-5) will be instead of [CALLS] and [CALLH], and can not to be change. If user has to change the scaling, it's the only way to access field calibration level to set in [CALLS] (step F-2) and [CALLH] (step F-4).

Please double check the [L.o5C] (step A-4) and [H.o5C] (A-5) are correct after selection the DEFLE or FELD

■ Operating Steps:

■ User Level

INDEX	FUNCTION DESCRIPTION	PARAMETERS & SETTING	SET
POWER ON		Please check the specification and wiring diagrams firstly.	
88888	Self-diagnosis (LED All bright)		
↓			
[52Pr	Model		
↓			
uEr2.0	Firmware version		
↓			
16888	Measuring Page		
Press for 1 second return to Measuring Page			
0-0-1	 This page will be shown out when [d5PLy](step A-9) function has not set to be Pu. Pu(Pv): Present Value;		
0-1	 rY1SP(rY1.SP):Relay 1 Set-point Please confirm the energized mode of relay 1 before setting.	Settable range: -19999~+29999 	
0-2	 rY2SP(rY2.SP):Relay 2 Set-point Please confirm the energized mode of relay 2 before setting.	Settable range: -19999~+29999 	
0-3	 rY3SP(rY3.SP):Relay 3 Set-point Please confirm the energized mode of relay 3 before setting.	Settable range: -19999~+29999 	
0-4	 rY4SP(rY4.SP):Relay 4 Set-point Please confirm the energized mode of relay 4 before setting.	Settable range: -19999~+29999 	
0-5	 rY.rSt(rY.rSt): Reset for energizing latch of Relay; If the [rY.nd](step B-3/7/11/15) set to be or , and the present value(PV) reach to the condition of relay energizing that the relay will be energized and latching. At mean time, user can reset the relay latching in here.	Programmable: / YES(Yes): reset the relay latching. no(No): abort to reset the relay latching. ■ Be careful, the relay has been energizing and latching again even user had set here to reset the relay latching.. if the PV still reach to the condition of relay energized,	
NEXT PAGE			

0-6		n in (Min): the Minimum value of PV saving; The meter will save the minimum of PV during power on, until reset in [n.rSt](step 0-8). It will save newest minimum PV after reset.	Review only
0-7		n rSt (Max): the Maximum value of PV saving; The meter will save the maximum of PV during power on, until reset in [n.rSt](step 0-8). It will save newest maximum PV after reset.	Review only
0-8		n.rSt (M.rSt): reset the saved value of Maximum & Minimum; The values of maximum and minimum can be reset in here. It will save newest maximum and minimum after reset.	Programmable: <input type="checkbox"/> YES / <input type="checkbox"/> no YES (Yes): to reset the saved value of maximum and minimum. no (No): abort to reset the saved values of maximum and minimum.
0-9		Model of the meters CS2uR (CS2-VA): Volt/Current CS2Pr (CS2-PR): DC 0~10V / 4~20mA CS2SG (CS2-SG): Strain Gauge / Load Cell CS2Pn (CS2-PM): Potentiometer CS2rS (CS2-RS): Resistance CS2t (CS2-T): Rtd /Thermocouple uEr20 (Ver 2.0): Firmware version	Review only It will be announced in our website www.adtek.com.tw , when it had been versions updated.
0-10		This page will be shown out when Bank function was to specified in order (option suffix-3BK) for CS2-VA and CS2-RS only bAnE (Bank): Bank selection and programming	Programmable: <input type="checkbox"/> bnE-0 / <input type="checkbox"/> bnE-1 / <input type="checkbox"/> bnE-2 / <input type="checkbox"/> bnE-3 ▲Up ▼Down Enter Please refer to the description in Page 8/38.
0-0-1		Return to the first page	
Press for 1 second to back to Measuring Page in any page.			

■ Programming Level

INDEX	FUNCTION DESCRIPTION	PARAMETERS & SETTING	SET
	MEASURING PAGE		
	Enter the pass code to access Programming Level		
	Enter the pass code to access programming level.	If user wants to change the pass code, please go to step A-14 to set. Please remind the new pass code.	
Press for 1 second to back Measuring Page			

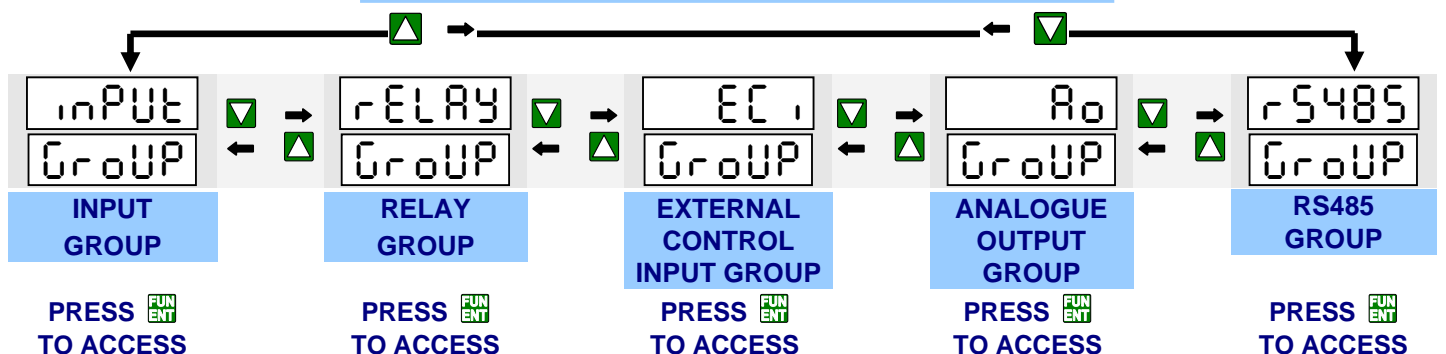

Input Group

INDEX	FUNCTION DESCRIPTION	PARAMETERS & SETTING	SET
<div style="border: 1px solid black; padding: 2px;">inPut</div> <div style="border: 1px solid black; padding: 2px;">GroUP</div> <div style="text-align: center;">FUN ENT ↓</div>	INPUT GROUP INDEX PAGE	In following pages, press for 1 second to back INPUT GROUP INDEX PAGE.	
<div style="border: 1px solid black; padding: 2px;">A.tyP</div> <div style="border: 1px solid black; padding: 2px;">R4-20</div> <div style="border: 1px solid black; padding: 2px;">R4-20</div> <div style="border: 1px solid black; padding: 2px;">0-10</div> <div style="text-align: center;">FUN ENT Nest Page</div>	<p>The function is only for CS2-PR</p> <p>A.tyP (Ai.tyP): Analog input type & range selection</p> <p>There are 3 terminals for mA and V input, if user selects ordering code in input for "AV" from input. Please confirm the wiring is correct or not to set.</p>	<p>Programmable: <u>0-10</u>(0~10V) / <u>0-5</u>(0~5V) / <u>1-5</u>(1~5V) / <u>0-10</u>(0~10mA) / <u>0-20</u>(0~20mA) / <u>R4-20</u>(4~20mA)</p> <p> Up Down Enter</p>	
<div style="border: 1px solid black; padding: 2px;">A.Lo</div> <div style="border: 1px solid black; padding: 2px;">00000</div> <div style="border: 1px solid black; padding: 2px;">000</div> <div style="border: 1px solid black; padding: 2px;">00000</div> <div style="text-align: center;">FUN ENT Nest Page</div>	<p>A.Lo (Ai.Lo): Analogue input low</p> <p>Please refer to the explanations in INPUT & SCALING of FUNCTION DEFINE(page 2/38).</p>	<p>Settable range: 0.00%~100.00%</p> <p> Shift Up Down Enter</p>	
<div style="border: 1px solid black; padding: 2px;">A.Hi</div> <div style="border: 1px solid black; padding: 2px;">10000</div> <div style="border: 1px solid black; padding: 2px;">10000</div> <div style="border: 1px solid black; padding: 2px;">10000</div> <div style="text-align: center;">FUN ENT Nest Page</div>	<p>A.Hi (Ai.Hi): Analogue input high</p> <p>Please refer to the explanations in INPUT & SCALING of FUNCTION DEFINE(page 2/38).</p>	<p>Settable range: 0.00%~100.00%</p> <p> Shift Up Down Enter</p>	
<div style="border: 1px solid black; padding: 2px;">PudP</div> <div style="border: 1px solid black; padding: 2px;">0</div> <div style="border: 1px solid black; padding: 2px;">0</div> <div style="border: 1px solid black; padding: 2px;">00000</div> <div style="text-align: center;">FUN ENT Nest Page</div>	PudP (Pv.dP): Decimal Point of PV	<p>Programmable: <u>0</u> / <u>00</u> / <u>000</u> / <u>0000</u> / <u>0.0000</u></p> <p> Up Down Enter</p>	
<div style="border: 1px solid black; padding: 2px;">Lo.SC</div> <div style="border: 1px solid black; padding: 2px;">00000</div> <div style="border: 1px solid black; padding: 2px;">00</div> <div style="border: 1px solid black; padding: 2px;">00000</div> <div style="text-align: center;">FUN ENT Nest Page</div>	<p>Lo.SC (Lo.SC): Low scale of PV</p> <p>CS2-SG/PM/RS: If the field calibration has been done and then the [CSEL] (Calibration parameter selection) selected to be FELD(field calibration), the [Lo.SC] will be replaced by [CALLS], and it can not be set.</p>	<p>Programmable: -19999~29999</p> <p> Shift Up Down Enter</p>	
<div style="border: 1px solid black; padding: 2px;">Hi.SC</div> <div style="border: 1px solid black; padding: 2px;">19999</div> <div style="border: 1px solid black; padding: 2px;">19999</div> <div style="border: 1px solid black; padding: 2px;">20000</div> <div style="text-align: center;">FUN ENT Nest Page</div>	<p>Hi.SC (Hi.SC): high scale of PV</p> <p>CS2-SG/PM/RS: If the field calibration has been done and then the [CSEL] (Calibration parameter selection) selected to be FELD(field calibration), the [Hi.SC] will be replaced by [CALHS], and it can not be set.</p>	<p>Settable range: -19999~29999</p> <p> Shift Up Down Enter</p>	
<div style="border: 1px solid black; padding: 2px;">Sqr.ot</div> <div style="border: 1px solid black; padding: 2px;">no</div> <div style="border: 1px solid black; padding: 2px;">no</div> <div style="border: 1px solid black; padding: 2px;">YES</div> <div style="text-align: center;">FUN ENT Nest Page</div>	<p>The function is only for CS2-PR</p> <p>Sqr.ot (Square root): Square root function of PV</p> <p>The function used to applicate with differential pressure transducers for flow measuring</p>	<p>Programmable:</p> <p><u>no</u>(No): Do not exclusive square root function.</p> <p><u>YES</u>(Yes): Exclusive square root function.</p> <p> Up Down Enter</p>	A-6
NEXT PAGE			



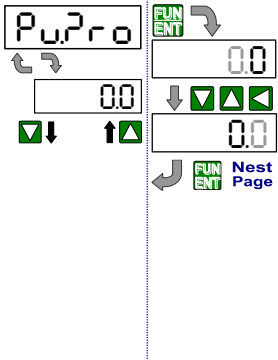
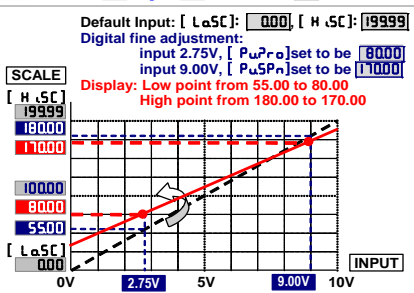
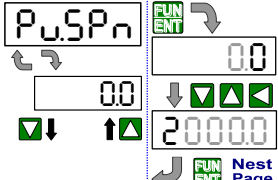
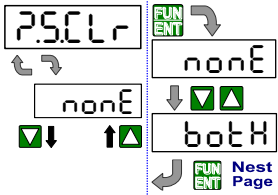
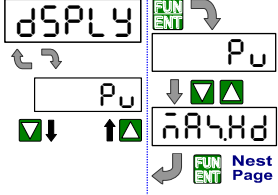
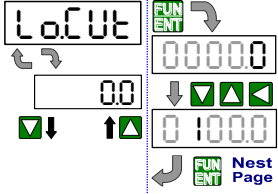
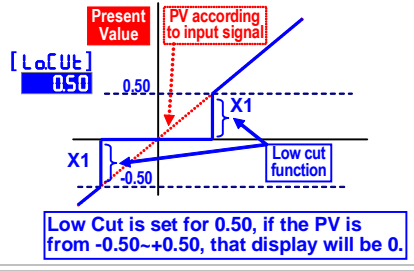
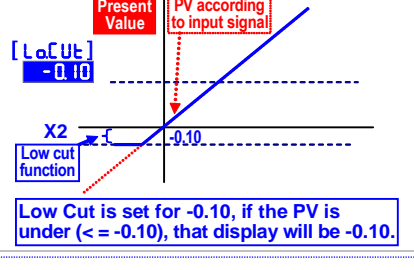

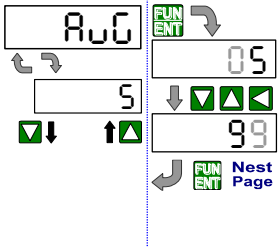
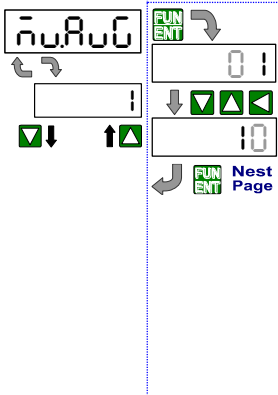
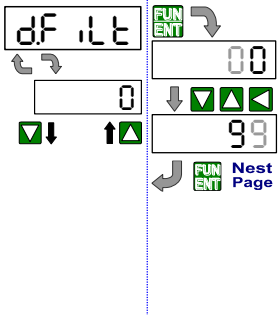
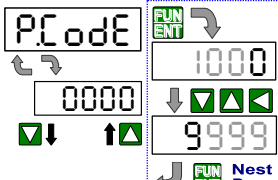
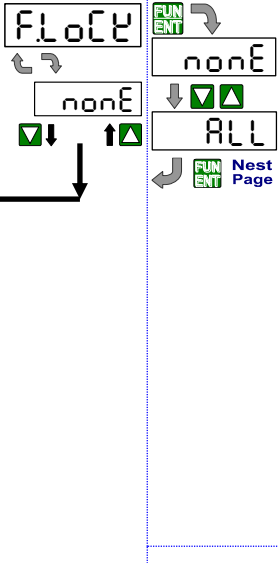
Amend 2009/11/14, Add Square root function





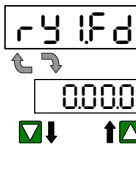
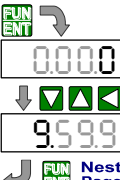
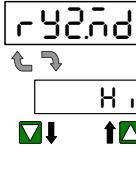

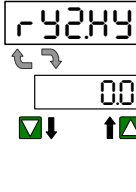
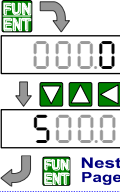
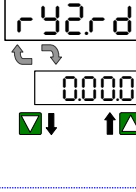
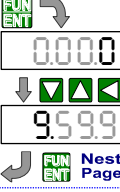
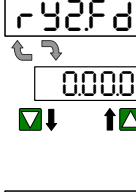
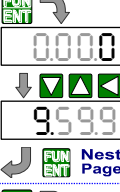
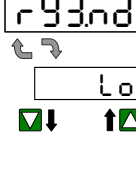

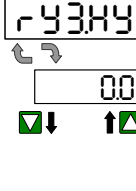
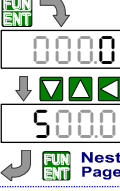
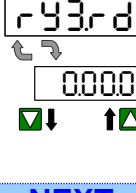
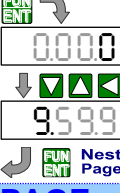
<p>A-7</p> 	<p>Pv.Zro(Pv.Zro): Fine Adjustment low point for PV display;</p> <p>For Zero & Span of PV, users can get the "Fine Adjustment" by front key. It's an easy way to "Just Key-In" the value that the user wants to show in the current input signal. Especially, the [Pv.Zro] & [Pv.SPn] are not only in zero & span of PV, but also any lower point for [Pv.Zro] & higher point for [Pv.SPn]. The meter will be linear for full scale.</p>	<p>Settable range: -19999~+29999</p> <p>◀Shift ▲Up ▼Down ▶Enter</p> 
<p>A-8</p> 	<p>Pv.SPn(Pv.SPn): Fine Adjustment high point for PV display;</p> <p>It's same function as like as [Pv.Zro].</p>	<p>Settable range: -19999~+29999</p> <p>◀Shift ▲Up ▼Down ▶Enter</p>
<p>A-9</p> 	<p>Z.S.CLr (Z.S.CLr): Clear Fine Adjustment of Low / High points for PV display;</p>	<p>Programmable:</p> <ul style="list-style-type: none"> none(None): Do not clear the fine adjustment of Low / High. Pv.Zro(PV.Zro): To clear the fine adjustment Low. Pv.SPn (PV.SPn): To clear the fine adjustment High both(Both): To clear the fine adjustment of Low and High. <p>▲Up ▼Down ▶Enter</p>
<p>A-10</p> 	<p>dSPLY(dSPLY): Display Function for PV screen</p> <p>When the [dSPLY] function set to be RS485, At meantime, the input signal (PV) no longer display now. The PV screen will show the number from RS485 command & data directly. The data(number) will be same as PV that it will compare with set-point, analogue output and ECI functions are correspondent to control analogue output, relay energized and so on.</p>	<p>Programmable:</p> <ul style="list-style-type: none"> Pv(PV): shows PV Min.Hd(MiN.Hd): Minimum Hold of PV Max.Hd(MAX.Hd): Maximum Hold of PV RS485(RS485): Remote displayed from RS485 command of master. <p>▲Up ▼Down ▶Enter</p>
<p>A-11</p> 	<p>Lo.CUt (Lo.CUt): Low Cut the PV</p> <p>if set the positive value (X1) here to display "0" which it expressed to be low-cut the PV between "+X1 (plus)" & "-X1(minus)" /absolute value</p> <p>PV ≤ I Setting value I, the display will be 0.</p> <p>If set the negative value (X2) here to display "X2" which it expressed to be low-cut the PV that it's under the X2 setting value;</p> <p>PV < Setting value, the display will be X2(Setting value).</p>	<p>Settable range: -19999~+29999</p> <p>◀Shift ▲Up ▼Down ▶Enter</p> <p>Low Cut set to be +0.50</p>  <p>Low Cut set to be -0.10</p> 
<p>NEXT PAGE</p>		

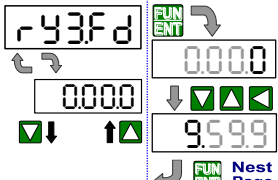
<p>A-12</p> 	<p>AvG(AvG): Average update for PV</p> <p>The meter's sampling is 15cycle/sec If the [AvG](Average) set to be <input type="text" value="3"/> to express the display update with 5 times/sec. The meter will calculate the sampling 1-3 and update the display value. At meantime, the sampling 4-6 will be processed to calculate.</p>	<p>Settable range: 1(no function)~99 times ◀Shift ▲Up ▼Down ▶Enter</p>
<p>A-13</p> 	<p>MAvG(M.AvG): Moving Average update for PV</p> <p>The meter's sampling is 15cycle/sec. If the [MAvG](Moving Average) set to be <input type="text" value="3"/> expressed the display update with 15 times/sec., In the first updated display value will be same as average function. In the next updated display value, the function will get the new fourth sample (sample 4) then throw away the first sample (sample 1) that the newest 3 samples(sample 2,3,4) will be calculated for the updated display value.</p>	<p>Settable range: 0(no function)/1~10 times; ◀Shift ▲Up ▼Down ▶Enter</p>
<p>A-14</p> 	<p>dF iLt(d.FiLt): Digital filter</p> <p>The digital filter can reduce the influence of spark noise by magnetic of coil. If the values of samples are over digital filter band(fixed in firmware and about 5% of stable reading) 3 times (Digital Filter set to be 3) continuously, the meter will admit the samples and update the new reading. Otherwise, it will be as treat as a noise and skip the samples.</p>	<p>Settable range: 0(no function)/1~99 times. ◀Shift ▲Up ▼Down ▶Enter</p>
<p>A-15</p> 	<p>P.CodE(P.CodE): Pass Code setting for access to programming level</p> <p>Please remind and write down the new pass code so that access to programming level.</p>	<p>Settable range: 0000~9999 ◀Shift ▲Up ▼Down ▶Enter</p>
<p>A-16</p> 	<p>FLoCk(F.LoCk): Function level Lock</p> <p>There are 4 levels programmable for lock that the function is to avoid miss-setting.</p>	<p>Programming: <input type="text" value="nonE"/>(None): no lock at all. User can access to user level for checking and setting. <input type="text" value="USEr"/>(User Level): User level lock. User can access to user level for checking, but can not setting. <input type="text" value="EnG"/>(Programming Level): Programming level lock. User can access to programming level for checking, but can not setting. <input type="text" value="ALL"/>(All Level): All lock. User can access to all level for checking, but can not setting. ▲Up ▼Down ▶Enter</p>

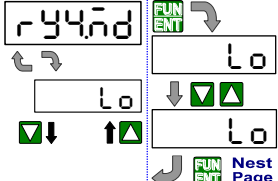
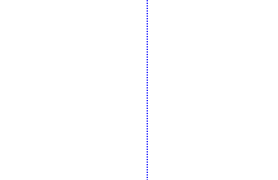
■ Relay Group (The group will not be displayed except the relay function is to be specified)

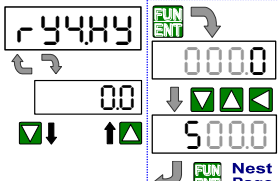
INDEX	FUNCTION DESCRIPTION	PARAMETERS & SETTING	SET
<p>RELAY GROUP</p> <p>↓</p> <p>B-1</p> <p>r45b</p> <p>0000</p> <p>9999</p> <p>Nest Page</p>	<p>RELAY GROUP INDEX PAGE</p> <p>Fig.2</p>	<p>In following pages, press ◀ for 1 second to return the RELAY GROUP INDEX PAGE.</p> <p>Settable range: 0~9999 digits</p> <p>◀Shift ▲Up ▼Down ▶FUN ENT Enter</p>	
<p>B-2</p> <p>r45d</p> <p>0000</p> <p>9599</p> <p>Nest Page</p>	<p>r45d(rY.Sd): start delay time for Relay energized</p>	<p>Settable range: 0:00.0~9(M):59.9(S)</p> <p>◀Shift ▲Up ▼Down ▶FUN ENT Enter</p>	
<p>B-3</p> <p>rY1nd</p> <p>Hi</p> <p>Hi.HLd</p> <p>Nest Page</p>	<p>rY1nd(rY1.Md): Relay 1 energized mode</p> <p>Hi / Lo / Go Relay Energized</p> <p>Relay Energized Latch & Reset</p>	<p>Programmable:</p> <p>oFF(Off): Turn off the Relay and indication LED.</p> <p>Lo(Lo): Low Level Energized; Relay will energize when PV < Set-Point.</p> <p>Hi(Hi): High Level Energized; Relay will energize when PV > Set-Point.</p> <p>Hi.HLd(Hi.HLd)/Lo.HLd(Lo.HLd): High / Low Level energize and latch; As the PV Higher (or lower) than set-point, the relay will be energized to latch except manual reset by from key in [User Level], front key function or terminals of E.C.I. closed</p> <p>do(DO): Digital Output; Relay is energized by RS485 command directly, but no longer to compare with set-point of relay.</p> <p>▲Up ▼Down ▶FUN ENT Enter</p>	
<p>B-4</p> <p>rY1HY</p> <p>0000</p> <p>5000</p> <p>Nest Page</p>	<p>rY1HY(rY1.HY): Relay 1 Hysteresis</p> <p>Energized / De-energized Delay & Hysteresis</p>	<p>Settable range: 0~5000 digits</p> <p>◀Shift ▲Up ▼Down ▶FUN ENT Enter</p>	
<p>B-5</p> <p>rY1rd</p> <p>0000</p> <p>9599</p> <p>Nest Page</p>	<p>rY1rd (rY1.rd): Relay 1 energized delay time</p>	<p>Settable range: 0:00.0~9(M):59.9(S)</p> <p>◀Shift ▲Up ▼Down ▶FUN ENT Enter</p>	
NEXT PAGE			

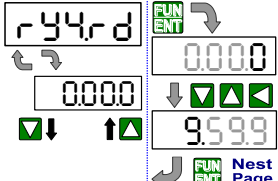
<p>B-6</p> 	<p>rY1Fd (rY1.Fd): Relay 1 de-energized delay time</p> 	<p>Settable range: 0:00.0~9(M):59.9(S) ◀Shift ▲Up ▼Down FUN ENT Enter</p>	
<p>B-7</p> 	<p>rY2Md (rY2.Md): Relay 2 energized mode</p> 	<p>...as same as Relay 1 Energized Mode... Programmable: OFF(off) / Lo(Lo) / H.(Hi) / H.HLd(Hi.HLd) / Lo.HLd(Lo.HLd) / do(DO) ▲Up ▼Down FUN ENT Enter</p>	
<p>B-8</p> 	<p>rY2HY (rY2.HY): Relay 2 Hysteresis</p> 	<p>Settable range: 0~5000 digits ◀Shift ▲Up ▼Down FUN ENT Enter</p>	
<p>B-9</p> 	<p>rY2rd (rY2.rd): Relay 2 energized delay time</p> 	<p>Settable range: 0:00.0~9(M):59.9(S) ◀Shift ▲Up ▼Down FUN ENT Enter</p>	
<p>B-10</p> 	<p>rY2Fd (rY2.Fd): Relay 2 de-energized delay time</p> 	<p>Settable range: 0:00.0~9(M):59.9(S) ◀Shift ▲Up ▼Down FUN ENT Enter</p>	
<p>B-11</p> 	<p>rY3Md (rY3.Md): Relay 3 energized mode</p> 	<p>Programmable: OFF(off) / Lo(Lo) / H.(Hi) / H.HLd(Hi.HLd) / Lo.HLd(Lo.HLd) / do(DO), These functions are same as rY1Md and add Go-12 Go-12(Go-12): This function is programmable in Relay 3 or 4 only. If the Relay 3 or 4 set to be Go-12 functions, the relay will compare with [rY1.SP] and [rY2.SP]. Go relay energized when the condition is [rY1.SP](Hi)>PV>[rY2.SP](Lo) ▲Up ▼Down FUN ENT Enter</p>	
<p>B-12</p> 	<p>rY3HY (rY3.HY): Relay 3 Hysteresis</p> 	<p>Settable range: 0~5000 digits ◀Shift ▲Up ▼Down FUN ENT Enter</p>	
<p>B-13</p> 	<p>rY3rd (rY3.rd): Relay 3 energized delay time</p> 	<p>Settable range: 0:00.0~9(M):59.9(S) ◀Shift ▲Up ▼Down FUN ENT Enter</p>	
<p>NEXT PAGE</p>			

<p>B-14</p> 	<p>rY3Fd (rY3.Fd): Relay 3 de-energized delay time</p>	<p>Settable range: 0:00.0~9(M):59.9(S) ◀Shift ▲Up ▼Down Enter</p>
<p>B-15</p> 	<p>rY4Md (rY4.Md): Relay 4 energized mode</p>	<p>Programmable: OFF(Off) / Lo(Lo) / Hi(Hi) / Hi.HLd(Hi.HLd) / Lo.HLd(Lo.HLd) / do(DO), These function are same as rY1Md and more Go-1.2 / Go-2.3</p>
<p>B-16</p> 	<p>rY4HY (rY4.HY): Relay 4 Hysteresis</p>	<p>Settable range: 0~5000 digits ◀Shift ▲Up ▼Down Enter</p>
<p>B-17</p> 	<p>rY4rd (rY4.rd): Relay 4 energized delay time</p>	<p>Settable range: 0:00.0~9(M):59.9(S) ◀Shift ▲Up ▼Down Enter</p>
<p>B-18</p> 	<p>rY4Fd (rY4.Fd): Relay 4 de-energized delay time</p>	<p>Settable range: 0:00.0~9(M):59.9(S) ◀Shift ▲Up ▼Down Enter</p>

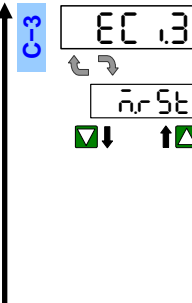
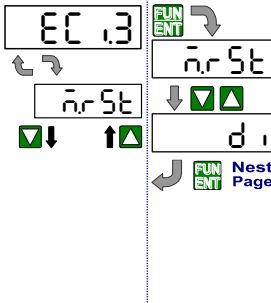
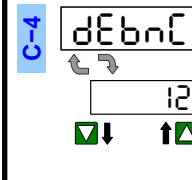
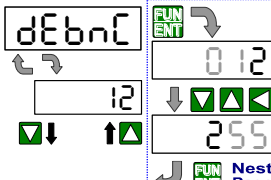
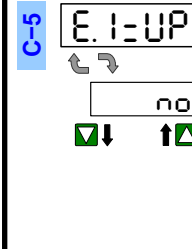
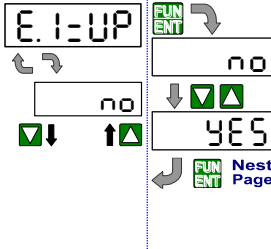
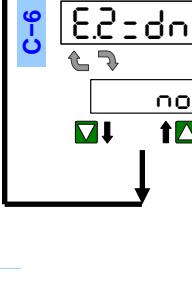
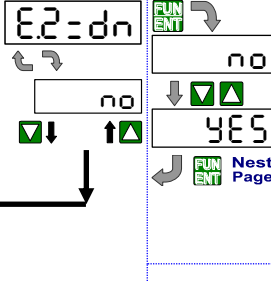
<p>C-3</p> 		<p>EC 3 (ECi.3): External Control Input 3</p>	<p>Programmable: <input type="checkbox"/> nonE / <input type="checkbox"/> F.E.L.P.u / <input type="checkbox"/> P.u.H.L.d / <input type="checkbox"/> n.r.S.t <input type="checkbox"/> / <input type="checkbox"/> F.y.r.S.t / <input type="checkbox"/> d.i, These functions are same as EC 1.1 and more b.A.n.E.3</p> <p>Optional function for CS2-VARS b.A.n.E.3 (Bank 3): as same function as b.A.n.E.1 (Bank 1)</p> <p>▲Up ▼Down Enter</p>
<p>C-4</p> 		<p>dEbnc (dEbnc): Debouncing of external control Input</p>	<p>Settable range: 5~255 (x 8ms)</p> <p>◀Shift ▲Up ▼Down Enter</p>
<p>C-5</p> 		<p>E.1=UP (E.1=UP): The ▲Up Key can be set to be the same function as the setting for [EC 1.1].</p> <p>Ex. The [EC 1.1] set to be P.u.H.L.d (Pv.HLd) and the function [E.1=UP] set to be YES simultaneously. The user presses ▲Up Key to replace the manual ECI 1 terminal closed,</p>	<p>Programmable: <input type="checkbox"/> YES (YES): Up Key is to be same function as ECI1 <input type="checkbox"/> no (NO) : Up Key isn't to be same function as ECI1</p> <p>▲Up ▼Down Enter</p>
<p>C-6</p> 		<p>E2=dn (E.2=DN): The ▼Down Key can be set to be the same function as the setting for [EC 1.2].</p> <p>Ex. The [EC 1.2] set to be P.u.H.L.d (Pv.HLd) and the function [E.2=dn] set to be YES simultaneously. The user presses ▼Down Key to replace the manual ECI 2 terminal closed,</p>	<p>Programmable: <input type="checkbox"/> YES (YES): Down Key is to be same function as ECI2. <input type="checkbox"/> no (NO): Down Key isn't to be same function as ECI2.</p> <p>▲Up ▼Down Enter</p>

■ Analogue Output Group (The group will not be displayed except the AO function is to be specified)

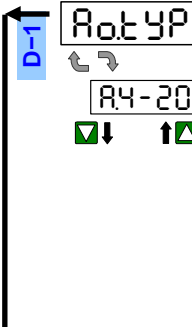
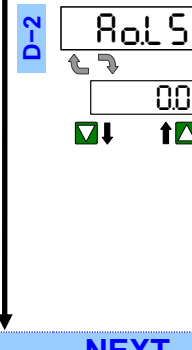
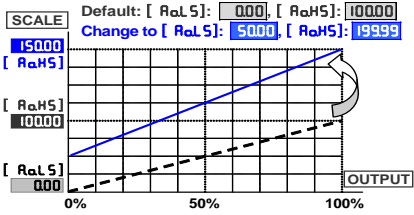
INDEX	FUNCTION DESCRIPTION	PARAMETERS & SETTING	SET
<p>Ao GROUP</p>	<p>AO GROUP INDEX PAGE</p>	<p>In following pages, press ◀ for 1 second to return the AO GROUP INDEX PAGE.</p>	
<p>D-1</p> 	<p>Ao.tYP (Ao.tYP): Analogue Output type and range selection;</p> <p>Analogue output type had been fixed in mA or V as customer ordering requested. Therefore, the type selection is only for the ranges in same type (Voltage or Current).</p>	<p>Programmable:</p> <p>Voltage Output: <input type="checkbox"/> 0-10 (0~10V) / <input type="checkbox"/> 0-5 (0~5V) / <input type="checkbox"/> 1-5 (1~5V)</p> <p>Current Output: <input type="checkbox"/> 0-10 (0~10mA) / <input type="checkbox"/> 0-20 (0~20mA) / <input type="checkbox"/> 4-20 (4~20mA)</p> <p>▲Up ▼Down Enter</p>	
<p>D-2</p> 	<p>Ao.LS (Ao.LS): the Low point is relative to Analogue Output low;</p> <p>To set the lower display value versus low output range (as like as 4mA in R4-20) Ex. Output range set to be R4-20 (4~20mA) is relative to display 0~199.99. User can set the [Ao.LS] (Ao.LS) to be 50.00. At meantime, the output signal will be 4mA when the present value is 50.00.</p>	<p>Settable range: -19999~29999</p> <p>◀Shift ▲Up ▼Down Enter</p>  <p>Default: [Ao.LS]: 000, [Ao.HS]: 10000 Change to [Ao.LS]: 5000, [Ao.HS]: 10000</p>	
<p>NEXT PAGE</p>			

D-3		<p>R_oHS (Ao.HS): the High point is relative to Analogue Output high;</p> <p>To set the higher display value versus high output range (as like as 20mA in R₄-20) Ex. Output range set to be R₄-20 (4~20mA) is relative to display 0~199.99. User can set the [R_oHS] (Ao.HS) to be 15000. At meantime, the output signal will be 20mA when the present value(PV) is 150.00.</p>	<p>Settable range: -19999~29999</p> <p>◀Shift ▲Up ▼Down Enter</p>
D-4		<p>R_oZro (Ao.Zro): Fine Zero Adjustment for Analog Low Output;</p> <p>Users can get Fine zero Adjustment for analogue output by front key. Please connect standard meter to the terminal of analogue output for measuring the output value. To press the front key(up or down key) to adjust and check the output of meter.</p>	<p>Settable range: -38011~27524</p> <p>◀Shift ▲Up ▼Down Enter</p>
D-5		<p>R_oSPn (Ao.SPn): Fine Span Adjustment for Analog high Output;</p> <p>Users can get Fine span Adjustment for analogue output by front key of the meter as like as [R_oZro] (Ao.Zro).</p>	<p>Settable range: -38011~27524</p> <p>◀Shift ▲Up ▼Down Enter</p>
D-6		<p>Z.S.Clr (Z.S.Clr): Clear the Fine Zero / Span Adjustment for Analog Output</p>	<p>Programmable:</p> <p>none(None): Do not clear</p> <p>R_oZro(Ao.Zro): Clear low adjust</p> <p>R_oSPn(Ao.SPn): Clear high adjust</p> <p>both(both): Clear low & high adjust</p> <p>▲Up ▼Down Enter</p>
D-7		<p>R_oLMt (Ao.LMt): Analog Output High Limit</p>	<p>Settable range: 0.00~ 110.00% of FS</p> <p>◀Shift ▲Up ▼Down Enter</p>

■ RS485 Group (The group will be hidden, if the relay function is not to be specify)

INDEX	FUNCTION DESCRIPTION	PARAMETERS & SETTING	SET	
r5485 GROUP 	RS485 GROUP INDEX PAGE	In following pages, press ◀ for 1 second to return the RS485 GROUP INDEX PAGE.		
E-1	AdRES 001 255 	<p>AdRES (Address): Device number of the meter.</p>	<p>Settable range: 1~255</p> <p>◀Shift ▲Up ▼Down Enter</p>	
E-2	bRUd 9600 38400 	<p>bRUd (bAUd): Baud rate</p>	<p>Programmable:</p> <p>1200 / 2400 / 4800 / 9600 / 19200 / 38400</p> <p>▲Up ▼Down Enter</p>	
NEXT	PAGE			

E-3

Pr.tY (PritY): Parity

Programmable:

- nStb.1 (n.Stb.1): None, 1 stop bit
- nStb.2 (n.Stb.2): None, 2 stop bit
- odd (odd): odd
- EuEn (Even): Even

▲Up ▼Down **FUN ENT** Enter

Field Calibration Group [for CS2-SG / CS2-PM / CS2-RS only]

Please according to the numbers to do the field calibration (1⇒2⇒3⇒4⇒5⇒6)

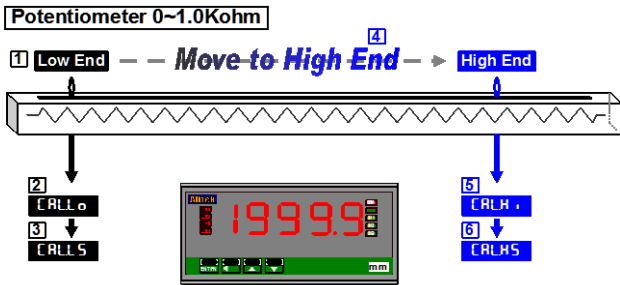

Please according to the numbers to do the field calibration (1⇒2⇒3⇒4⇒5⇒6)

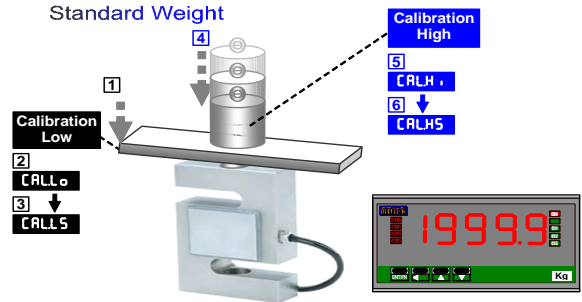



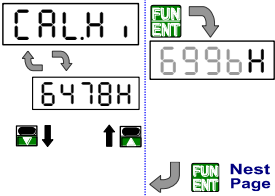
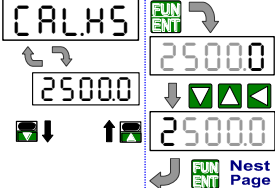
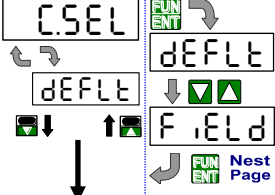











INDEX	FUNCTION DESCRIPTION	PARAMETERS & SETTING	SET
16888	Measuring Page		
EntEr	Pass Code Page		
P.CodE			
EntEr	Pass Code Page for Field Calibration Level	Enter the exactly pass code of the meter to access the Field Calibration Level. Otherwise, it will be turning back to measuring page.	
F.CodE			
NO	Adjust the structure of machinery to the lower signal output status(or any lower status).		
Pass Code			
YES			
[CALLo]	[CALLo (CAL.Lo): Field Calibration Low. The low calibration is not need the exactly "zero" to calibrate because of the "field calibration" function could be calibrate any lower point.	<ul style="list-style-type: none"> Waiting for the value till stable, pressed FUN ENT Key to read signal low of sensing device. Waiting for above reading stable (around 3~5seconds), press FUN ENT Key again to complete the calibration lower point, and go to [CALLS]. 	
[CALLS]	[CALLS (CAL.LS): the value to be set is relative to Field Calibration low point.	Settable range: -19999~29999 ◀Shift ▲Up ▼Down FUN ENT Enter	
NEXT PAGE			

<p>F-3</p> 	<p>Adjust the machinery structure to the higher signal output status(or any higher status).</p> <p>[CAL.H](CAL.Hi): Field Calibration High.</p> <p>The high calibration is not need the exactly "span" to calibrate because of the "field calibration" function could be calibrating any higher point.</p>	<ul style="list-style-type: none"> Waiting for the value till stable, pressed [FUN ENT]Key to read signal high of sensing device. Waiting for above reading stable (around 3~5seconds), press [FUN ENT] Key again to complete the calibration higher point, and go to [CAL.H5]. 	
<p>F-4</p> 	<p>[CAL.H5 (CAL.HS): the value to be set is relative to Field Calibration high point.</p>	<p>Settable range: -19999~29999</p> <p>[Shift] [Up] [Down] [FUN ENT]Enter</p>	
<p>F-5</p> 	<p>[C.SEL (C.SEL): Calibration parameter selection;</p> <p>As the user finished the procedures of field calibration, the field calibration datum has been saved in EEPROM and it can't change the default(factory) calibration datum . Even the field calibration has been done, the user can still select either default calibration or field calibration.</p>	<p>Programmable:</p> <p>[DEFLE](default): factory calibration points and factors</p> <p>[F.iELd](field): field calibration points and factors</p> <p>[Up] [Down] [FUN ENT]Enter</p> <ul style="list-style-type: none"> If the user select field calibration of the [LoSC](step A-4) and [H.iSC](A-5) will be replaced by the [CAL.L5] and [CAL.H5] which it can not to be change by anyone. If user has to change the scaling, it's the only way to access field calibration level to set in [CAL.L5](step F-2) and [CAL.H5](step F-4). Please double check the [LoSC](step A-4) and [H.iSC](A-5) whether are correct after selection the [DEFLE] or [F.iELd]. 	
<p>Go back to Measuring Page</p>			

■ TROUBLE SHOOTING

Display Issue:

PROBLEM	CHECKING LIST	REMEDY
Display shows  	1.To inspect whether did the input signal type (V/A/mA..) of meter match with field signal or not?	Please change another meter that is matching in the field. ▶ For CS2-PR, input range can be programmed in same type(mA or V). Please check the [R tYP] in [INPUt GROUP].
	2.To inspect whether the input signal is over +120% (input high limit) or -120% (input low limit)?	A.Please check the [R tLo] and [R tHi] in [INPUt GROUP] are correct or not. B.Please changes another meter that is matching in the field.
	3. To inspect whether did the wires connect correct and secure or not?	A.Please checks carefully the connection diagram of label on the meter. B.Please uses the terminals(Y, Ring or cord end terminal) to avoid the risk of insecure.
Incorrect ion display value or out of accuracy	1. To inspect the input signal type (V/A/mA..) or range of meter whether did match with signal in the field or not?	A.Please check the [R tLo] and [R tHi] in the [INPUt GROUP] whether did the both set correct or not ? Generally, the [R tLo] is  % and [R tHi] is  %, if the input specification of meter is same as range of signal in field. B.Please changes another meter that is matching in field.
	2.To inspect the settings of high and low scale whether did it correct or not?	Please check the [H tSC](A-05) and [LoSC](A-04) in [INPUt GROUP].
	3.To inspect the high and low fine adjustments of PV are changed or not?	Please check the [P uSPn](A-07) and [P uP r o](A-06) in [INPUt GROUP] whether did the values can be cleared in [P5CLr](A-08).
	CS2-Pr: 4.To inspect the input signal range whether did it match with signal in the field or not?	Please check the [R tYP](A-00) that has to match the signal in the field.
	CS2-SG/CS2-PM 5.To inspect the field calibration whether did it match with sensor in the field or not?	Please check the [CLL5](F-02) and [CLH5](F-04) both are matched the measuring range of sensor.
Jittery Display	1.To inspect the input signal is jittery or not?	A.If the input signal is jittery continuously, please set higher value in [R uG](A-11) or [h uR uG](A-12) B.If the input signal is jittery uncertain period that caused by the inductive load actions, please set higher value in [dF tL t](A-13) C.Please does not lay the wires of input together with high-voltage lines or power lines. As a general rule, wire the meter in a separate system, use an independent metal conduit, or use shielded cable.
	2.To inspect the input signal is stable.	A.If the input signal is jittery continuously, please set higher value in [R uG](A-11) or [h uR uG](A-12) B.If the input signal is jittery uncertain period that caused by the inductive load actions, please set higher value in [dF tL t](A-13) C.Please connects an isolation transformer as close as meter in power lines.
Display shows "-----"	To inspect display function [dSPLY]. It's maybe to be set to 	Please check the [dSPLY](A-09) in [INPUt GROUP] and change the function setting from  to  .
display value doesn't change	1.To inspect display function [dSPLY]. It's maybe to be set to  (maximum hold) or  (minimum hold), and the M.H LED is brighten.	Please check the [dSPLY](A-09) in [INPUt GROUP] and change the function set from  or  to  .
	2.To inspect external control input function [EC t]. It's maybe to be set to  , and the relate LED is brighten.	A.Please check the [EC t](C-01/02/03) in [EC t GROUP] and change the function setting from  to  B.ECI function has been energized by terminals close. Please open the terminals.

Relay Output Issue:		
PROBLEM	CHECKING LIST	REMEDY
The parameters of Relay doesn't shown	Check if the label of meter for detail specification.	A.Please check the product number and output(O/P:_____) description again for confirmation the relay output is specified or not? B.Please send back to our sales window, or order another meter with relay function.
Relay cans not action.	The relay energized, but square red LED doesn't bright	
	1.Check the energized mode	Please check the [rY lnd](B-03/07/11/15) in the [RELAY GROUP]
	2.Check the delay time and delay band in the start delay function.	Please check whether the [rYsb] (B-01) did is too wide and [rY5d](B-02) is too long in [RELAY GROUP] or not?
	3. Check the energized delay time	Please check whether did the [rY lnd](B-05/09/13/17) is too long in [RELAY GROUP] or not?
	The relay energized, but square red LED dose bright	
1.Check the wiring of relay output	According to the label of meter, please check again the connection wire of relay. Be careful to check the number of relay is matching the setting.	
2.Check the voltage of supply power		

Analogue Output Issue:		
PROBLEM	CHECKING LIST	REMEDY
Incorrect ion analogue output value or out of accuracy	1. To inspect the output signal type (V/A/mA..) or range of meter whether did match with signal in the field or not?	A.Please check the product number and output(O/P:_____) description again for confirmation the analogue output is specified or not? If it was not specified, please send back to our sales window, or order another product with relay function. B.Please confirm the output type is correct and check the range in [RoltYP](D-01) of [Ro GROUP]
	2. Check the Analogue output high and low setting.	A.Please check the [RoltS](D-02) and [RoltH](D-03) in [Ro GROUP].
Jittery Analogue Output	Analogue output is according to the display	
	1.Check if the display is jittery	A.If the input signal was jittery continuously, please set higher value in [RUG](A-11) or [RUG](A-12) B.If the input signal is jittery with a uncertain period that caused by the inductive load actions, please set higher value in [dF lL](A-13) C.Please does not lay the wires of input together with high-voltage lines or power lines. As a general rule, wire connecting with the meter has to be in a separate system, use an independent metal conduit, or use shielded cable.
	2.Check if the display is stable	Please do not lay the wires of output together with high-voltage lines or power lines. As a general rule, wire connecting with the meter has to be in a separate system, use an independent metal conduit, or use shielded cable.

RS485 Communication Issue:		
PROBLEM	CHECKING LIST	REMEDY
Can not link	Check if the square orange LED of RS485 doesn't bright.	A.Please check the [RdrES](E-01) \ [bRUd](E-02) and [Pr lty](E-03) in [RS485 GROUP] that both have to match the Host. B.Please check the wiring A(+) and B(-) are correct or not? C.If user uses a converter (RS485/RS232 or RS485/USB..), please check the converter of setting and wiring is correct or not? D.Please check the protocol of host is Modbus RTU Mode
Reply wrong data from the meter	1.Check if the square orange LED of RS485 dose bright, but no reply.	A.Please confirms the CHECH SUM program is correct. B.Please check the interval of each command has to over 3.5byte.

<p>2. Check if the square orange LED of RS485 dose bright, but reply Error.</p>	<p>A.Please checks the address table of RS485 to assume whether did the address right or not? B.Please checks the start address and data format are correct. C. Please do not lay the wires of RS485 together with high-voltage lines or power lines. As a general rule, wire the meter in a separate system, use an independent metal conduit, or use shielded cable.</p>
---	---

■ RS485 MODBUS RTU MODE

■ Modbus RTU Mode protocol

1. Function 03H (Read Holding Registers)

Request Data Frame; EX: Read the data of display value(0000H starts from 1 Word)

SLAVE Address	FUNCTION	Starting Address Hi	Starting Address Lo	No. of Word Hi	No. of Word Lo	CRC Lo	CRC Hi
01H	03H	00H	00H	00H	01H	84H	0AH

Response Data Frame; EX: The response value is "0"

SLAVE Address	FUNCTION	Byte count	Data Hi	Data Lo	CRC Lo	CRC Hi
01H	03H	02H	00H	00H	B8H	44H

Request Data Frame (EX: Continue to request the data of 10 points)

SLAVE Address	FUNCTION	Starting Address Hi	Starting Address Lo	No. of Word Hi	No. of Word Lo	CRC Lo	CRC Hi
01H	03H	00H	00H	00H	0AH	C5H	CDH

Response Data Frame

SLAVE Address	FUNCTION	Byte count	Data(1) Hi	Data(1) Lo	Data(10) Hi	Data(10) Lo	CRC Lo	CRC Hi
01H	03H	14H	00H	00H	01H	00H	--	--

2. Writing Command by Function 06H (Preset Single Register)

Request Data Frame

SLAVE Address	FUNCTION Code	Starting Address Hi	Starting Address Lo	Preset DATA Hi	Preset DATA Lo	CRC Lo	CRC Hi
01H	06H	00H	00H	00H	02H	08H	0BH

Response Data Frame

SLAVE Address	FUNCTION Code	Starting Address Hi	Starting Address Lo	Preset DATA Hi	Preset DATA Lo	CRC Lo	CRC Hi
01H	06H	00H	00H	00H	02H	08H	0BH

■ ADDRESS TABLE **Address number are Hexadecimal

■ User level

Name	Address	Range	Explain	Initial	Write/Read	Note
PV	0000h	-19999~29999	Present Value		R	
rY1SP	0001h	-19999~29999	Relay1 Set Point	10000	R/W	
rY2SP	0002h	-19999~29999	Relay2 Set Point	10000	R/W	
rY3SP	0003h	-19999~29999	Relay3 Set Point	10000	R/W	
rY4SP	0004h	-19999~29999	Relay4 Set Point	10000	R/W	
RELAY STATUS	0005h	0~1	RELAY STATUS bit0~bit3:relay1~relay4; 0=Relay off 1=Relay on		R/W	
ECI STATUS	0006h	0~1	ECI STATUS bit0~bit2:ECI.1~ECI.3; 0=untriged 1:triged		R	
PuHLd	0007h	-19999~29999	PV Hold		R	
n in	0008h	-19999~29999	The Minimum of PV	0	R	
nR4	0009h	-19999~29999	The Maximum of PV	0	R	
SYSTEM STATUS	000Ah		SYSTEM STATUS bit0=1 EEP fail; bit1=1 Input calibration fail; bit2=1 Input calibration NG; bit3=1 Analogue Output calibration fail; bit4=1 Analogue Output calibration NG		R	
n r 5t	000Bh	0~1	Reset Maximum & Minimum Value 0:No 1:Yes	0	R/W	
r 5485	000Ch	-19999~29999	PV showing from RS485 command(data)	0.00%	R/W	

■ Programming Level

[Input Group]						
Name	Address	Range	Explain	Initial	Write/Read	Note
RESERVED	000Dh		No use unless CS2-PR	0	R/W	
R i t Y P		0~5	The address is for CS2-PR only Analogue Input Type 0: 0~10V 1: 0~5V 2: 1~5V 3: 0~20mA 4: 4~20mA 5: 0~10mA			
R i L o	000Eh	0.00~100.00%	Input Low	0.00%	R/W	
R i H i	000Fh	0.00~100.00%	Input High	100.0%	R/W	
P u d P	0010h	0~4	PV Decimal Point 0: 00000 1: 0000.0 2: 000.00 3: 00.000 4: 0.0000	0	R/W	
L o S C	0011h	-19999~29999	Low Scale	0	R/W	
H i S C	0012h	-19999~29999	High Scale	19999	R/W	
P u Z e r o	0013h	-19999~29999	PV ZERO	0	R/W	
P u S P a n	0014h	-19999~29999	PV SPAN	0	R/W	
P S r S e t	0015h	0~3	The clear of PV_ZERO and PV_SPAN 0: None 1: PV_ZERO 2: PV_SPAN 3: Both	0	R/W	
d S P L Y	0016h	0~3	Display Mode 0: PV 1: Minimum Hold 2: Maximum Hold 3: RS485	0	R/W	
L o C u t	0017h	-19999~19999	Low Cut	0	R/W	
A v e	0018h	1~99	Average	5	R/W	
d F i l t e r	0019h	0~99	Digital Filter	0	R/W	
P a s s C o d e	001Ah	0000~9999	Pass Code	1000	R/W	
F u n c t i o n L o c k	001Bh	0~3	Function Lock 0: none 1: User Level 2: Engineer Level 3: All	0	R/W	
[Relay Group]						
Name	Address	Range	Explain	Initial	Write/Read	Note
r y S b	001Ch	0000~9999	Start Band of Relay	0	R/W	
r y S d	001Dh	0000~5999 (0.1second)	Start Delay Time of Relay	0	R/W	
r y 1 n d	001Eh	0~5	Relay1 Energized Mode 0: oFF(no use); 1: Lo(Low Energized); 2: Hi(High Energized) 3: Lo Hold(Low Energized Hold) 4: High Hold(High Energized Hold) 5: DO(Digital Output);	2	R/W	
r y 1 H Y	001Fh	0000~5000	Hysteresis of Relay1	0	R/W	
r y 1 r d	0020h	0000~5999 (0.1second)	Energized Delay Time of Relay1	0	R/W	
r y 1 F d	0021h	0000~5999 (0.1second)	De-Energized Delay Time of Relay1	0	R/W	
r y 2 n d	0022h	0~5	Relay2 Energized Mode 0: oFF(no use); 1: Lo(Low Energized); 2: Hi(High Energized) 3: Lo Hold(Low Energized Hold) 4: High Hold(High Energized Hold) 5: DO(Digital Output);	2	R/W	
r y 2 H Y	0023h	0000~5000	Hysteresis of Relay2	0	R/W	

Name	Address	Range	Explain	Initial	Write/Read	Note
rY2rd	0024h	0000~5999 (0.1second)	Energized Delay Time of Relay2	0	R/W	
rY2Fd	0025h	0000~5999 (0.1second)	De-Energized Delay Time of Relay2	0	R/W	
rY3nd	0026h	0~5	Relay3 Energized Mode 0: oFF (no use); 1: Lo (Low Energized) 2: Hi (High Energized) 3: Lo Hold (Low Energized Hold) 4: High Hold (High Energized Hold) 5: DO (Digital Output);	1	R/W	
rY3HY	0027h	0000~5000	Hysteresis of Relay3	0	R/W	
rY3rd	0028h	0000~5999 (0.1second)	Energized Delay Time of Relay3	0	R/W	
rY3Fd	0029h	0000~5999 (0.1second)	De-Energized Delay Time of Relay3	0	R/W	
rY4nd	002Ah	0~5	Relay4 Energized Mode 0: oFF (no use); 1: Lo (Low Energized); 2: Hi (High Energized) 3: Lo Hold (Low Energized Hold) 4: High Hold (High Energized Hold) 5: DO (Digital Output); 6: Go-1.2 (Go function compare with SP1 & SP2); 7: Go-2.3 (Go function compare with SP2 & SP3);	1	R/W	
rY4HY	002Bh	0000~5000	Hysteresis of Relay4	0	R/W	
rY4rd	002Ch	0000~5999 (0.1second)	Energized Delay Time of Relay4	0	R/W	
rY4Fd	002Dh	0000~5999 (0.1second)	De-Energized Delay Time of Relay4	0	R/W	
rYrSt	002Eh		Reset for Relay Energized Hold 0: No 1: Yes	0	R/W	
RESERVED	002Fh		No use unless CS2-VA & CS2-RS			
bank			The address is for CS2-VA & CS2-RS bit1=1; Bank2 selected bit2=1; Bank3 selected bit0=bit1-bit2=0; Bank0 selected	0	R/W	
[ECI Group]						
Name	Address	Range	Explain	Initial	Write/Read	Note
EC i1	0030h	0~5	External Control Input 1 0:none (None); 1:rEL.PV (Relative PV); 2:PV.HLd (PV Hold); 3: M.rSt (Reset for Maximum & Minimum); 4:rY.rSt (Reset for Relay Hold); 5:di (Digital Input);	1	R/W	
EC i2	0031h	0~5	External Control Input 1 0:none (None); 1:rEL.PV (Relative PV); 2:PV.HLd (PV Hold); 3: M.rSt (Reset for Maximum & Minimum); 4:rY.rSt (Reset for Relay Hold); 5:di (Digital Input);	2	R/W	

External Control Input 1	0032h	0~5	External Control Input 1 0:none (None); 1:rEL.PV(Relative PV); 2:PV.HLd(PV Hold); 3: M.rSt(Reset for Maximum & Minimum); 4:rY.rSt(Reset for Relay Hold); 5:di(Digital Input);	3	R/W	
ECI debouncing	0033h	5~255	ECI debouncing 5~255 *8mSec	12	R/W	

[AO Group]

Name	Address	Range	Explain	Initial	Write/Read	Note
AO Type	0034h	0~5	Analog Output Type 0: 0~10V 1: 0~5V 2:1~5V 3: 0~20mA 4: 4~20mA 5: 0~10mA	4	R/W	
AO LS	0035h	-19999~29999	Analogue Output Low Scale	0	R/W	
AO HS	0036h	-19999~29999	Analogue Output High Scale	19999	R/W	
AO High Limit	0037h	00.00%~110.00%	Analogue Output High Limit	110.00%	R/W	
AO Clear	0038h	0~3	The clear of AO_ZERO and AO_SPAN 0: None 1: AO_ZERO 2: AO_SPAN 3: Both	0	R/W	

[RS485 Group]

Name	Address	Range	Explain	Initial	Write/Read	Note
RS485 Address	0039h	1~255	RS485 address	1	R/W	
RS485 Baud Rate	003Ah	0~5	RS485 baud rate 0:1200 1:2400 2:4800 3:9600 4:19200 5:38400	3	R/W	
RS485 Parity	003Bh	0~3	RS485 parity 0: n-8-1 1: n-8-2, 2: odd, 3: even,	1	R/W	

Square root function	003Ch	0~1	Square root function 0: no 1: yes	0	R/W	
----------------------	-------	-----	--------------------------------------	---	-----	--

Amend 2009/11/14, Add Square root function

DISCLAIMS

The information in this manual has been carefully checked and is believed to be accurate. ADtek Instruments Co., Ltd. assumes no responsibility for any infringements of patents or other rights of third parties, which may result from its use.

ADtek assumes no responsibility for any inaccuracies that may be contained in this document, and make no commitment to update or to keep current the information contained in this manual.

ADtek reserves the right to make improvements to this document and/or product at any time without notice.

No part of this publication may be reproduced, stored in a retrieval system, or transmitted in any form of or by any means, electronic, mechanical, photocopying, recording, or otherwise, without the prior written permission of ADtek Instruments Co., Ltd.

TRADEMARK

The names used for identification only maybe registered trademark of their respective companies.

Copyright © 2006 ADtek Instruments Co., Ltd. All rights reserved.

Printed in Taiwan.

Welcome to visit our web-site:

www.adtek.com.tw www.csec.com.tw

■ ADDRESS TABLE **Address number are Hexadecimal For 5-digit Display

■ User level

Name	Address	Range	Explain	Initial	Write/Read	Note
PV_H	0000h	-19999~99999	Present Value		R	
PV_L	0001h					
rY1SP_H	0002h	-19999~99999	Relay1 Set Point	50000	R/W	
rY1SP_L	0003h					
rY2SP_H	0004h	-19999~99999	Relay2 Set Point	50000	R/W	
rY2SP_L	0005h					
rY3SP_H	0006h	-19999~99999	Relay3 Set Point	50000	R/W	
rY3SP_L	0007h					
rY4SP_H	0008h	-19999~99999	Relay4 Set Point	50000	R/W	
rY4SP_L	0009h					
PuHld_H	000Ah	-19999~99999	PV Hold		R	
PuHld_L	000Bh					
n_in_H	000Ch	-19999~99999	The Minimum of PV	0	R	
n_in_L	000Dh					
n_Rh_H	000Eh	-19999~99999	The Maximum of PV	0	R	
n_Rh_L	000Fh					

■ Programming Level

[Input Group]						
Name	Address	Range	Explain	Initial	Write/Read	Note
LoSC_H	0010h	-19999~99999	Low Scale	0	R/W	
LoSC_L	0011h					
HiSC_H	0012h	-19999~99999	High Scale	19999	R/W	
HiSC_L	0013h					
PuZro_H	0014h	-19999~99999	PV ZERO	0	R/W	
PuZro_L	0015h					
PuSPn_H	0016h	-19999~99999	PV SPAN	0	R/W	
PuSPn_L	0017h					
rS485_H	0018h	-19999~99999	PV showing from RS485 command(data)	0	R/W	
rS485_L	0019h					
RoLS_H	001Ah	-19999~99999	Analogue Output Low Scale	0	R/W	
RoLS_L	001Bh					
RoHS_H	001Ch	-19999~99999	Analogue Output High Scale	99999	R/W	
RoHS_L	001Dh					
RELAY STATUS	001Eh	0~1	RELAY STATUS bit0~bit3:relay1~relay4; 0=Relay off 1=Relay on		R/W	
ECI STATUS	001Fh	0~1	ECI STATUS bit0~bit2:ECI.1~ECI.3; 0=untriged 1:triged		R	
SYSTEM STATUS	0020h		SYSTEM STATUS bit0=1 EEP fail; bit1=1 Input calibration fail; bit2=1 Input calibration NG; bit3=1 Analogue Output calibration fail; bit4=1 Analogue Output calibration NG		R	
n_rSt	0021h	0~1	Reset Maximum & Minimum Value	0	R/W	

			0:No 1:Yes			
ANALOG	0022h	0~5	The address is for CS2-PR only Analogue Input Type 0:0~10V 1:0~5V 2:1~5V 3:0~20mA 4:4~20mA 5:0~10mA	4	R/W	
ANL0	0023h	0.00~100.00%	Input Low	0.00%	R/W	
ANL1	0024h	0.00~100.00%	Input High	100.00%	R/W	
ANLDP	0025h	0~4	PV Decimal Point 0: 00000 1: 0000.0 2: 000.00 3: 00.000 4: 0.0000	0	R/W	
ANLZER	0026h	0~3	The clear of PV_ZERO and PV_SPAN 0: None 1: PV_ZERO 2: PV_SPAN 3: Both	0	R/W	
ANLMD	0027h	0~3	Display Mode 0: PV 1: Minimum Hold 2: Maximum Hold 3: RS485	0	R/W	
ANLCL	0028h	-19999~19999	Low Cut	0	R/W	
ANLAV	0029h	1~99	Average	5	R/W	
ANLDF	002Ah	0~99	Digital Filter	0	R/W	
ANLPC	002Bh	0000~9999	Pass Code	1000	R/W	
ANLFL	002Ch	0~3	Function Lock 0: none 1: User Level 2: Engineer Level 3: All	0	R/W	

[Relay Group]						
Name	Address	Range	Explain	Initial	Write/Read	Note
RYSB	002Dh	0000~9999	Start Band of Relay	0	R/W	
RYSD	002Eh	0000~5999 (0.1second)	Start Delay Time of Relay	0	R/W	
RY1ND	002Fh	0~5	Relay1 Energized Mode 0: OFF(no use); 1: Lo(Low Energized); 2: Hi(High Energized) 3: Lo Hold(Low Energized Hold) 4: High Hold(High Energized Hold) 5: DO(Digital Output);	2	R/W	
RY1HY	0030h	0000~5000	Hysteresis of Relay1	0	R/W	
RY1RD	0031h	0000~5999 (0.1second)	Energized Delay Time of Relay1	0	R/W	
RY1FD	0032h	0000~5999 (0.1second)	De-Energized Delay Time of Relay1	0	R/W	
RY2ND	0033h	0~5	Relay2 Energized Mode 0: OFF(no use); 1: Lo(Low Energized); 2: Hi(High Energized) 3: Lo Hold(Low Energized Hold) 4: High Hold(High Energized Hold) 5: DO(Digital Output);	1	R/W	
RY2HY	0034h	0000~5000	Hysteresis of Relay2	0	R/W	
RY2RD	0035h	0000~5999 (0.1second)	Energized Delay Time of Relay2	0	R/W	
RY2FD	0036h	0000~5999 (0.1second)	De-Energized Delay Time of Relay2	0	R/W	
RY3ND	0037h	0~5	Relay3 Energized Mode 0: OFF(no use); 1: Lo(Low Energized) 2: Hi(High Energized) 3: Lo Hold(Low Energized Hold)	0	R/W	

			4: High Hold (High Energized Hold) 5: DO (Digital Output);			
rY3HY	0038h	0000~5000	Hysteresis of Relay3	0	R/W	
rY3rd	0039h	0000~5999 (0.1second)	Energized Delay Time of Relay3	0	R/W	
rY3Fd	003Ah	0000~5999 (0.1second)	De-Energized Delay Time of Relay3	0	R/W	
rY4nd	003Bh	0~5	Relay4 Energized Mode 0: oFF (no use); 1: Lo (Low Energized); 2: Hi (High Energized) 3: Lo Hold (Low Energized Hold) 4: High Hold (High Energized Hold) 5: DO (Digital Output); 6: Go-1.2 (Go function compare with SP1 & SP2); 7: Go-2.3 (Go function compare with SP2 & SP3);	0	R/W	
rY4HY	003Ch	0000~5000	Hysteresis of Relay4	0	R/W	
rY4rd	003Dh	0000~5999 (0.1second)	Energized Delay Time of Relay4	0	R/W	
rY4Fd	003Eh	0000~5999 (0.1second)	De-Energized Delay Time of Relay4	0	R/W	
rYrSt	003Fh		Reset for Relay Energized Hold 0: No 1: Yes	0	R/W	
bRnE	0040h		The address is for CS2-VA \ CS2-RS & CS2-PR Bank selection bit0=1 ; Bank1 selected bit1=1 ; Bank2 selected bit2=1 ; Bank3 selected bit0=bit1=bit2=0 ; Bank0 selected	0	R/W	

[ECI Group]						
Name	Address	Range	Explain	Initial	Write/Read	Note
EC .1	0041h	0~5	External Control Input 1 0: nonE (None); 1: rEL.PV (Relative PV); 2: PV.HLd (PV Hold); 3: M.rSt (Reset for Maximum & Minimum); 4: rY.rSt (Reset for Relay Hold); 5: di (Digital Input);	1	R/W	
EC .2	0042h	0~5	External Control Input 1 0: nonE (None); 1: rEL.PV (Relative PV); 2: PV.HLd (PV Hold); 3: M.rSt (Reset for Maximum & Minimum); 4: rY.rSt (Reset for Relay Hold); 5: di (Digital Input);	2	R/W	
EC .3	0043h	0~5	External Control Input 1 0: nonE (None); 1: rEL.PV (Relative PV); 2: PV.HLd (PV Hold); 3: M.rSt (Reset for Maximum & Minimum); 4: rY.rSt (Reset for Relay Hold); 5: di (Digital Input);	3	R/W	
dEbnc	0044h	5~255	ECI debouncing 5~255 *8mSec	12	R/W	

[AO Group]						
Name	Address	Range	Explain	Initial	Write/Read	Note
RoEYP	0045h	0~5	Analog Output Type	4	R/W	

			0: 0~10V 1: 0~5V 2: 1~5V 3: 0~20mA 4: 4~20mA 5: 0~10mA			
PSRST	0046h	0~3	The clear of AO_ZERO and AO_SPAN 0: None 1: AO_ZERO 2: AO_SPAN 3: Both	0	R/W	
AO_Lmt	0047h	00.00%~110.00%	Analogue Output High Limit	110.00%	R/W	

【RS485 Group】						
Name	Address	Range	Explain	Initial	Write/Read	Note
AdRES	0048h	1~255	RS485 address	1	R/W	
BAUD	0049h	0~5	RS485 baud rate 0: 1200 1: 2400 2: 4800 3: 9600 4: 19200 5: 38400	3	R/W	
PRty	004Ah	0~3	RS485 parity 0: n-8-1 1: n-8-2, 2: odd, 3: even,	1	R/W	

※ Moving Average feature is not enlisted in the RS485 communication address table, to read or change the settings in the direct view instrument.