

Description

CPM-12 multifunction power meter provide high accuracy single phase and three-phase measuring and displaying, energy accumulating, power quality analysis, and data communication.

Hardware can be option a RS485 Modbus communication port.

Auto wiring change (**Note**) via software

CE and FCC approved

Note: Auto wiring change will be had condition limit, please refer to operation manual.

Applications

- Energy management system
- Factory automation
- Intelligent power panel
- Industrial automation
- Power Grid automation
- Community power monitoring
- Intelligent green building



Ordering Information

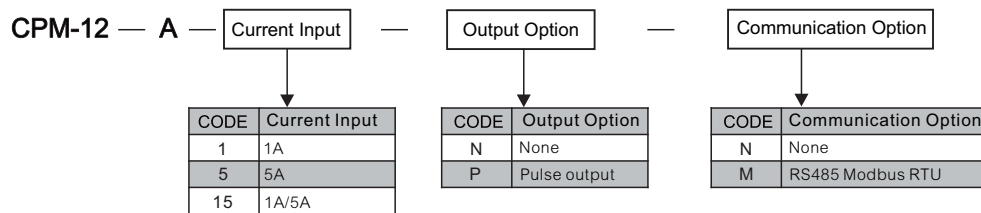

Meter Selection Guide

Measurement	
Voltage	$V_1, V_2, V_3, V_{LN,AVG} / V_{T2}, V_{T3}, V_{S1}, V_{LL,AVG}$
Current	$I_1, I_2, I_3, I_{AVG}, I_N$
Active Power	$P_1, P_2, P_3, \Sigma P$
Reactive Power	$Q_1, Q_2, Q_3, \Sigma Q$
Apparent Power	$S_1, S_2, S_3, \Sigma S$
Power Factor	$PF_1, PF_2, PF_3, PF_{AVG}$
Frequency	Hz
Active Energy	Wh Imp Wh Exp Wh Total Wh Net
Reactive Energy	Varh Imp Varh Exp Varh Total Varh Net
Apparent Energy	VAh Total
THD/Voltage (31st THD)	$THD_{V1}, THD_{V2}, THD_{V3}, THD_{V,AVG}$
THD/Current (31st THD)	$THD_{I1}, THD_{I2}, THD_{I3}, THD_{I,AVG}$
RS485	Modbus RTU mode
CO ₂	CO ₂ (Kg)
PO	Pulse Output

Accuracy & Resolutions

PARAMETER	ACCURACY	RESOLUTION	MEASUREMENT RANGE
Voltage	0.5%	0.1V	40.0~400.0V _{ac} (V _{LN})
Current	0.5%	0.001A	1%~120% CT rating current
Neutral Current	1.5%	0.001A	1%~120% CT rating current
Active Power	1.0%	1W	-999999999~999999999W
Reactive Power	1.0%	1Var	-999999999~999999999Var
Apparent Power	1.0%	1VA	0~999999999VA
Power Factor	1.0%	0.001	-0.020~+1.000~0.020
Frequency	0.2%	0.01Hz	45.00~65.00Hz
Active Energy	1.0%	0.1kWh	0~9999999.9kWh
Reactive Energy	1.0%	0.1kVarh	0~9999999.9kVarh
Apparent Energy	1.0%	0.1VAh	0~9999999.9VAh
THD	1.0%	0.1%	0~100.0%

Technical Specification

Electrical Characteristics

Measurement: True RMS
 Sampling: 128 point/Cycle
 Metering system type: 1P2W, 1P3W, 3P3W(1/2/3CT), 3P4W(1/3CT)
 Balance / Unbalance
 Input range: Voltage: 40~400V_{LN}, 60~600V_{LL}
 PT Primary side ratio: 100~1200000V
 PT Secondary side ratio: 50~500V
 Current: 0~5A / 0~1A
 CT Primary side ratio: 5~9999A
 Frequency: 45~65Hz

Metering over range: Voltage: 2x rated voltage continuous
 2500V, 1sec
 Current: 2x rated current continuous
 20x rated current 1sec

Input load: Voltage: <0.2VA Current: <0.1VA

Power Quality

THD: Total harmonic distortion for voltage and current

RS485 Communication

Protocol: RS485 Modbus RTU mode
 Address: 1~247
 Baud rate: 1200/2400/4800/9600/19200/38400 bps
 Parity: None / Even / Odd
 Data bits: 8 bits
 Stop bit: 1 or 2
 Distance: 1200M max
 Terminate resistor: 120~300Ω/0.25W(typical: 150Ω)

Memory storage: FRAM

Pulse Output

Output type: Open collector (O.C.) 40V_{dc} / 50mA
 Parameter for output: Import active energy, Export active energy
 Import reactive energy, Export reactive energy
 1~9999 (x0.1 kWh or kVarh)
 Pulse divider: 0~5000(mS), 0 is 50% duty cycle
 Test pulse output: 1600 Pulse / 1kWh, duty cycle 50%

Power Supply

Range: AC 85~264V / DC 100~300V
 Power consumption: AC: ≤10VA @ 230V / DC: ≤3W

Environmental Characteristics

Operating Temp.: 0~60°C
 Humidity rating: 5~95%RH, Non-condensing
 Temp. coefficient: ≤100 ppm/°C
 Storage Temp.: -10~70°C
 IP Enclosure: Front panel: IEC 529 (IP50), Housing: IP20

Mechanical Characteristics

Dimensions: 96mm(W)x96mm(H)x70.5mm(L)
 Panel cutout: 90mm(W)x90mm(H)
 Material: PC, Black (with fire-retardant)
 Mounting: Panel mounting
 Weight: ≤400g



Safety

Isolation: AC 2KV, 50/60Hz, for 1 min, Between Power / Input / Output / Case

Insulation resistance: $\geq 100M\Omega @ 500V_{dc}$

EMC: EN 61326-1:2013
 CISPR11 Class A
 EN61000-3-2:2014 EN61000-3-3:2013
 IEC61000-4-2:2008
 IEC61000-4-3:2006+A1:2007+A2:2010
 IEC61000-4-4:2012 IEC61000-4-5:2005
 IEC61000-4-6:2013
 IEC61000-4-8:2009 IEC61000-4-11:2004

FCC: FCC part 15 subpart B Class A

LVD: EN61010-1:2010

Wire terminal: PA66 (UL 94V-0)
 Voltage / Current input:
 AWG: 26~10 / 0.5~4.0mm²
 Screw Torque Value: M3 / 8.0kgf.cm(Max)
 Others input:
 AWG: 28~16 / 0.5~1.5mm²
 Screw Torque Value: M2 / 2.04kgf.cm(Max)

Connection Diagram

Aux Power

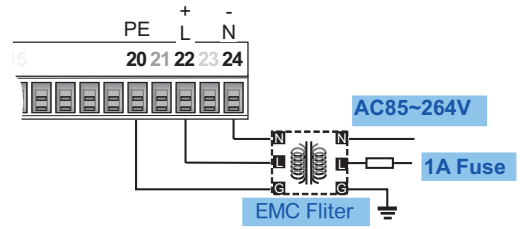

Voltage and Current input

● 1P2W - [1P2W]

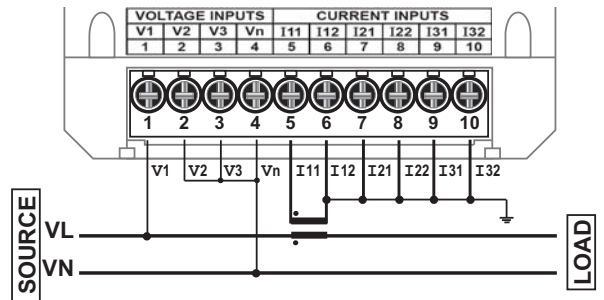

● 1P3W - [1P3W]

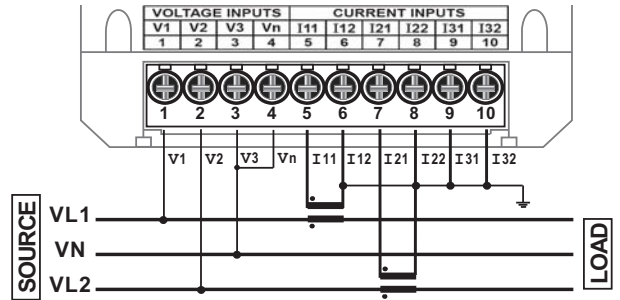

● 3P3W - 2PT / 3CT [3P3W3CT]

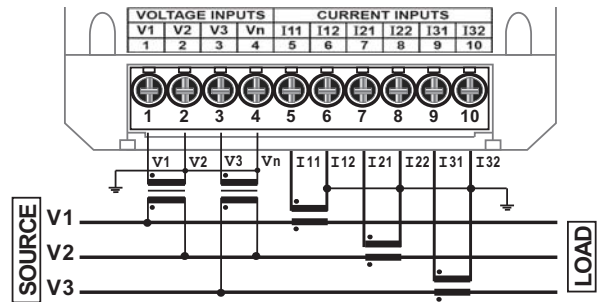

● 3P3W - W/O PT / 3CT [3P3W3CT]

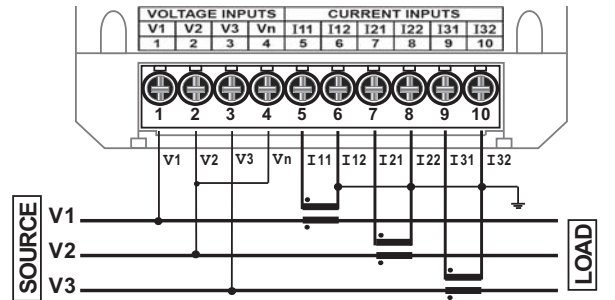

Front Panel

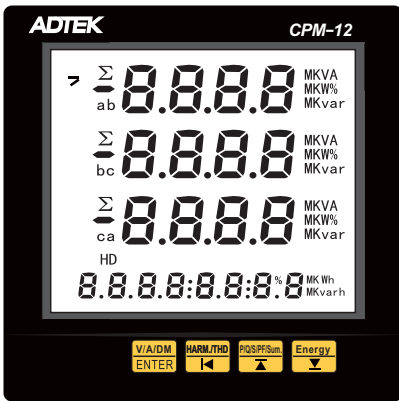

Display: LCD 65(W)x61(H)mm ; White back light blue words visible.
 Backlight delay time : 0~15 min ("0" is always on).

Dimensions

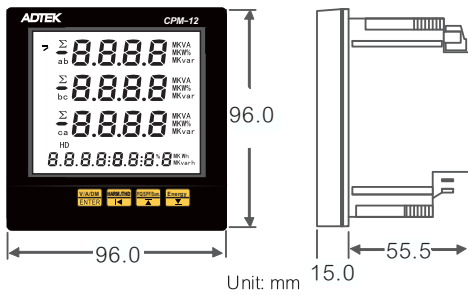

Installation

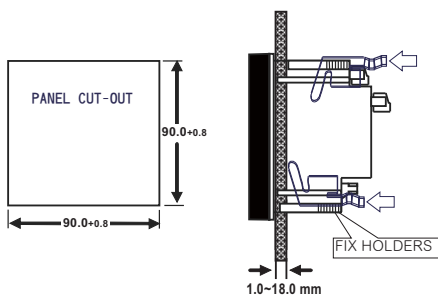

● 3P3W- 2PT / 2CT [3P3W2CT]

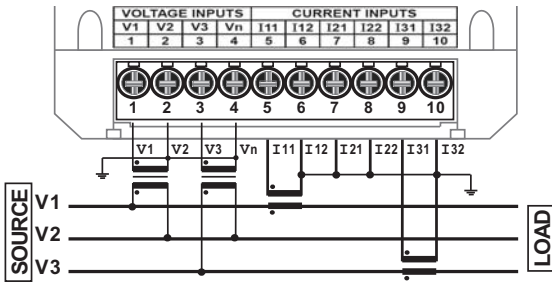

● 3P3W -W/O PT / 2CT [3P3W2CT]

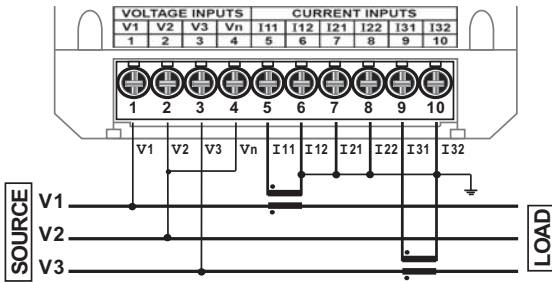

● 3P3W - 2PT / 1CT [3P3W1CT]

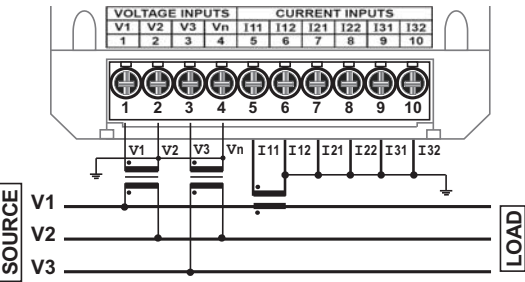

● 3P4W - 3PT / 3CT [3P4W3CT]

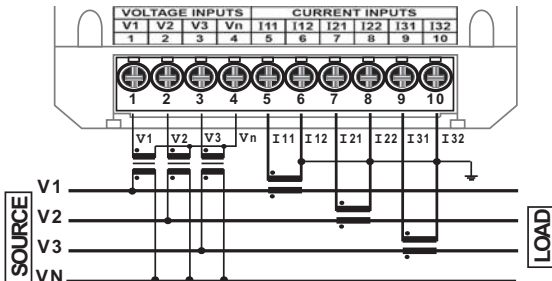

● 3P4W - 3PT / 1CT [3P4W1CT]

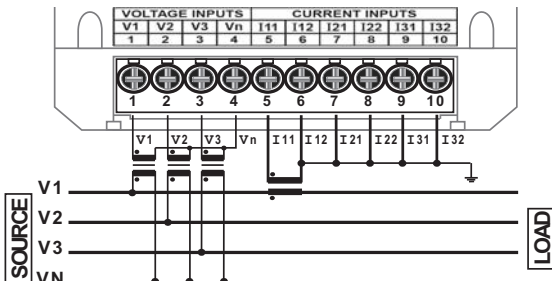

※This CT connection is available use for Inverter load or normal load situation

● 3P3W - 2PT / 2CT [3P3W2CT]

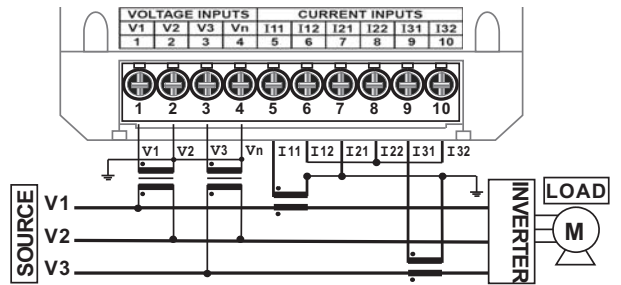

● 3P3W -W/O PT / 2CT [3P3W2CT]

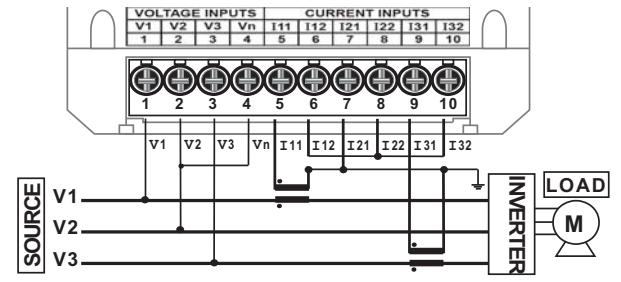

● 3P3W - W/O PT / 1CT [3P3W1CT]

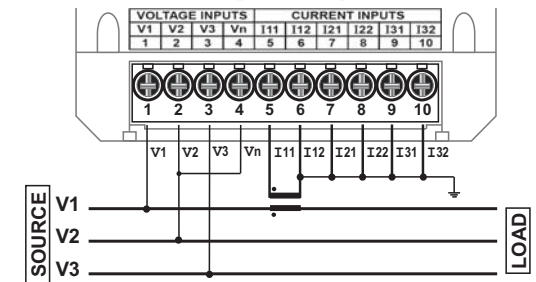

● 3P4W - W/O PT / 3CT [3P4W3CT]

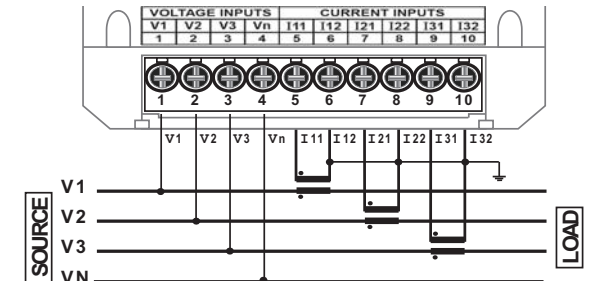

● 3P4W - W/O PT / 1CT [3P4W1CT]

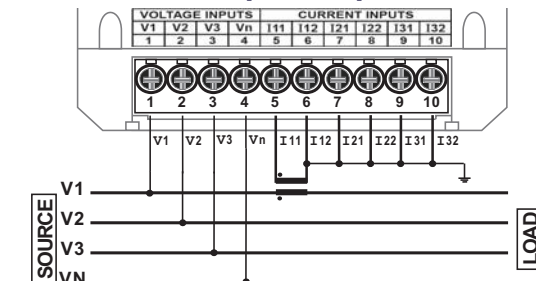

Pulse output

Wire: AWG 28~16 (0.5~1.5mm²)

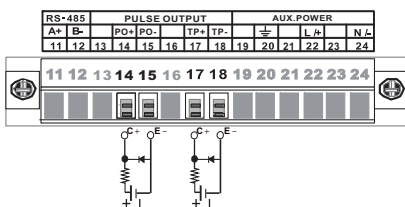

RS485 Communication port

Wire: AWG 28~16(0.5~1.5mm²)

A+ B-

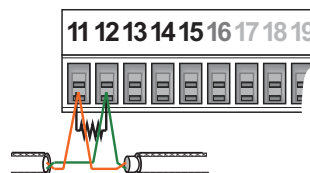

Distance Max. : 1200M
Terminator : 120~300Ω/0. 25W
(Standard: 150Ω)