

# AEM-DRB

## Multi Circuit Power Meter(DIN rail)

### Operation Manual



# Content

Chapter 1 Product Overview.....	1
1.1 Foreword.....	1
1.2 Outward & Instructions.....	1
1.3 Warning & Criterion.....	2
Chapter 2 Specifications.....	4
2.1 Electrical Spec.....	4
2.2 Communication Spec.....	5
2.3 Operation Interface.....	6
2.3.1 Interface Tree .....	6
2.4 Physical Dimensions.....	8
Chapter 3 Installation.....	10
3.1 Installation Method.....	10
3.1.1 Environment .....	10
3.1.2 Remind .....	10
3.2 Basic Test.....	11
3.3 Wiring Instructions.....	12
3.3.1 Wiring Diagram .....	12
3.3.2 Communication Property .....	16
Chapter 4 Operations.....	17
4.1 General Operations.....	17
4.1.1 Reading Measured Data .....	17
4.1.1.1 Summary Search .....	17
4.1.1.2 Metering Search .....	17
4.1.1.3 Power Parameter Search .....	18
4.1.1.4 Alarm Search .....	19
4.1.2 Data Clear & Reset .....	19
4.1.3 Power Meter Info Search .....	20
4.1.4 USER PASSWORD .....	20
4.1.5 General .....	20
4.1.5.1 Wire System .....	20
4.1.5.2 Voltage Transformer Setting .....	21
4.1.5.3 Current Transformer Setting .....	21

4.1.5.4	Branch Loop Voltage Phase Assign .....	22
4.1.5.5	Modify Password .....	22
4.1.5.6	Default Page .....	22
4.1.5.7	Current Low-cut .....	23
4.1.6	Communcion .....	24
4.1.6.1	Address .....	24
4.1.6.2	Baudrate .....	24
4.1.6.3	Parity .....	25
4.1.6.4	IP Address .....	25
4.1.6.5	Module Control .....	26
4.1.7	Pulse Output .....	26
4.1.7.1	Test Pulse .....	26
4.1.7.2	Target Loop .....	26
4.1.7.3	Energy Type .....	27
4.1.7.4	Pre-Divider .....	27
4.1.7.5	High Time .....	27
4.1.8	Energy Unit .....	27
4.1.9	Date/Time .....	28
4.1.9.1	Backlight Time .....	28
4.1.9.2	Date .....	28
4.1.9.3	Time .....	28
4.1.9.4	Operation Hour Reset .....	28
4.1.9.5	Running Hour Reset .....	29
4.1.10	Demand .....	29
4.1.10.1	Mode .....	29
4.1.10.2	Period .....	29
4.1.11	Input/Output .....	29
4.1.11.1	Digital Input .....	29
4.1.11.2	Relay Output .....	30
4.1.12	Initial .....	31
4.2	Measurement algorithm.....	32
4.2.1	Harmonic .....	32
4.2.2	Demand .....	32
4.2.2.1	Sliding Block .....	32
4.2.2.2	Fix Block .....	33

4.3	Block transfer function.....	33
4.4	Data Logging function.....	33
4.4.1	Data logging function setting .....	34
4.4.2	Data log read .....	37
4.5	Time of use (TOU) Function.....	38
4.5.1	Season Setting .....	38
4.5.2	TOU Season Format .....	39
4.5.3	Schedule Setting .....	39
4.5.4	Segment Setting .....	39
4.5.5	Tariff Setting .....	39
4.5.6	Holiday Setting .....	39
4.5.7	Holiday schedule .....	40
4.5.8	Weekend Schedule .....	40
4.5.9	Demand .....	40
4.5.10	TOU Settlement .....	40
Chapter 5	Message of Abnormal Operations.....	41
5.1	Common malfunction analysis.....	41
5.1.1	Power meter dosen't work after it's electrified	41
5.1.2	Voltage or current reading in incorrect .....	41
5.1.3	Power or power factor reading is incorrect, but .. voltage and current are correct .....	41
5.1.4	RS-485 communication is unusual .....	41

# Chapter 1 Product Overview

## 1.1 Foreword

Thank you for using this product, this meter interface installation manual provides information on the AEM-DRB meter. The AEM-DRB multi circuit power meter is used for power distribution (electric power system) monitoring and control in various industries. Suitable for measuring CAT II power system.

Before using, please carefully read this manual to ensure that it is used correctly. The following matters must be observed before you have read this manual:

- The installation environment must be free of moisture, corrosive gases and flammable gases.
- When wiring, please follow the wiring diagram to explain the construction.
- The grounding project must be implemented, and the grounding must be carried out in accordance with the current state.
- Do not dismantle the meter or change the wiring while power is on.
- Do not touch the power supply during power-on operation to avoid electric shock.
- If you still have problems using it, please contact your dealer or our customer service center. Due to the constant improvement of the product, please contact your dealer or the website (<http://www.adtek.com.tw>) to download the latest version when the content specifications are corrected.

## 1.2 Outward & Instructions

The AEM-DRB has a liquid crystal display screen that displays five measurement data per page

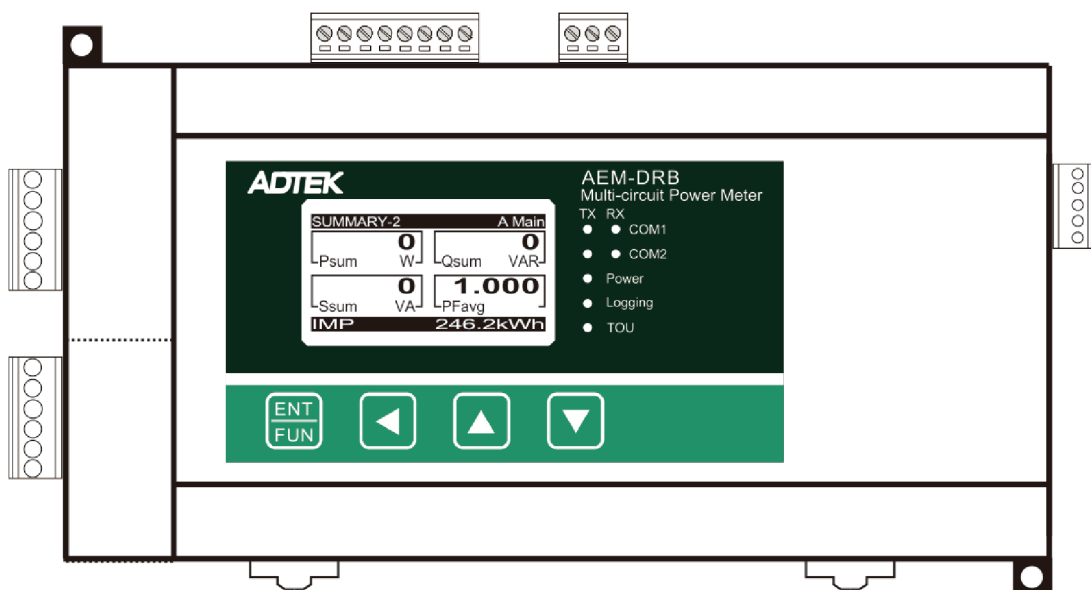

## 1.3 Warning & Criterion

- Installation attention



- Beware of potential hazards. Wear safety equipment properly when operating this device and follow safety standards and related regulations for operating electric equipment.
- Installation of this device should be performed by licensed professionals. Perform operations only after carefully reading this manual.
- Operate this device according to this manual to prevent improper operation that may cause damage and bodily harm.
- This device should be installed in a properly-insulated fire-protection cabinet.

- Operation attention



- Do not operate alone.
- Power should be disconnected before installing, checking, or maintaining this device.
- You must use a voltage checking device with the correct rated values to ensure that all power has been disconnected.
- Before connecting power, check that all mechanical parts, covers, and doors have been returned to their original states. Make sure there are no parts or tools left inside the device.

- Wiring attention



- When using the equipment, potential transformer for secondary side is prohibited short circuit.
- When using the equipment, current transformer must not be under an open circuitaa.
- When using the equipment, please make sure current transformer for secondary side has been locked on the equipment. To avoid the main trunk line falling off during use, causing equipment damage.
- When used with a current transformer (CT), please use a current transformer (CT) that meets UL2808 in the United States/Canada, and use a current transformer (CT) that meets the requirements of IEC61869-2 or AHJ in other countries to ensure use Safety.

- Wiring method



- When measuring current, a current transformer must be used with the device.
- When the measured voltage exceeds the rated range (line voltage of 35~690V AC L-L, phase voltage: 20~350V AC L-N) for this device, a potential transformer must be used with the device.
- For the wrong forced pull-out of the wire, re-check the connecting wire and start again.

- Maintenance and inspection



- Disconnect all wiring (or power off all other circuits) that may present potentially hazardous voltage levels to the unit when cleaning the power meter. Ensure to use a dry and soft cotton cloth to wipe the surface of the power meter carefully.

# Chapter 2 Specifications

## 2.1 Electrical Spec.

Accuracy Class					
Quantity of electricity	Voltage	0.2 %	Electrical energy	Active energy	Class 0.5S
	Current	0.2 %		Reactive energy	Class 0.5S
	Neutral line current	0.1 %		Apparent energy	0.5 %
	Active power	0.5 %	THD		1.0 %
	Reactive power, apparent power	0.5 %	Individual harmonic		1.0 %
Power Factor		0.5 %	Three-phase unbalance		0.5 %
Active power demand		0.5 %	Frequency accuracy		0.05 %
Apparent power demand		0.5 %	Current demand	0.2 %	
Reactive power demand		0.5 %			
Input					
Wiring method	Single-phase two-wire, 1 CT		Three-phase three-wire, $\Delta$ Delta-connection, 2 CT, 2 PT		
	Single-phase three-wire, 2 CT		Three-phase three-wire, $\Delta$ Delta-connection, 1 CT, 2 PT		
	Three-phase three-wire, $\Delta$ Delta-connection, 3 CT, No PT		Three-phase four-wire, Y-connection, 3 CT, 3 PT		
	Three-phase three-wire, $\Delta$ Delta-connection, 2 CT, No PT		Three-phase four-wire, Y-connection, 1 CT, 3 PT		
	Three-phase three-wire, $\Delta$ Delta-connection, 1 CT, No PT		Three-phase four-wire, Y-connection, 3 CT, No PT		
	Three-phase three-wire, $\Delta$ Delta-connection, 3 CT, 2 PT		Three-phase four-wire, Y-connection, 1 CT, No PT		
Voltage	Line voltage: $\leq 690$ VAC (L-L) Phase voltage: $\leq 400$ VAC (L-N)		Current	1A / 5A / 333mV	
Frequency	45~65 Hz				
Operation	Measuring Category : CAT II				
Alarm	Alarm parameters selectable		12 kinds of alarms selectable		
Max/Min	Main loop: 44/40		Max/Min, Time stamp		
	Sub loop: 40		Max, Time stamp.		
Power	Functional Range		85~264 VAC (Power Consumption 15VA), 100~300 VDC (Power Consumption 5W)		
Frequency	Working Power Frequency		50/60 Hz		
Communication Interface	RS-485 Interface		MODBUS-RTU		
			Baud Rate 1200 / 2400 / 4800 / 9600 / 19200 / 38400 / 57600 / 115200 bps		
	Ethernet Interface		Single or dual port, 10/100M BASE-TX RJ45 connector, Daisy-chaining capability		
			Modbus TCP		
		TCP socket: 4 sockets			
Exterior	Dimensions (W x H x D)		118 * 77* 199 mm		
	IP Protections		IP20		
	Weight: 5A main loop: 735g; 333mV main loop: 685g				

Environment	Operating Temperature	0°C ~ +60°C (32 °F ~ 140 °F )
	Storage Temperature	- 10 °C ~ +70 °C (14 °F ~ 158 °F )
	Relative Humidity	5~ 95 % RH Non-condensing
	Altitude	Below 2000 meters

Display	
Screen display type	LCD display
Background light	White backlight

Electromagnetic compatibility	
Electrostatic discharge	IEC 61000-4-2:2008
Immunity to radiated fields	IEC 61000-4-3:2006+A1:2007+A2:2010
Immunity to fast transients	IEC 61000-4-4:2012
Immunity to impulse waves	IEC 61000-4-5:2014+A1:2017
Conducted immunity	IEC 61000-4-6:2013/COR1:2015
Immunity to magnetic fields	IEC 61000-4-8:2009
Immunity to voltage dips	IEC 61000-4-11:2004/A1:2017
Radiated emissions	FCC part 15 subpart B Class A
Conducted emissions	FCC part 15 subpart B Class A
Harmonics emissions	EN 61000-3-2:2014
Flicker emissions	EN 61000-3-3:2013

Electrical safety	
LVD	EN61010-1:2010+A1:2019

Accuracy Standard	
Measurement accuracy	IEC 61557-12 : 2018/AMD1 : 2021
Active energy	Class 0.5S(IEC 62053-22:2020)
Reactive energy	Class 0.5S(IEC 62053-24:2020)

## 2.2 Communication Spec.

Communication	
RS-485	MODBUS RTU
Baud Rate	1200 / 2400 / 4800 / 9600 / 19200 / 38400 / 57600 / 115200 bps

## 2.3 Operation Interface

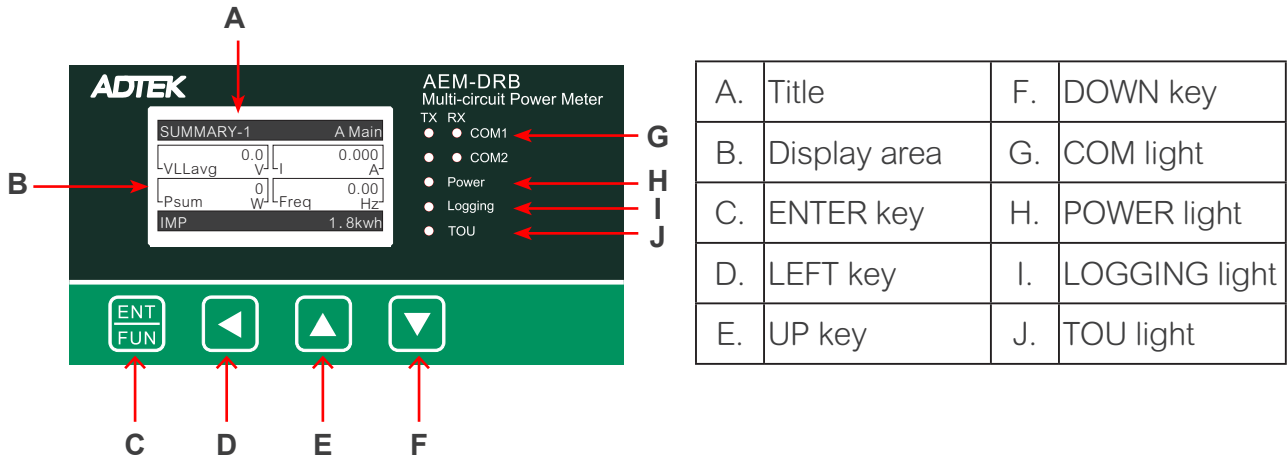

Button Name	General Mode	Configuration Mode
ENTER	Menu key	Confirm the input and return to the previous page
LEFT	None	Long press for 2 seconds to abandon input or return to the previous page
UP	Summary page switching key	Select item or increase number
DOWN	Summary page switching key	Select item or decrease number

### 2.3.1 Interface Tree

Display UI interface tree

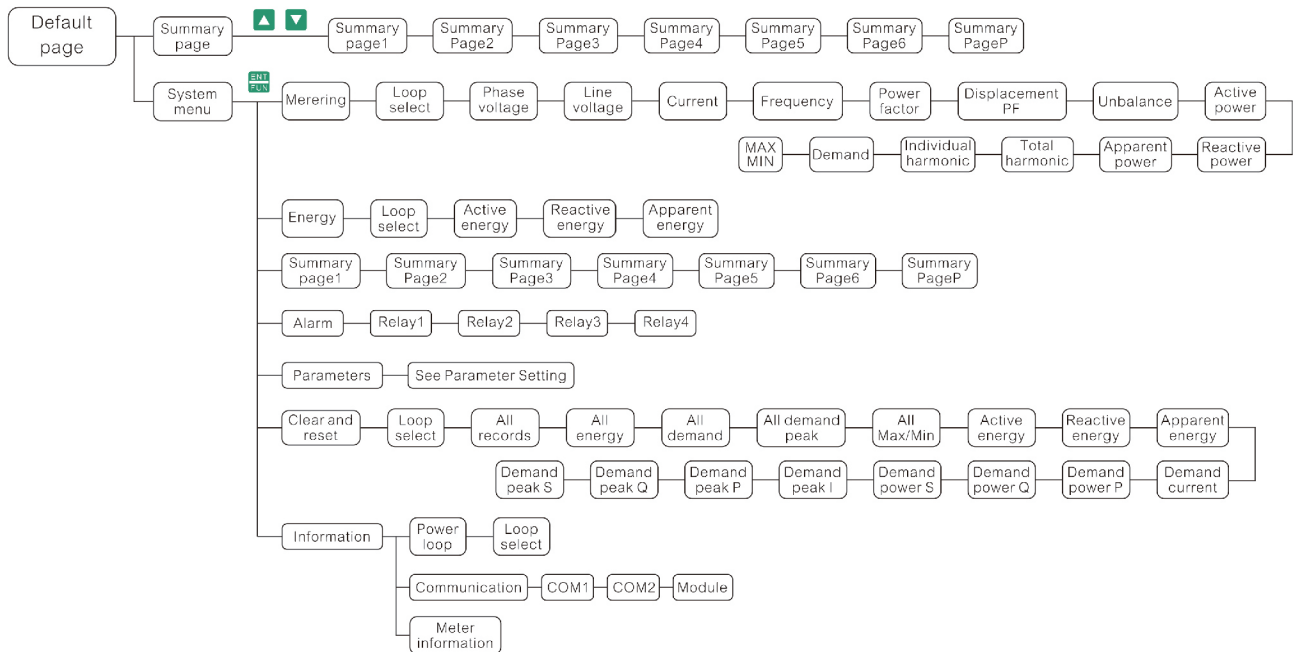

# Setting UI interface tree

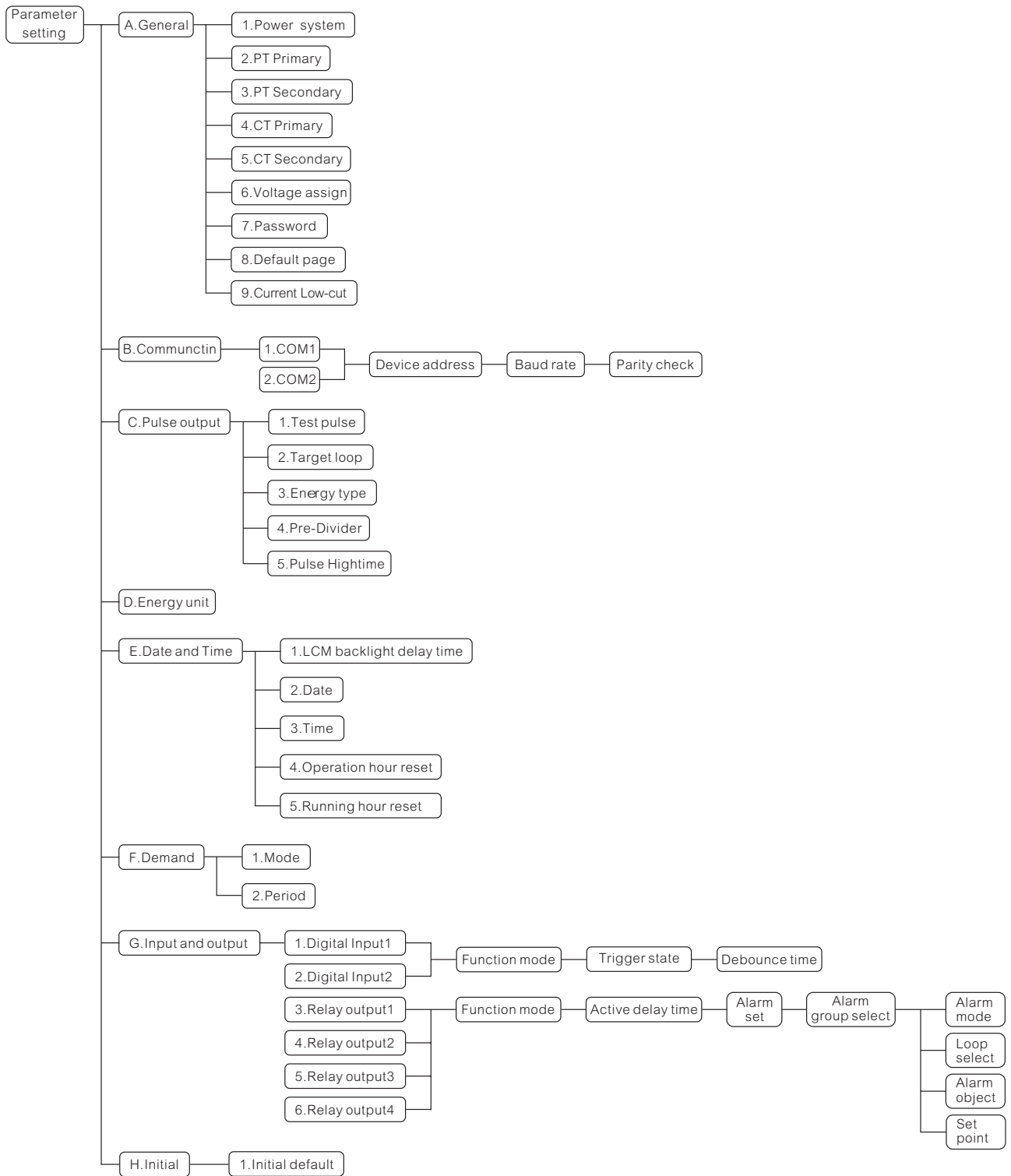



# Output and Input

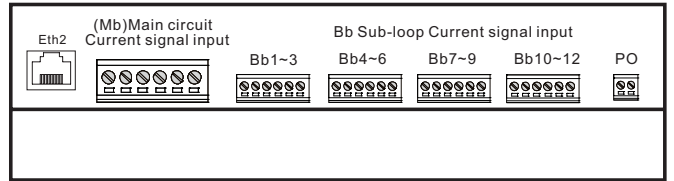
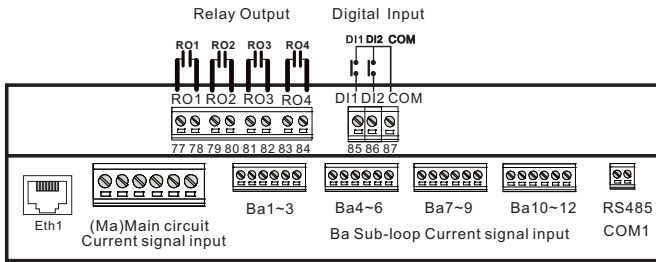
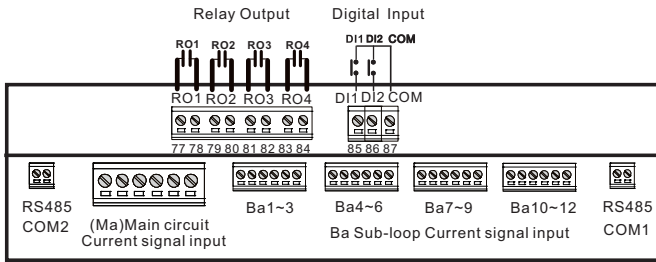

## RS485 Communication Port:

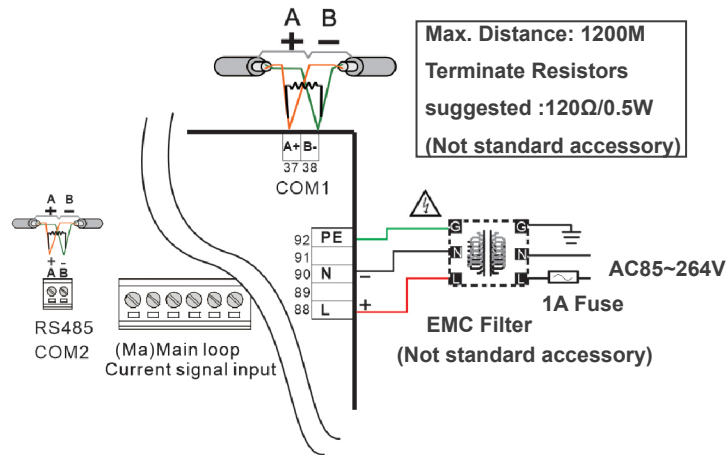

## Pulse Output:

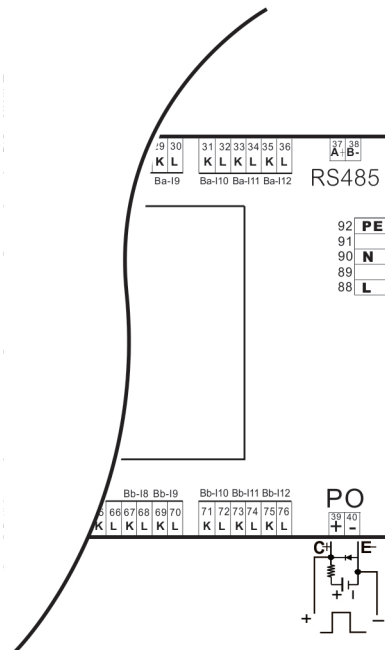

# Chapter 3 Installation

## 3.1 Installation Method

### 3.1.1 Environment

This product must be placed in the box when it is not in use. If it is not used for the time being, in order to make the product conform to the warranty scope and future maintenance of the company, please pay attention to the following matters during storage:

- Must be placed in a dust-free, dry place.
- The ambient temperature in the storage location must be kept in the range of -10 °C to +70°C (14 °F to 158 °F ).
- The relative humidity in the storage location must be kept in the range of 5% to 95% without condensation.
- Keep the storage away from the environment containing corrosive gas and liquids.
- It is best to properly store in a rack or countertop.
- Suitable installation environments for this product include: places where there is no high heat device; locations where there is no water droplets, vapors, dust, and oily dust; places where there is no corrosion, flammable gas, liquids; and where there is no floating dust and metal particles Places; Strong, vibration-free, electromagnetic noise-free places.

### 3.1.2 Remind

- Installation method must be in accordance with the regulations, or it could cause malfunction.
- To make sure the cooling loop work well, when installing the electric meter, it is necessary to keep sufficient space between the upper and lower side of the meter and the adjacent items and baffles (wall) or it will cause poor heat dissipation.

### 3.2 Basic Test

Test Item	Description
General Testing	<ul style="list-style-type: none"> <li>• Heat sink holes should be avoided by foreign substances such as oil, water or metal powder and should be prevented from falling into the electric meter.</li> <li>• If the electric meter is set up in a place where harmful gases or dust are present, it shall prevent the intrusion of harmful gases and dust.</li> </ul>
Pre-operation (No control power supply)	<ul style="list-style-type: none"> <li>• Please insulate the connection part of the wiring terminal.</li> <li>• The communication wiring should be correct, otherwise abnormal actions may occur.</li> <li>• Check for conductive or flammable objects such as screws or metal plates inside the meter.</li> <li>• When the electronic instrument used near the meter is subjected to electromagnetic interference, adjust the instrument to reduce electromagnetic interference.</li> <li>• Please make sure the meter's supply voltage level is correct.</li> </ul>
Pre-operation (Control power supplied)	<ul style="list-style-type: none"> <li>• Make sure the communication with each device is normal.</li> <li>• If the meter is abnormal, please contact your dealer or our customer service center.</li> </ul>

### 3.3 Wiring Instructions

#### 3.3.1 Wiring Diagram

- Note

1. To avoid electric shock, do not change the wiring while the power is on.
2. Since the power meter does not have a power switch, be sure to install a circuit breaker switch on the power cord of the meter.
3. Measuring Voltage: When the measuring voltage is higher than the rated specification range that this equipment can carry, must use an external voltage transformer (PT).
4. Measuring current: Measuring the current requires the use of an external current transformer (CT).

The recommended wiring material is as follows:

Terminal Block	Wire gauge	Screw torque	Wire temperature resistance
Branch loop current, RS-485	AWG 28 ~ 14	2.04 kgf.cm (0.2 N· m)	70°C or higher
Aux. power, Measured voltage, RO, DI, PO, Main loop current	AWG 28 ~ 12	5.202 kgf.cm (0.5 N· m)	70°C or higher

- Wiring method

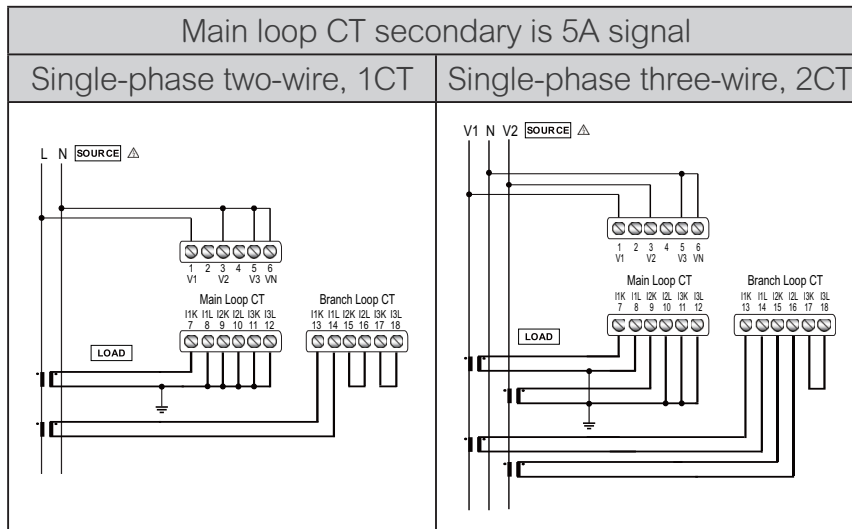

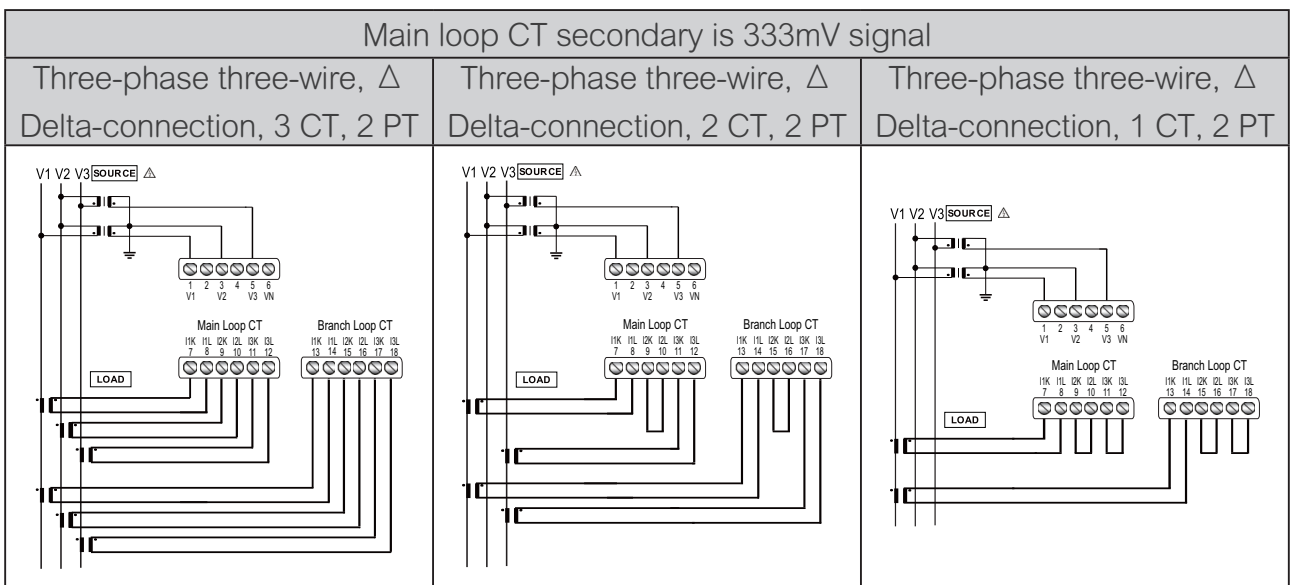
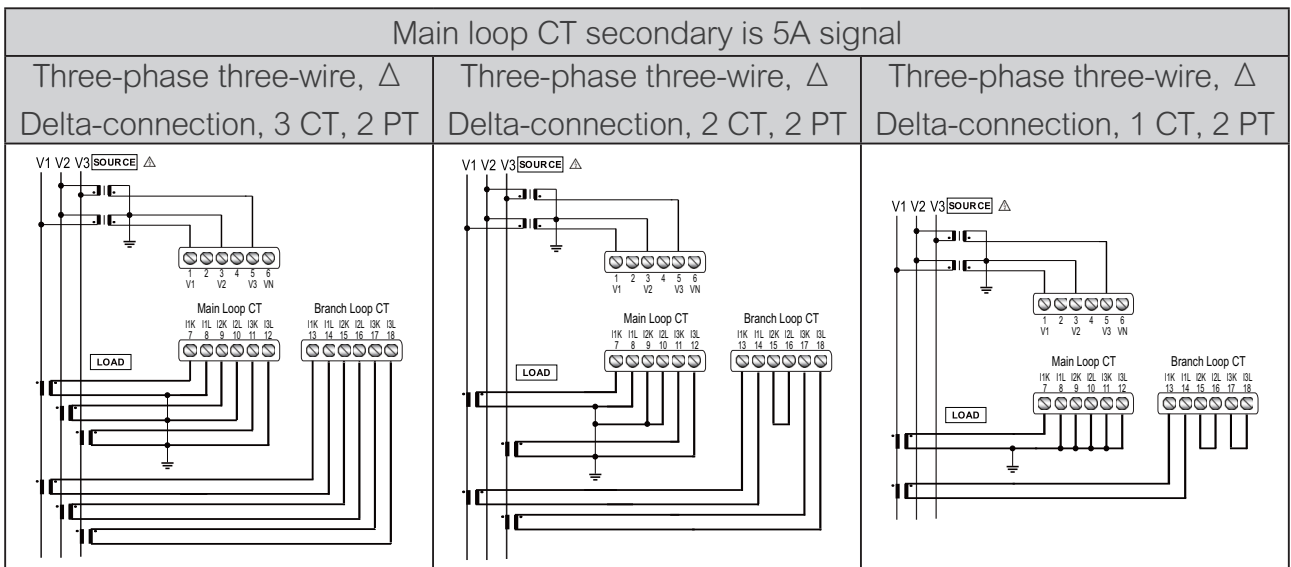
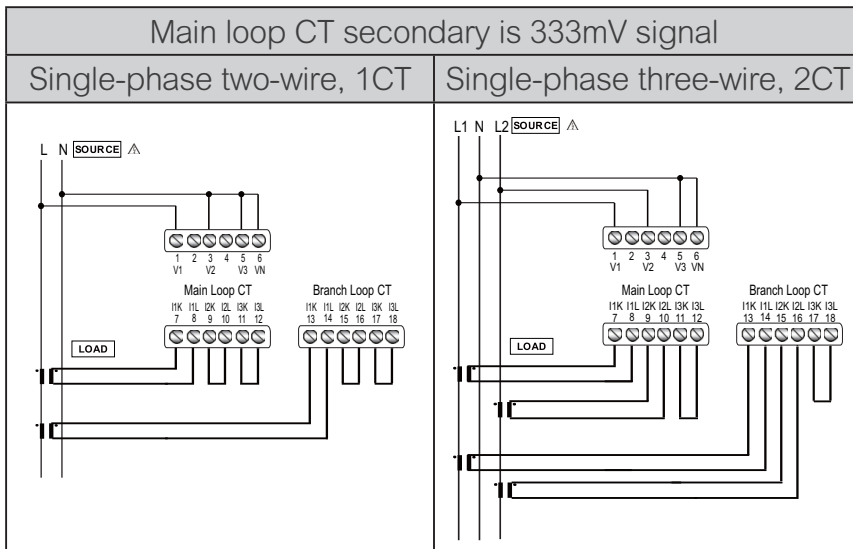

Main loop CT secondary is 5A signal

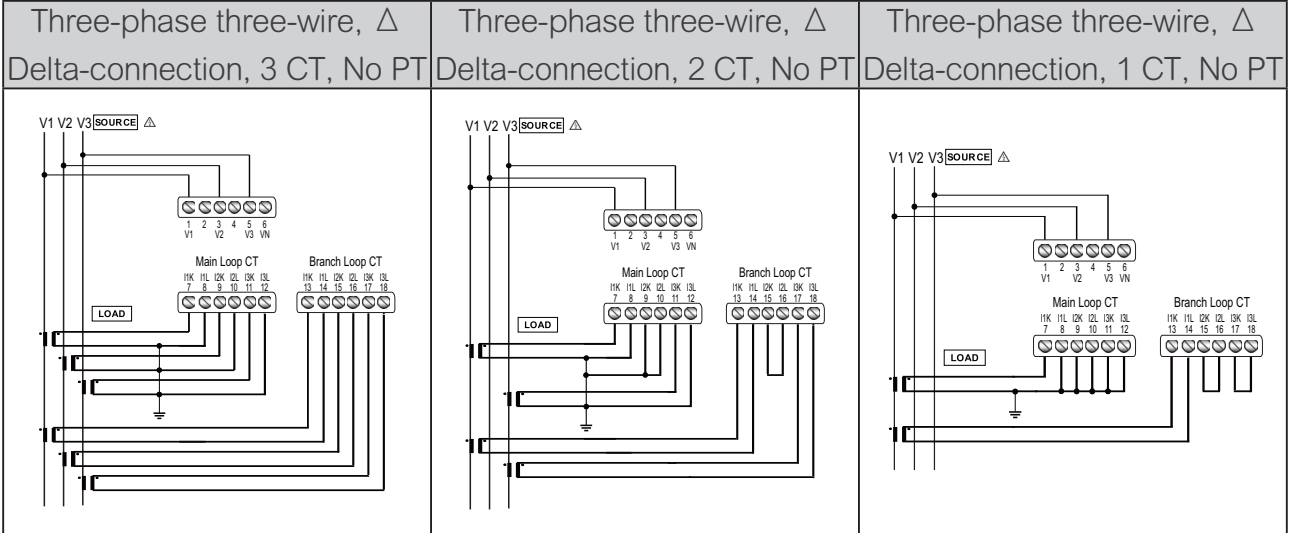

Main loop CT secondary is 333mV signal

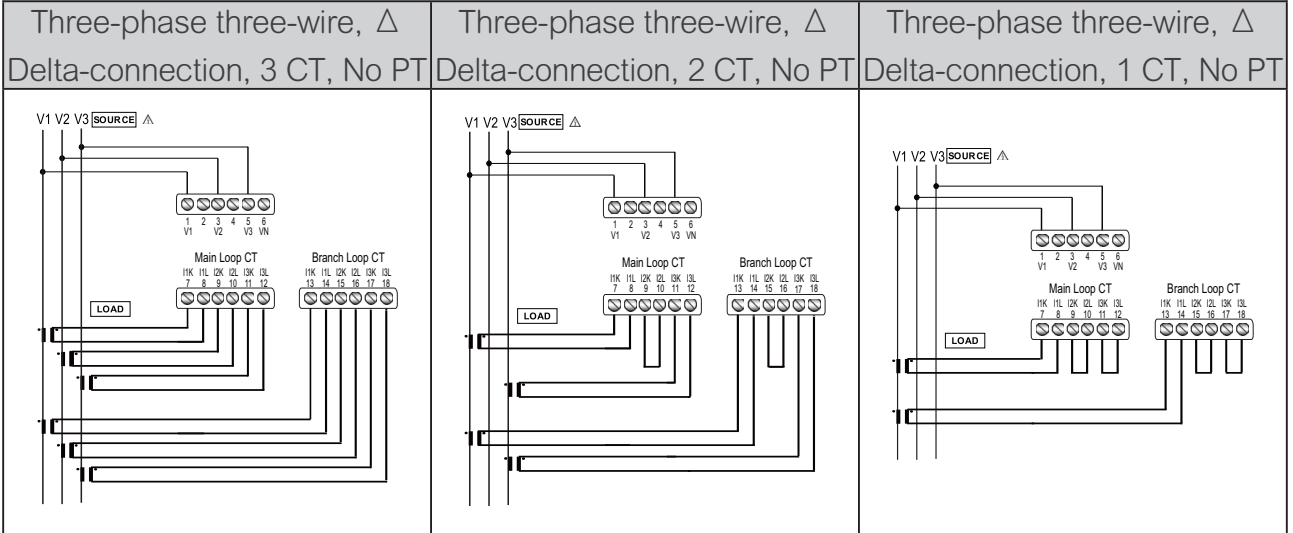

Main loop CT secondary is 5A signal

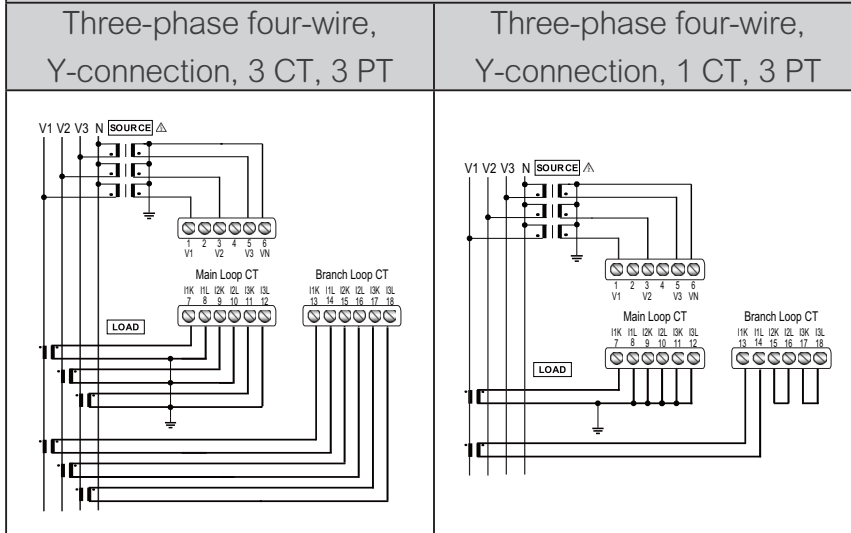

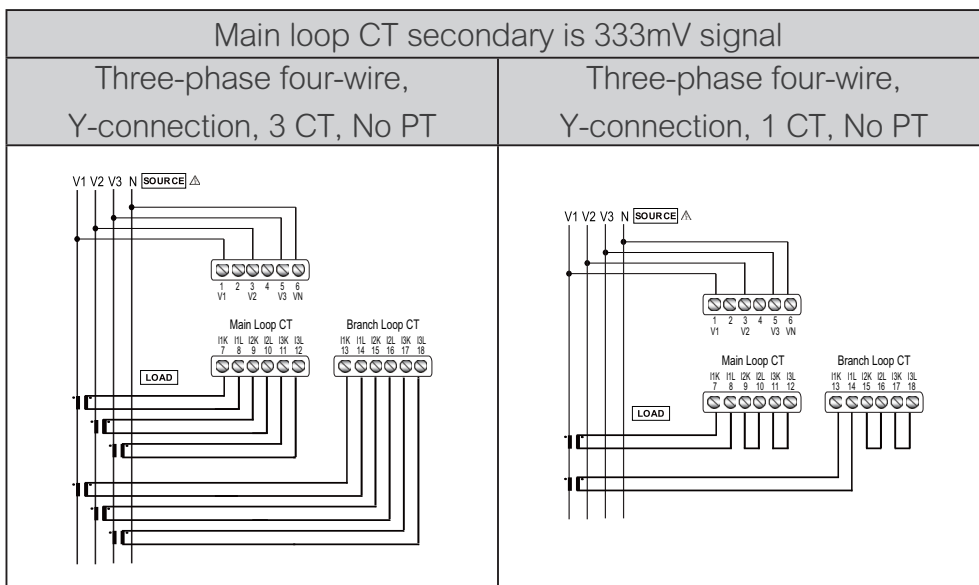
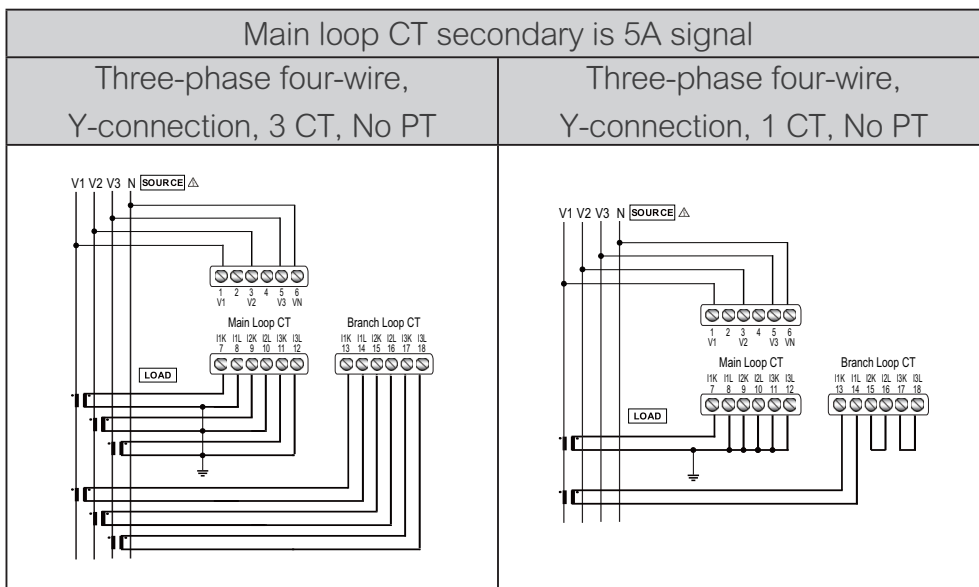
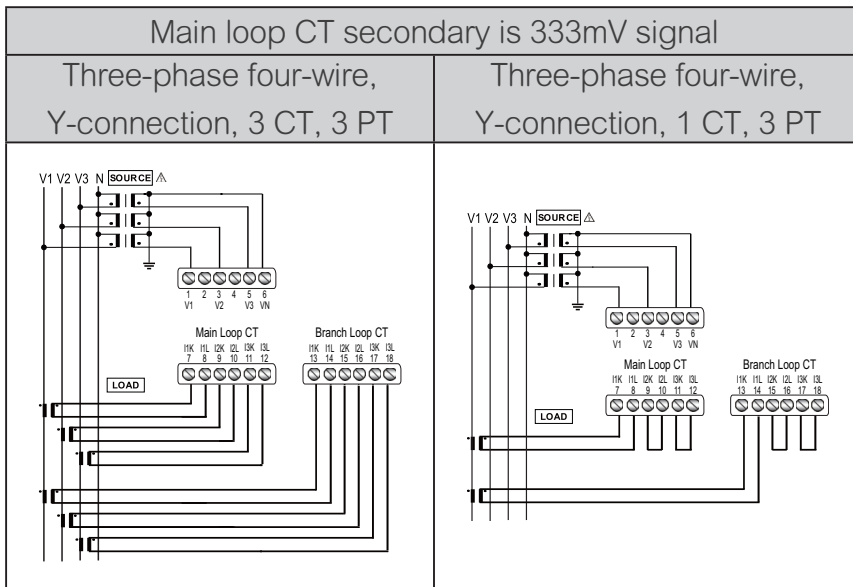

- PO connection
- RO connection

- DI connection

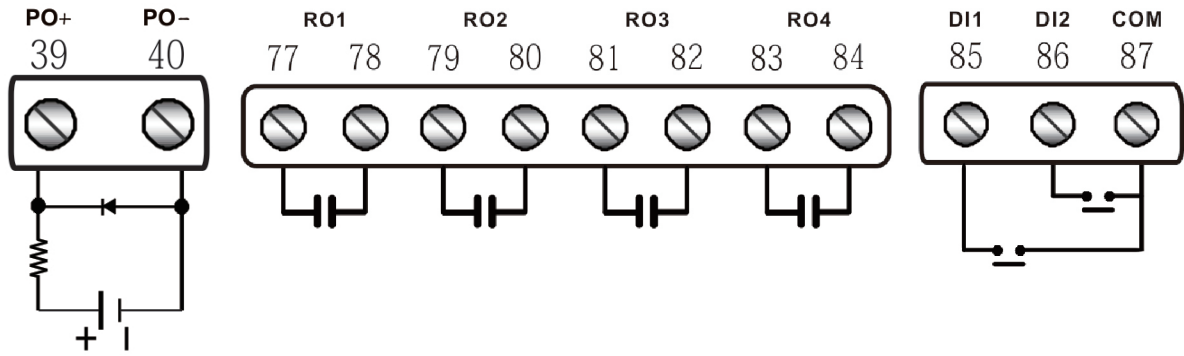

Use the following symbol in the figure:

Symbol			
Description	GND	CT	PT

### 3.3.2 Communication Property

- Communication Specifications:

Max distance of communication	1200 m	Baud Rate	1200, 2400, 4800, 9600, 19200, 38400, 57600, 115200
Max number of connected stations	32	Data Bit	8
Communication Protocols	MODBUS RTU	Parity	None \ Odd \ Even
Functional Code	03, 06, 10	Stop Bit	1 \ 2

- Communication property of RS-485 must use twist-pair.
- The communication property D+ terminal of all devices needs to be connected to the same twisted-pair , the D- terminal needs to be connected to another twist-pair, the isolation net ground treatment, and the terminal equipment needs to be loaded with terminal resistance.
- Please use 22~18 AWG at wiring terminal.

# Chapter 4 Operations

## 4.1 General Operations

### 4.1.1 Reading Measured Data

#### 4.1.1.1 Summary Search

In the main screen, press the UP or DOWN key to switch the following comprehensive display measurement pages.

- Summary-1: Specify loop of summary the measurement parameters, including VLLavg, lavg, Psum, Freq.
- Summary-2: Specify loop of summary the measurement parameters, including Psum, Qsum, Ssum, PFavg.
- Summary-3: Specify loop of summary the measurement parameters, including VLLavg, lavg, Psum, PFavg.
- Summary-4: Specify loop of summary the measurement parameters, including VLLavg, lavg, Psum, Freq.
- Summary-5: Specify loop of summary the measurement parameters, including Psum, Qsum, Ssum, PFavg.
- Summary-6: Specify loop of summary the measurement parameters, including VLLavg, lavg, Psum, PFavg.
- Summary-P: Specify loop of summary the measurement parameters, the parameters to be displayed on this page can be set by yourself.

#### 4.1.1.2 Metering Search

Press ENTER key enter the system menu and select the Metering then press ENTER key again to enter.

Press LEFT key return to previous page.

- First select the loop you want to search, including main loop A, main loop B, loop A 1-3, loop A 4-6, loop A 7-9, loop A 10-12, loop B 1-3, loop B 4-6, loop B 7-9, loop B 10-12.
- V L-N Measurement: Parameter of phase voltage measured by the power meter, including V1, V2, V3, Vavg.
- V L-L Measurement: Parameter of line voltage measured by the power meter, including U12, U23, U31, Uavg.
- Current Measurement: Parameter of current measured by the power meter, including I1, I2, I3, lavg, IN.
- Frequency Measurement
- Power Factor Measurement: Parameter of power factor measured by the power meter, including PF1, PF2, PF3, PFavg.
- Disp.PF Measurement: Parameter of power factor measured by the power meter, including PF1, DPF2, DPF3, DPFavg.

- Unbalance Measurement: Parameter of unbalance measured by the power meter, including U, I.
- Active Power Measurement: Parameter of active power measured by the power meter, including P1, P2, P3, Psum.
- Reactive Power Measurement: Parameter of reactive power measured by the power meter, including Q1, Q2, Q3, Qsum.
- Apparent Power Measurement: Parameter of apparent power measured by the power meter, including S1, S2, S3, Ssum.
  - ※ In the power measurement parameter page, due to display needs, the power unit will automatically change, such as W / VAR / VA, kW / kVAR / kVA or MW / MVAR / MVA.
- Total Harmonic Measurement: There are two types of THD measurement parameters, divided into THD-F and THD-R including V1, V2, V3, Vavg, I1, I2, I3, Iavg.
- Individual Harmonic Measurement: 31 harmonic distortion rate measurement parameters, including V1, V2, V3, I1, I2, I3.
  - ※ Press UP or DOWN key to switch the percentage display values for each sub-harmonic.
  - ※ Press the LEFT key to switch the percentage value of the sub-harmonics to display the scale.
  - ※ Press ENTER key can switch data source: V1, V2, V3, I1, I2, I3.
  - ※ Press LEFT key for 2 sec can leave column chart page of sub-harmonic and return previous page.
- Demand Measurement: Parameter of demand measured by the power meter, including P, Q, S, I1, I2, I3, Iavg.
- MAX/MIN parameters including Phase Voltage, Line Voltage, Current, Power, Frequency, Power Factor, THD-F of Voltage, THD-F of Current, Power Demand, Current Demand.
  - ※ In the MAN/MIN parameters page, press UP key for 2 sec to switch the parameters on the same page, and the time stamp of the parameter will be displayed at the bottom of the screen.
  - ※ In the MAX/MIN parameters page, press the DOWN key for 2 sec to switch to display the MAX or MIN value.

#### 4.1.1.3 Power Parameter Search

Press ENTER key enter the system menu and select the Metering then press ENTER key again to enter.

Press LEFT key return to previous page, some pages need to press LEFT key for 2 sec to return to the previous page.

- First select the loop you want to search, including main loop A, main loop B, loop A 1-3, loop A 4-6, loop A 7-9, loop A 10-12, loop B 1-3, loop B 4-6, loop B 7-9, loop B 10-12,

loop A 1, loop A 2, loop A 3, loop A 4, loop A 5, loop A 6, loop A 7, loop A 8, loop A 9, loop A 10, loop A 11, loop A 12, loop B 1, loop B 2, loop B 3, loop B 4, loop B 5, loop B 6, loop B 7, loop B 8, loop B 9, loop B 10, loop B 11, loop B 12.

- Active Energy Measurement: Active energy measured by the power meter, including active energy import (IMP), output active energy (EXP), total active energy (TOT), active energy net(NET).
- Reactive Energy Measurement: reactive energy measured by the power meter, including input reactive energy (IMP), output reactive energy (EXP), total reactive energy (TOT), reactive energy net(NET).
- Total Apparent Energy Measurement: total apparent energy (TOT).

#### 4.1.1.4 Alarm Search

Press ENTER key enter the system menu and select the Alarm then press ENTER key to enter. Press LEFT key return to previous page.

- First select the alarm you want to search, including Relay 1, Relay 2, Relay 3, and Relay 4.
- Alarm measured by the power meter, including Source, Loop, Object, Value, Set-Point, Mode.

#### 4.1.2 Data Clear & Reset

Press ENTER key enter the system menu and select Clear & Reset then press ENTER key to enter.

Press LEFT key return to previous page.

- Type password: The user of the power meter operates the password lock. The factory value is 1000.
- First select the loop to clear including all loops, main loop A, main loop B, loop A 1-3, loop A 4-6, loop A 7-9, loop A 10-12, loop B 1-3, loop B 4-6, loop B 7-9, loop B 10-12, loop A 1, loop A 2, loop A 3, loop A 4, loop A 5, loop A 6, loop A 7, loop A 8, loop A 9, loop A 10, loop A 11, loop A 12, loop B 1, loop B 2, loop B 3, loop B 4, loop B 5, loop B 6, loop B 7, loop B 8, loop B 9, loop B 10, loop B 11, loop B 12
- Select the parameter you want to clear, which contains: All recorded values, but does not contain MAX demand values, all energy value, all demand value, all maximum demand value, all MAX/MIN value, active energy, reactive energy, apparent energy, current demand, active power demand, reactive power demand, apparent power demand, max current demand, max active power demand, max reactive power demand, max apparent power demand.
- Press the ENTER key to enter the confirmation page, then press the UP or DOWN key to select Yes, and then press the ENTER key to complete the data clearing

### 4.1.3 Power Meter Info Search

Press ENTER key enter the system menu and select Information then press ENTER key to enter.

Press LEFT key return to previous page.

- Power Loop including: Power phase, PT Primary/Secondary value, CT Primary/Secondary value, energy unit, branch loop voltage assign. Depending on the attributes of the main loop and the sub-loop, the displayed content is different.
- Communication including: COM1, COM2, other communication interface.
- Meter Information including: Device , Sub-A Loop, Sub-B Loop

### 4.1.4 USER PASSWORD

- When entering the parameters settings or clear & reset the pages both need to enter password. The factory value is 1000.
- Steps of setup are as follows:
  1. Press UP or DOWN key to select the first digit of the user password.
  2. Press LEFT key, move to the next digit of the user password.
  3. Repeat step 1 to 2 until finishing the 4-digit of the user password.
  4. After entering the 4th digit of the user password, press ENTER key to enter meter parameter setting.
- ※ If type error, the number can be re-entered after 4 zeros.
- ※ If you need to exit the user password page, press and hold the LEFT key for 2 seconds back to default page.

### 4.1.5 General

#### 4.1.5.1 Wire System

- Power System : The wire system can be selected with single-phase two-wire (1P2W), single-phase three-wire (1P3W), three-phase three-wire 1CT (3P3W1CT), three-phase three-wire 2CT (3P3W2CT), three-phase three-wire 3CT (3P3W3CT), three-phase four-wire 1CT (3P4W1CT), three-phase Four-wire 3CT (3P4W3CT), The factory value is three-phase four-wire 3CT (3P4W3CT),
- Steps of setup are as follows:
  1. Press ENTER key on the menu page to enter wire system setting.
  2. Press UP or DOWN key to select the loop to be set and press ENTER to enter.
  3. Press UP or DOWN to select the wire system method.
  4. Press ENTER key to finish setting and return to the previous menu.
- ※ Press LEFT key to cancel the setting and return to the previous menu.

- ※ Each group of loops can independently set the phase-line system for measurement, but there will be restrictions based on the voltage phase-line system connected to the main loop, see the table below:

Voltage phase/line input	Sub loop set up			
	1P2W	1P3W	3P3W	3P4W
1P2W	○	X	X	X
1P3W	○	○	X	X
3P3W	○	X	○	X
3P4W	○	X	○	○

#### 4.1.5.2 Voltage Transformer Setting

- PT Primary: The setting range for the volt of PT primary side is 0~9999k V. The default value is 600 V.
- PT Secondary: The setting range for the volt of PT primary side is 50~600 V. The default value is 600 V.
- Steps of setup are as follows:
  1. Press ENTER key on the menu page to enter the volt of PT primary setting.
  2. Press UP or DOWN key to select and set the voltage value of loop A or loop B or the voltage unit of the PT primary, and press the ENTER key to enter.
  3. Press UP or DOWN key to select the numeric.
  4. Press LEFT key to move to the next digit.
  5. Repeat step 3 to 4 until finishing volt setting, press ENTER key to save and return to the previous menu.
  6. Press ENTER key to enter the voltage unit setting.
  7. Press UP or DOWN key to select the unit V or kV.
  8. Press ENTER key to save and return to the menu.
  9. The volt setting of PT secondary is the same as PT primary.
- ※ Press LEFT key to cancel input and return to the previous menu.

#### 4.1.5.3 Current Transformer Setting

- CT Primary: The setting range of Ampere of CT primary side is 5~9999 A. The default value is 5 A.
- CT Secondary: The setting range of Ampere of CT primary side is 1 A or 5 A. The default value is 5 A.
- Steps of setup are as follows:
  1. Press ENTER key on the menu page to enter the CT primary.
  2. Press UP or DOWN key to select the loop to be set, press ENTER key to enter.
  3. Press UP or DOWN key to select the numeric.
  4. Press LEFT key move to the next digit.
  5. Repeat step 3 to 4 until finishing ampere setting, press ENTER key to save and return to the previous menu.

6. Press ENTER key to enter the CT secondary. This setting is only available for the main loop.
  7. Press UP or DOWN to select the ampere.
  8. Press ENTER key to finish setting and return to the previous menu.
- ※ Press LEFT key to cancel input and return to the previous menu.

#### 4.1.5.4 Branch Loop Voltage Phase Assign

- The voltage phase of each branch loop can be specified according to the actual CT mounting conditions and measurement needs to obtain the required power measurement data.
  - Steps of setup are as follows:
    1. Press ENTER key on the menu page to enter voltage assign setting.
    2. Press UP or DOWN key to select the loop to be set, press ENTER key to enter.
    3. Press UP or DOWN key to select the corresponding voltage phase of the loop.
    4. Press ENTER key to finish setting and return to the previous menu.
- ※ Press LEFT key to cancel input and return to the previous menu.

#### 4.1.5.5 Modify Password

- Change user password, the default value is 1000.
  - Steps of setup are as follows:
    1. Press ENTER key on the menu page to enter password setting.
    2. Press UP or DOWN key to select the numeric.
    3. Press LEFT key move to the next digit.
    4. Repeat step 2 to 3 until finishing 4-digits, press ENTER key to save and return to the previous menu.
- ※ Press LEFT key and hold 2 seconds to cancel input and return to the previous menu.

#### 4.1.5.6 Default Page

- Default Page : On the default page of the meter, optional Summary-1(VLLavg/lavg/Psum/Freq), Summary-2(sum/Qsum/Ssum/PFavg), Summary-3(VLLavg/lavg/Psum/PFavg), Summary-4/5/6 and Summary-1/2/3 are the same parameter. Summary 1-6 both can select the corresponding circuit individually. Summary-P is a user-defined page, and the corresponding loop and parameter items can be set by yourself. In addition, all the default page can be set to display one by one.
- Steps of setup are as follows:
  1. Press ENTER key on the menu page to enter default page setting.
  2. Press UP or DOWN key to select the page to be set.
  3. Press ENTER key to finish setting and return to the previous menu.
  4. Press ENTER key to enter specify loop setting.
  5. Press UP or DOWN key to select the default page to be set, press ENTER key to enter.

6. Press UP or DOWN key to select the corresponding circuit of the circuit.
  7. Press ENTER key to finish setting and return to the previous menu.
  8. Press ENTER key to enter user-defined page setting.
  9. Press UP or DOWN key to select the parameter position to be set, press ENTER key to enter.
  10. Press UP or DOWN key to select the parameter to be displayed at that position.
  11. Press ENTER key to finish setting and return to the previous menu.
  12. Press ENTER key to enter screen rotation time setting.
  13. Press LEFT key and move on to the next digit.
  14. Press LEFT key move to next digit of second time.
  15. Repeat step 13 finishing second time setting, press ENTER key to save and return to the menu.
- ※ Press LEFT key for 2 seconds to cancel the changes and return to the previous menu.

#### 4.1.5.7 Current Low-cut

- Current low-cut setting. The setting range is 0.009 ~ 59.999A. The default value is 0.009A.
  - Steps of setup are as follows:
    1. Press ENTER key on the menu page to enter current low-cut setting.
    2. Press UP or DOWN key to select the loop to be set, press ENTER key to enter.
    3. Press UP or DOWN key to select the numeric.
    4. Press LEFT key move to the next digit.
    5. Repeat step 3 to 4 until finishing 5-digit setting of current low-cut, press ENTER key to save and return to the previous menu.
- ※ Press LEFT key and hold 2 seconds to cancel input and return to the previous menu.

## 4.1.6 Communcion

Firstly, select the port to be set, including COM1, COM2.

### 4.1.6.1 Address

- Power meter device address setting. The selectable range is 1~247. Broadcast is 255. The factory value is 1.
- Steps of setup are as follows:
  1. Press ENTER key on the menu page to enter address setting.
  2. Press UP or DOWN key to select the address.
  3. Press LEFT key and move on to the next digit.
  4. Repeat step 2 to 3 until finishing 3-digit setting of communication device address, press ENTER key to save and return to the menu.
- ※ Press LEFT key for 2 seconds to cancel the setting and return to the previous menu.

### 4.1.6.2 Baudrate

- Baud rate setting. The selectable range is 1200 、 2400 、 4800 、 9600 、 19200 、 38400 、 57600 、 115200 bps. The factory value is 9600 bps.
- Steps of setup are as follows:
  1. Press ENTER key on the menu page to enter baud rate.
  2. Use UP and DOWN key to select required baud rate.
  3. Press ENTER key to finish setting and return to the menu.
- ※ Press LEFT key to cancel the setting and return to the previous menu.

#### 4.1.6.3 Parity

- Communication parity check bit setting. The selectable range is N.8.1、N.8.2、O.8.1、E.8.1. The factory value is N.8.2.
- Steps of setup are as follows:
  1. Press ENTER key on the menu page to enter parity setting.
  2. Use UP and DOWN key to select required parity setting.
  3. Press ENTER key to finish setting and return to menu.
- ※ Press LEFT key to cancel the setting and return to the previous menu.

Select the communication module to set the second set of communication interface parameters.

#### 4.1.6.4 IP Address

- When the second group of communication interface is Ethernet, the parameters that can be set are DHCP, IP address, sub-mask address and way address. The communication protocol is Modbus TCP.
- The default IP address is 192.168.1.250, and DHCP is preset to automatic mode.
- Steps of setup are as follows:
  1. Press ENTER key on the menu page to enter DHCP setting.
  2. Use UP and DOWN key to select enable or disable.
  3. Press ENTER key to finish setting and return to the previous menu.
  4. Press ENTER key to enter IP Address setting.
  5. Press UP or DOWN key to select the IP Address number.
  6. Press LEFT key move to the next digit.
  7. Repeat step 5 to 6 until finishing IP Address 12 digit, press ENTER key to save and return to the previous menu.
  8. Press ENTER key to enter the Subnet Mask setting.
  9. The Subnet Mask address setting method is the same as the IP address.
  10. Press ENTER to enter the Default Gateway setting.
  11. Gateway address setting method is the same as the IP address.
- ※ Press LEFT key and hold 2 seconds to cancel input and return to the previous menu.

#### 4.1.6.5 Module Control

- The control function of the communication module can restart the communication module or restore the set related parameters to the factory default values.
- After the Ethernet parameters are changed, the module must be restarted to take effect.
- Steps of setup are as follows:
  1. Press ENTER key on the menu page to enter Force Reboot.
  2. Use UP and DOWN key to select Yes or No.
  3. Press ENTER key to finish setting and return to the previous menu.
  4. Press ENETER key to enter Set to Default setting.
  5. Use UP and DOWN key to select Yes or No.
  6. Press ENTER key to finish setting and return to the previous menu.
- ※ Press LEFT key to cancel the changes and return to the previous menu.

#### 4.1.7 Pulse Output

##### 4.1.7.1 Test Pulse

- Set the test pulse output function is enabled or disabled because the default value is disabled. The pulse output is fixed at 3200 Pulse / 1kWh, and the duty cycle is 50%.
- Steps of setup are as follows:
  1. Press ENTER key on the menu page to enter test pulse setting.
  2. Use UP and DOWN key to select enable or disable.
  3. Press ENTER key to finish setting and return to the previous menu.
- ※ Press LEFT key to cancel input and return to the previous menu.

##### 4.1.7.2 Target Loop

- Select the loop corresponding to the pulse output. The default value is main loop A.
- Steps of setup are as follows:
  1. Press ENTER key on the menu page to enter target loop setting.
  2. Use UP and DOWN key to select the corresponding loop.
  3. Press ENTER key to finish setting and return to the previous menu.
- ※ Press LEFT key to cancel input and return to the previous menu.

#### 4.1.7.3 Energy Type

- Select the corresponding energy parameters for pulse output. The selectable parameters include Import kWh, Export kWh, Import kVARh, Export kVARh, and can also be OFF. The default value is Import kWh.
- Steps of setup are as follows:
  1. Press ENTER key on the menu page to enter energy type setting.
  2. Use UP and DOWN key to select the corresponding energy parameter.
  3. Press ENTER key to finish setting and return to the previous menu.
- ※ Press LEFT key to cancel input and return to the previous menu.

#### 4.1.7.4 Pre-Divider

- Pre-Divider setting. The setting range is 1 ~ 9999 , The default value is 1.
- Steps of setup are as follows:
  1. Press ENTER key on the menu page to enter pre-divider setting.
  2. Press UP or DOWN key to select the numeric.
  3. Press LEFT key move to the next digit.
  4. Repeat step 2 to 3 until finishing 4-digit setting of pre-divider, press ENTER key to save and return to the previous menu.
- ※ Press LEFT key and hold 2 seconds to cancel input and return to the previous menu.

#### 4.1.7.5 High Time

- Pulse output high level time setting, the setting range is 0 ~ 5000 mS, 0 means 50% duty of the high and low level. The default value is 0.
- Steps of setup are as follows:
  1. Press ENTER key on the menu page to enter high time setting.
  2. Press UP or DOWN key to select the numeric.
  3. Press LEFT key move to the next digit.
  4. Repeat step 2 to 3 until finishing 4-digit setting of high time, press ENTER key to save and return to the previous menu.
- ※ Press LEFT key and hold 2 seconds to cancel input and return to the previous menu.

#### 4.1.8 Energy Unit

- Energy unit setting, the unit that can be selected are 0.0001kWh 、 0.001kWh 、 0.01kWh 、 0.1kWh 、 1kWh 、 0.01MWh 、 0.1MWh. The default value is 0.1kWh.
- Steps of setup are as follows:
  1. Press ENTER key on the menu page to enter energy unit setting.
  2. Use UP or DOWN key to select energy unit.
  3. Press ENTER key to finish setting and return to the previous menu.
- ※ Press LEFT key to cancel input and return to the previous menu.

## 4.1.9 Date/Time

### 4.1.9.1 Backlight Time

- LCM backlight time setting. The setting range is 0 ~ 15 minutes, 0 means the light stays always on. The default value is 1.
- Steps of setup are as follows:
  1. Press ENTER key on the menu page to enter the backlight time setting.
  2. Press UP or DOWN key to select the numeric.
  3. Press LEFT key move to the next digit.
  4. Repeat step 2 to 3 until finishing 2-digit setting of time, press ENTER key to save and return to the previous menu.
- ※ Press LEFT key and hold 2 seconds to cancel input and return to the previous menu.

### 4.1.9.2 Date

- Date setting. The setting range is 2010/1/1 ~ 2099/12/31.
- Steps of setup are as follows:
  1. Press ENTER key on the menu page to enter the date setting.
  2. Press UP or DOWN key to select the numeric.
  3. Press LEFT key move to the next digit.
  4. Repeat step 2 to 3 until finishing 8-digits setting of date, press ENTER key to save and return to the previous menu.
- ※ Press LEFT key and hold 2 seconds to cancel input and return to the previous menu.

### 4.1.9.3 Time

- Time setting. The selectable range is 00: 00: 00 ~ 23: 59: 59.
- Steps of setup are as follows:
  1. Press ENTER key on the menu page to enter the time setting.
  2. Press UP or DOWN key to select the numeric.
  3. Press LEFT key move to the next digit.
  4. Repeat step 2 to 3 until finishing 6-digits setting of time, press ENTER key to save and return to the previous menu.
- ※ Press LEFT key and hold 2 seconds to cancel input and return to the previous menu.

### 4.1.9.4 Operation Hour Reset

- Reset the operation hour.
- Steps of setup are as follows:
  1. Press ENTER key on the menu page to enter operation hour reset setting.
  2. Use UP and DOWN key to select “YES” for clear or “NO” for leave.
  3. Press ENTER key to finish setting and return to the previous menu..
- ※ Press LEFT key to cancel input and return to the previous menu.
- ※ The operation hour starts accumulating after the meter starts running.

#### 4.1.9.5 Running Hour Reset

- Reset the running hour.
- Steps of setup are as follows:
  1. Press ENTER key on the menu page to enter running hour reset setting.
  2. Use UP and DOWN key to select “YES” for clear or “NO” for leave.
  3. Press ENTER key to finish setting and return to the previous menu.
- ※ Press LEFT key to cancel input and return to the previous menu.
- ※ The running hour starts accumulating when the current input value exceeds 1% of the rated value.

#### 4.1.10 Demand

##### 4.1.10.1 Mode

- Demand calculation mode setting. The selectable mode are sliding block, fixed block, The default value is sliding block.
- Steps of setup are as follows:
  1. Press ENTER key on the menu page to enter demand mode setting.
  2. Use UP and DOWN key to select demand mode.
  3. Press ENTER key to finish setting and return to the previous menu.
- ※ Press LEFT key to cancel input and return to the previous menu.

##### 4.1.10.2 Period

- Calculation period time setting. The setting range is 1 ~ 60 minutes. The default value is 15 minutes.
- Steps of setup are as follows:
  1. Press ENTER key on the menu page to enter period setting.
  2. Press UP or DOWN key to select the numeric.
  3. Press LEFT key move to the next digit.
  4. Repeat step 2 to 3 until finishing 2-digits setting of period time, press ENTER key to save and return to the previous menu.
- ※ Press LEFT key and hold 2 seconds to cancel input and return to the previous menu.

#### 4.1.11 Input/Output

##### 4.1.11.1 Digital Input

- The meter has two digital input uncluding DI1, DI2.
- In addition to being Digital Input, the functions of the digital input port can also be set up as: Demand Reset, MAX Demand Reset, Energy Reset, MAX/MIN Reset, Relay Reset. The default value is DI.
- Trigger level can be set to ON or OFF.
- The input debounce time can be set. To avoid misoperation, the set range is 0~99 (x

8mS), and the default value is 5, which is 40mS.

- Both digital input ports can be set in the same way as the function parameters.
- Steps of setup are as follows:
  1. Press ENTER key on the menu page to enter function mode setting.
  2. Press UP and DOWN key to select function mode.
  3. Press ENTER key to finish setting and return to the previous menu.
  4. Press ENTER key to enter trigger state setting.
  5. Use UP or DOWN key to select ON or OFF.
  6. Press ENTER key to finish setting and return to the previous menu.
  7. Press ENTER key to enter debounce time setting.
  8. Press UP or DOWN key to select the numeric.
  9. Press LEFT key move to the next digit.
  10. Repeat step 8 to 9 until finishing 2-digits setting of debounce time, press ENTER key to save and return to the previous menu.
- ※ Press LEFT key and hold 2 seconds to cancel input and return to the previous menu.

#### 4.1.11.2 Relay Output

- The meter has four relay output ports including RO1, RO2, RO3, RO4.
- In addition to being Relay Output, the function of the relay output port can also be set for alarm mode, and the default value is Relay Output.
- In alarm mode, the relay Active Delay Time can be set, the range is 0~5999 (x 0.1S), and the default value is 0.
- The alarm conditions for each set of relay output ports can be set in 12 groups, including: Alarm Mode, Loop, Object, Set Point.
- The alarm action modes for relays include: Low, High, Low and Hold, High and Hold, and Off. When set to action and hold mode, the DI needs to be set as a relay reset function so that the relay can be reset through the DI input.
- The alarm corresponding parameters of the relay includes Frequency, Phase Vavg, Line Vavg, Current, Active Power, Reactive Power, Apparent Power, Power Factor, Demand Current, Demand Power P, Demand Power Q, Demand Power S.
- The four sets of relay output ports can be set in the same way as the function parameters.
- Steps of setup are as follows:
  1. Press ENTER key on the menu page to enter function mode setting.
  2. Press UP and DOWN key to select function mode.
  3. Press ENTER key to finish setting and return to the previous menu.
  4. Press ENTER key to enter active delay time setting.
  5. Press UP or DOWN key to select the numeric.
  6. Press LEFT key move to the next digit.
  7. Repeat step 5 to 6 until finishing 4-digits setting of active delay time, press ENTER key to save and return to the previous menu.

8. Press ENTER key on the menu page to enter alarm set setting
  9. Press UP or DOWN key to select the alarm condition group.
  10. Press ENTER key to enter alarm conditional setting.
  11. Press ENTER key to enter alarm mode setting.
  12. Press UP and DOWN key to select alarm mode.
  13. Press ENTER key to finish setting and return to the previous menu.
  14. Press ENTER key to select loop setting.
  15. Press UP and DOWN key to select the loop.
  16. Press ENTER key to finish setting and return to the previous menu.
  17. Press ENTER key to enter object setting.
  18. Press UP and DOWN key to select parameter.
  19. Press ENTER key to finish setting and return to the previous menu.
  20. Press ENTER key to enter set point setting.
  21. Press UP or DOWN key to select the numeric.
  22. Press LEFT key move to the next digit.
  23. Repeat step 21 to 22 until finishing all digit setting of set point, press ENTER key to save and return to the previous menu.
- ※ Press LEFT key and hold 2 seconds to cancel input and return to the previous menu.

#### 4.1.12 Initial

- Recover the power meter to factory default value. The default password is 7170.
- Steps of setup are as follows:
  1. Press ENTER key on the menu page to enter initial setting.
  2. Press UP or DOWN key to select the numeric.
  3. Press LEFT key move to the next digit.
  4. Repeat step 2 to 3 until finishing 4-digit setting of password, press ENTER key confirm initial and return to the previous menu.
- ※ Press LEFT key and hold 2 seconds to cancel input and return to the previous menu.
- ※ The meter will restart when initial starts operating.

## 4.2 Measurement algorithm

### 4.2.1 Harmonic

Total Harmonic Distortion (THD) is the current detection of waveform distortion. The calculation method is divided into fundamental wave and true RMS value, which is the ratio of harmonic content to fundamental wave or true RMS value. The calculation formula of voltage/current total harmonic distortion is:

Fundamental (THD-F):

Current Total Harmonic Distortion:	$THD_I = \frac{1}{ I_{fund} } \sqrt{\sum_{n=2}^{31}  I_{n.Harm} ^2}$
Voltage Total Harmonic Distortion:	$THD_U = \frac{1}{ U_{fund} } \sqrt{\sum_{n=2}^{31}  U_{n.Harm} ^2}$

Ture RMS(THD-R):

Current Total Harmonic Distortion:	$THD_I = \frac{1}{\sqrt{\sum_{n=1}^{31}  I_{n.Harm} ^2}} \sqrt{\sum_{n=2}^{31}  I_{n.Harm} ^2}$
Voltage Total Harmonic Distortion:	$THD_U = \frac{1}{\sqrt{\sum_{n=1}^{31}  U_{n.Harm} ^2}} \sqrt{\sum_{n=2}^{31}  U_{n.Harm} ^2}$

### 4.2.2 Demand

This meter is consist of several types of demand calculation: active power demand, reactive power demand, apparent power demand, three phase current demand and average current demand. The calculation method is as follows:

#### 4.2.2.1 Sliding Block

When using the sliding block interval method, user selects an interval from 1 to 60 minutes, which is the period of the calculation. The demand updates every 1 minute as the block slides once. The following example is a figure for 15-minute block interval:

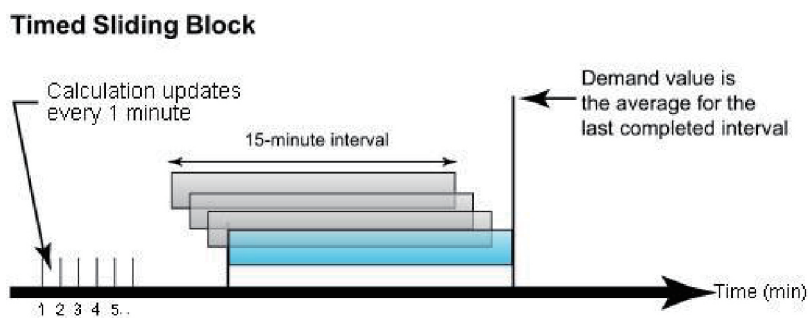

#### 4.2.2.2 Fix Block

Like the sliding block, a calculation period is set first, and the increment is also one minute. However, only one demand is calculated in the whole period. So the interval of the demand update is the calculation of the cycle time. The following example is a figure for 15-minute block interval:

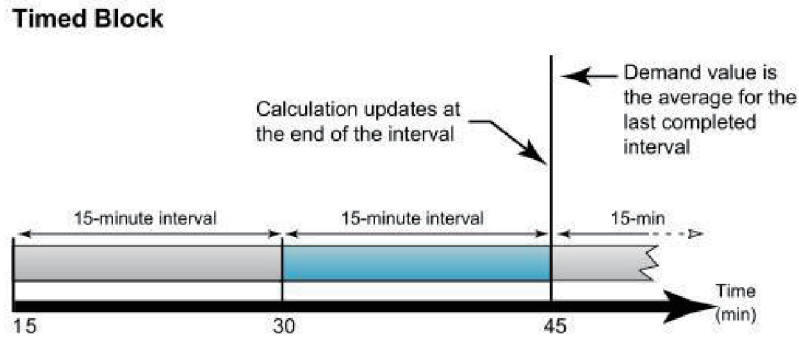

### 4.3 Block transfer function

This function is mainly about allowing the user to gather all the parameter values and read them at one time.

Fill in the address of the parameter with 0x5000~0x504F in sequence, and then you can read the value of the corresponding parameter from the address of 0x5100~0x514F.

Please refer to the setting range marked in the communication address table for the address range that can be set.

For example:

When 0x5000 is written to 0x1001 (high byte address of V1 voltage of main loop A), 0x5001 is written to 0x1002 (low byte address of V1 voltage of main loop A), the value obtained by reading 0x5100 and 0x5101 is the V1 voltage value of main loop A, and so on.

### 4.4 Data Logging function

In order to help users understand the history of the meter, the meter provides data logging function.

Record a set of data at regular intervals. Meter is equipped with data storage capacity of 2MB for data recording. The meter has a real-time clock and each data log will be recorded.

#### 4.4.1 Data logging function setting

According to users requirement, the data logging function can set up to 86 parameters. There are 86 parameters can be recorded, see Table 4-1.

Table 4-1

No.	Parameter	No.	Parameter	No.	Parameter	No.	Parameter	No.	Parameter
0	NONE	1	Main Loop A Frequency	2	Main Loop A Phase voltage average	3	Main Loop A Line voltage average	4	Main Loop A Current average
5	Main Loop A Total active power	6	Main Loop A Total reactive power	7	Main Loop A Total apparent power	8	Main Loop A Power factor average	9	Main Loop A Import active energy
10	Main Loop A Import reactive energy	11	Main Loop A Import apparent energy	12	Branch Loop A1-3 Current	13	Branch Loop A1-3 Active power	14	Branch Loop A1-3 Reactive power
15	Branch Loop A1-3 Apparent power	16	Branch Loop A1-3 Power factor	17	Branch Loop A1-3 Import active energy	18	Branch Loop A1-3 Import reactive energy	19	Branch Loop A1-3 Apparent energy
20	Branch Loop A4-6 Current	21	Branch Loop A4-6 Active power	22	Branch Loop A4-6 Reactive power	23	Branch Loop A4-6 Apparent power	24	Branch Loop A4-6 Power factor
25	Branch Loop A4-6 Import active energy	26	Branch Loop A4-6 Import reactive energy	27	Branch Loop A4-6 Apparent energy	28	Branch Loop A7-9 Current	29	Branch Loop A7-9 Active power
30	Branch Loop A7-9 Reactive power	31	Branch Loop A7-9 Apparent power	32	Branch Loop A7-9 Power factor	33	Branch Loop A7-9 Import active energy	34	Branch Loop A7-9 Import reactive energy
35	Branch Loop A7-9 Apparent energy	36	Branch Loop A10-12 Current	37	Branch Loop A10-12 Active power	38	Branch Loop A10-12 Reactive power	39	Branch Loop A10-12 Apparent power

40	Branch Loop A10-12 Power factor	41	Branch Loop A10-12 Import active energy	42	Branch Loop A10-12 Import reactive energy	43	Branch Loop A10-12 Apparent energy	44	Main Loop B Frequency
45	Min Loop B phase voltage average	46	Main Loop B Line voltage	47	Main Loop B Current average	48	Main Loop B Total active power	49	Main Loop B Total reactive power
50	Main Loop B Total apparent power	51	Main Loop B Power factor average	52	Main Loop B Import active energy	53	Main Loop B Import reactive energy	54	Main Loop B Import apparent energy
55	Branch Loop B1-3 Current	56	Branch Loop B1-3 Active power	57	Branch Loop B1-3 Reactive power	58	Branch Loop B1-3 Apparent power	59	Branch Loop B1-3 Power factor
60	Branch Loop B1-3 Import active energy	61	Branch Loop B1-3 Import reactive energy	62	Branch Loop B1-3 Apparent energy	63	Branch Loop B4-6 Current	64	Branch Loop B4-6 Active power
65	Branch Loop B4-6 Reactive power	66	Branch Loop B4-6 Apparent power	67	Branch Loop B4-6 Power factor	68	Branch Loop B4-6 Import active energy	69	Branch Loop B4-6 Import reactive energy
70	Branch Loop B4-6 Apparent energy	71	Branch Loop B7-9 Current	72	Branch Loop B7-9 Active power	73	Branch Loop B7-9 Reactive power	74	Branch Loop B7-9 Apparent power
75	Branch Loop B7-9 Power factor	76	Branch Loop B7-9 Import active energy	77	Branch Loop B7-9 Import reactive energy	78	Branch Loop B7-9 Apparent energy	79	Branch Loop B10-12 Current
80	Branch Loop B10-12 Active power	81	Branch Loop B10-12 Reactive power	82	Branch Loop B10-12 Apparent power	83	Branch Loop B10-12 Power factor	84	Branch Loop B10-12 Import active energy
85	Branch Loop B10-12 Import reactive energy	86	Branch Loop B10-12 Apparent energy						

The time parameters required for the data logging function are shown as Table 4-2  
Table 4-2

Hex	Item	Size	Data Format	Range	Unit	Default	R / W	Notes
0x4010	FLASH remaining time	1	INT16U	0~65535			R / W	
0x4011	Logging interval time	1	INT16U	1~32767		15	R / W	
0x4012	Unit of interval time	1	INT16U	0: sec 1: min 2: hour 3: day		1	R / W	
0x4013	Date and time for start	1	INT16U	2020~2099	Year		R / W	
0x4014		1	INT16U	1~23	Month		R / W	
0x4015		1	INT16U	1~31	Day		R / W	
0x4016		1	INT16U	0~23	Hour		R / W	
0x4017		1	INT16U	0~59	Minute		R / W	
0x4018		1	INT16U	00~59	Second		R / W	
0x4019		Date and time for stop	1	INT16U	2020~2099	Year		R / W
0x401A	1		INT16U	1~23	Month		R / W	
0x401B	1		INT16U	1~31	Day		R / W	
0x401C	1		INT16U	0~23	Hour		R / W	
0x401D	1		INT16U	0~59	Minute		R / W	
0x401E	1		INT16U	00~59	Second		R / W	
0x401F	Logging enable		1	INT16U	0: Disable 1: Enable			R / W
0x4020	Log.01	1	INT16U	See table 4-1		0	R / W	
0x4021	Log.02	1	INT16U	See table 4-1		0	R / W	
:	:							
0x4074	Log.85	1	INT16U	See table 4-1		0	R / W	
0x4075	Log.86	1	INT16U	See table 4-1		0	R / W	

FLASH remaining time: The remaining time until the data memory is full, the unit of reading is minutes.

Recording interval duration time: Can set any integer between 1 ~ 32767. Unit with the interval time, that is each data record interval time.

Record interval duration time unit: Can set the second, minute, hour, day.

Record period: Enable the data logging function to set the start time and end time. The time setting range is year, month, day, hour, minute and second. When enabled, a data log is recorded for each record interval duration time between the start time and the end time.

Note: Condition setting, recording function enable, etc. must be done before using the data logging function. Any incomplete or incorrect settings will result in the recorded failure. The setting operation is completed by setting the corresponding register. It should be specially explained that the settings of these registers must be set by means of communication. once the record capacity is full, data will be based on first-in-first-out principle of circular coverage. When cyclic overwriting occurs, the earliest recorded data will be overwritten sequentially. Therefore, user are advised to read and save the entire data record before it is full to prevent data loss.

When the contents of the record parameters have been changed, then all the records will not be reserved.

be retained and start recording from beginning.

#### 4.4.2 Data log read

Read data logs must go through communication, see Table 4-3.

Table 4-3

Hex	Item	Size	Data Format	Range	Unit	Default	R / W	Notes
0x4000	Byte count of each recording	1	INT16U	1~255			R	
0x4001	Number of unread data	1	INT16U	0~65535			R	
0x4002	Data read	1	INT16U	Reply 0x20 if data empty			R	
0x4003	Status reply after read	1	INT16U	0: Clear logging data (Index reset) 1: Abort this time read (Index will not any shift) 2: Read success			W	

The length of each data record can be obtained by reading the length address (0x4000) of each record. The data length obtained is read through the data reading address (0x4002), shown as below :

Request:

Address	Code	Starting Reg		Byte count		CRC	
		Hi	Lo	Hi	Lo	LO	Hi
01h	03h	40h	00h	xxh	xxh	xxh	xxh

Byte count: Read from 0x4000

The data content will be returned as below:

Response:

Address	Code	Byte Count	Year		Month		Day		Hour		Minute		Second		Data	CRC	
			Hi	Lo	Hi	Lo	Hi	Lo	Hi	Lo	Hi	Lo	Hi	Lo		Lo	Hi
01h	03h	30h	07h	DFh	00h	0Ch	00h	01h	00h	0Dh	00h	19h	00h	2Ah	.....	xxh	xxh

Byte Count: Read from 4000h

Date: 2015/12/01 (07DFH/000CH/001H)

Time: 13:25:42 (000DH:0019H:003AH)

Each read order can only read a log record. Reading unread number(0x4001) shows how many logs remain unread. If there is no record that has not been read yet, then the data return will be 0020h, indicating that the data record has been read.

After reading a record of log must be send back the read status(0x4003) to meter, as a basis for recording indicators move. Can also give up the record read or clear data records via send back the read status.

## 4.5 Time of use (TOU) Function

User can assign up to 4 different tariffs (sharp, peak, valley and normal) to different time period within a day according to the billing requirements. The meter will calculate and accumulate energy to different tariffs according to the meter' s internal clock timing and TOU settings.

TOU setting: User can set a maximum of 4 TOU seasons, each season can be assigned to a TOU schedule, maximum of 8 TOU schedules are available. Each schedule can be divided up into 8 segments, each segment can have its own tariff (sharp, peak, valley and normal).

User can customize the TOU calendar (including its tariffs, seasons, schedules and segments) according to different applications. To make sure that the TOU calendar is setup correctly, the meter will check the TOU settings according to the predefined rules.

TOU function will be disabled if the TOU calendar is set up incorrectly. If no errors are found in the calendar and the TOU function is enabled, TOU energy accumulation will begin.

### 4.5.1 Season Setting

The calendar year will be divided up into different seasons depending on the season setting parameter. The parameter can be selected from any integer between 1 to 4. User must enter the correct value for the season setting parameter in accordance to the TOU season table. If the season setting parameter is set as 2, the first 2 slots of the TOU season table must be set, otherwise it will be considered as an invalid input, TOU function will be disabled.

## 4.5.2 TOU Season Format

XX month-XX day, X day timetable, the time zone setting must be done in a closed loop structure, otherwise it will be regarded as an error. For example, three time zones are selected, the first time zone is set to January 1st 1 time slot table, the second time zone is set to June 6th 2 time slot table, and the third time zone is set to September 7th 3 time slot table. If the first time zone is set to January 1st 1 timetable, the second time zone is set to September 7th 2 timetables, and the third time zone is set to June 6th 3 timetables, it will be regarded as an error.

## 4.5.3 Schedule Setting

The setting parameter of the daily timetable is an integer between 1 and 8. After the number of daily timetables is set, the day timetable in the daily timetable will be set in descending order according to the setting parameters of the daily timetable.

The function of the daily timetable is to preset each time zone of the day and the corresponding rate, so up to 8 timetables can be preset for 4 time zones to apply.

## 4.5.4 Segment Setting

The setting parameter of the number of day periods is an integer between 1 and 8, that is, a day can be divided into 8 periods at most. After the setting of the number of time periods of the day is completed, the parameters of the day time period will be set in the daily time period table according to the number of days. The setting format of the daily time slot is XX hour-XX minutes, X rate, and the daily time slot setting is in the order of from small to large. Note that the daily time slot setting must be closed loop production, otherwise it will be regarded as a production error.

## 4.5.5 Tariff Setting

This parameter corresponds to the number of tariffs available for the TOU calendar and can be selected from any integer from 0 to 3. The four tariffs: sharp, peak, valley and normal are represented by 4 integers: 0,1,2 and 3 respectively.

## 4.5.6 Holiday Setting

This parameter can be set from any integer between 0 and 20, meaning a maximum of 20 holidays can be programmed to the TOU calendar. If the holiday setting parameter is set as 3, the first 3 slots of the holiday schedule must be set, otherwise it will be considered as an invalid input, TOU function will be disabled.

Note: User can reset the TOU calendar to default value via communication.

#### 4.5.7 Holiday schedule

The holiday schedule uses the same format as the TOU seasons “MM-DD ID” . User can select which TOU schedule to be used for the holiday. The dates of the holiday schedule do not need to be organized in a sequential order (i.e. the first slot can be January 1, the second slot can be December 26 and the third slot can be December 25).

Holiday day can be set to use the same holiday day setting for the next 5 years, or 5 years holiday day can be setting separately. When multi-year holiday function is enabled, if the current year of the meter falls into the multi-year holiday setting, it automatically loads the multi-year holiday settings into the current TOU settings. If the current year of the meter does not fall into the multi-year holiday setting, it remains the current TOU settings.

Note: Holiday schedule has the highest priority among all the schedules.

#### 4.5.8 Weekend Schedule

Weekend setting: Definition of weekend is fixed as Saturday and Sunday. When the meter clock is within the Weekend Schedule, the energy will accumulate under the tariff that corresponds to the Schedule.

Note: Weekend schedule's priority is followed by Holiday schedule. When Holiday schedule is not enabled, Weekend schedule has the highest priority, overriding the normal (weekday) schedule.

#### 4.5.9 Demand

TOU can record maximum power and current demand under different tariffs, as well as the time stamp of the maximum value. It can also clear by setting the corresponding register or from the meter front.

#### 4.5.10 TOU Settlement

In TOU, the settlement of electric energy can be done in two ways:

Method 1: Settle the electric energy in the way of the end of the natural month, that is, save the electric energy value of the current month to the corresponding space of the electric energy of the previous month at 0:00:00 on the 1st of each month.

Method 2: Settlement of electric energy according to the set day, that is, when the value of XX day XX hour XX minute XX second of the electric meter operation is the same as the set value of the electric meter, the electric energy value of the current month is saved to the corresponding space of the electric energy of the previous month.

# Chapter 5 Message of Abnormal Operations

## 5.1 Common malfunction analysis

### 5.1.1 Power meter doesn't work after it's electrified

- Make sure voltage and other wiring is correct, voltage should be in the future functional range.
- Turn off meter and restart.

### 5.1.2 Voltage or current reading is incorrect

- Check the wiring mode settings match the actual wiring mode.
- Check the voltage potential transformer (PT) and current transformer (CT) variable ratio are set correctly.
- Check the GND is correctly grounded.
- Check the voltage potential transformer (PT) and current transformer (CT) are intact.

### 5.1.3 Power or power factor reading is incorrect, but voltage and current are correct

- Compare the voltage and current input of the inter-wiring and wiring diagram to check whether the phase relationship is correct.

### 5.1.4 RS-485 communication is unusual

- Check the communication baud rate, ID and communication protocol settings of the upper machine are consistent with the meter.
- Please check whether the data bit, stop bit, check bit settings are consistent with the host computer.
- Check if RS-485 converter is working.
- Check whether there is any problem with the entire communication line (short circuit, open circuit, grounding, whether the shield wire is correctly grounded at single-end, etc.).
- Turn off the meter and host computer, and then restart.
- For long communication lines, it is recommended that a matching resistance of about 120 ohms be connected in parallel at the end of the communication line.