

# AEM-DRB Multi-Circuit Power Meter (DIN Rail) **ADTEK**

## Description

Due to climate change and global warming crisis caused by excess carbon dioxide emissions, energy conservation and carbon reduction have always been important issues. In addition, The EU has committed to be carbon neutral by 2050 and decided to proceed carbon border tax. Besides Corporate Social Responsibility (CSR), the companies are facing the impact of the rising cost.

In response to the market trend and customer needs, ADTEK develops AEM-DRB multi-loop power meters using high-performance advanced microprocessors and high-resolution fast sampling AD. It is small, easily installed, multi-functional, and at reasonable price.

AEM-DRB is built with 2 main circuits, and it can proceed the outputs of 24 single phase or 8 three-phase. Different phases can be connected together for the workplace with different electrical circuits to save the cost. In addition, It is equipped with RS485 Modbus communication, input, output interface, LCD display, demand, TOU, data log and 2MB memory capacity. To be more widely available, it can go with the 2nd communication port( optional).



## Features

- DIN Rail mounting and with clamp-on CT measurement achieves space saving and the reduction of time installation.
- 30-loop design for current input measurement: 6 loops for main circuits; 24 loops for branch circuits
- Flexible phase wire connection: a set of three current terminals can be set as 1P2W/ 1P3W/ 3P3W/ 3P4W to proceed load measurement depends on the setting of the phase wire for main circuit.
- Example: when one of the branch loops was set as 1P2W, then each current terminal could connect with other phase voltage to achieve load balancing( main circuit is set as 3P4W).
- There're 15 current terminals on upper and lower sides which are completely isolated. They can be used for dual power system measurement.
- Each loop is equipped with the function of THD and 31st HD measurement that can be applied on the monitoring of power quality in the industries of precise manufacturing/ semiconductor devices.
- Each loop is able to proceed TOU for electricity cost sharing of rental market. Ethernet Modbus TCP is optional for the second communication. And the dual-port design and daisy-chaining capability remove need for additional switches.
- Offer 2MB Flash ROM for data log.
- Dot-matrix LCD display with conversational user interface, easy for on-site operation; offer setting software for batch setting.
- Offer 2 sets of DI and 4 sets of relay outputs for multiple function of I/O control functions for on-site monitoring/ alarm.
- Offer 1 set of RS485 Modbus RTU and optional requirement for another set of RS485, or Ethernet (Modbus/TCP).
- Optional colorful touch screen over 7" size (HMI) for job site needs.
- Designed to CE standard and Cat II standard.

## Applications

- Rental buildings / apartment
- Dormitories/ exhibition booths
- Street shops/ workshops
- Aims at distributed electricity management

**Ordering Information**

10 Loops

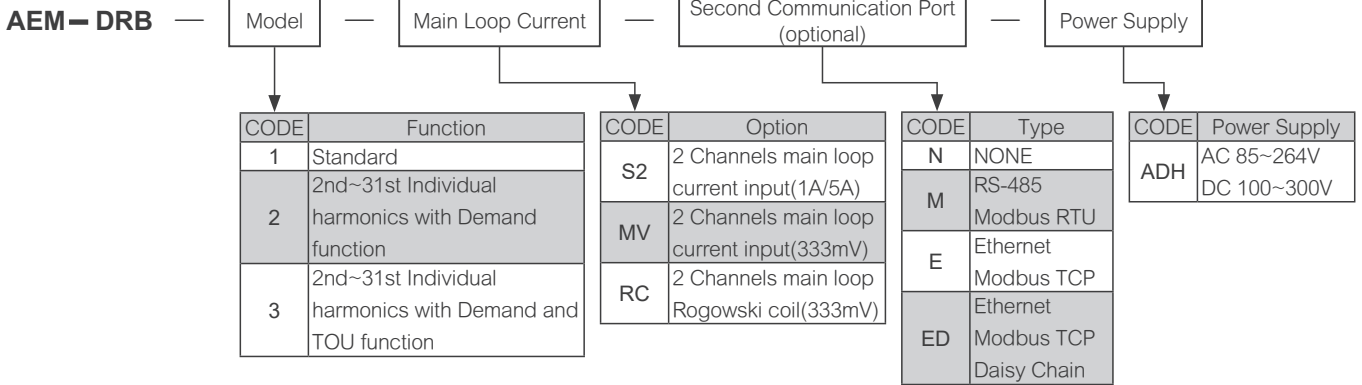

5 Loops

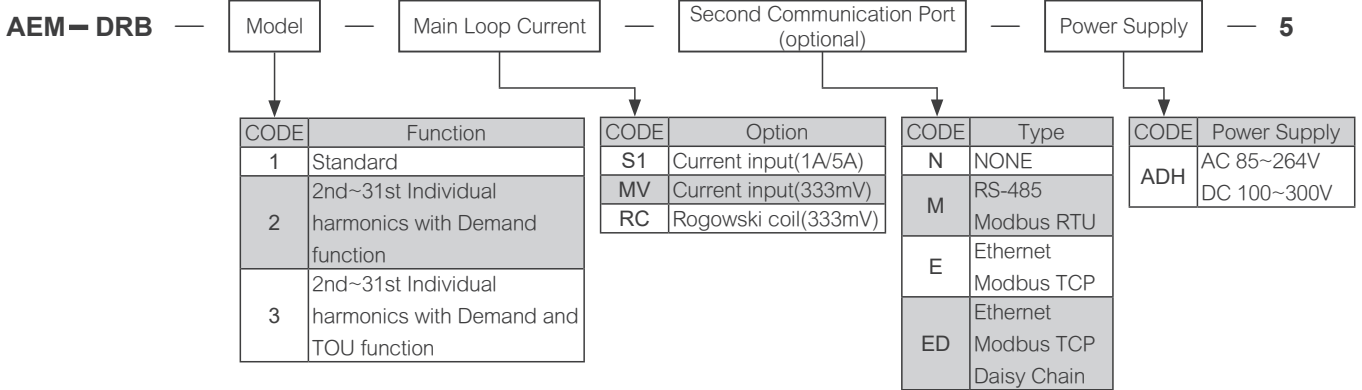

**Meter Selection Guide**

		DRB1	DRB2	DRB3
Voltage	Total and per phase	●	●	●
Current	Total and per phase of main loop and branch loop	●	●	●
Active Power	Total and per phase of main loop and branch loop	●	●	●
Reactive Power	Total and per phase of main loop and branch loop	●	●	●
Apparent Power	Total and per phase of main loop and branch loop	●	●	●
Power Factor	Total and per phase of main loop and branch loop	●	●	●
Frequency	Frequency	●	●	●
Active Energy	Import, Export, Total and Net energy and per phase of main loop and branch loop	●	●	●
Reactive Energy	Import, Export, Total and Net energy and per phase of main loop and branch loop	●	●	●
Apparent Energy	Total and per phase of main loop and branch loop	●	●	●
THD/Voltage	Total and per phase (True RMS and Fundamental)	●	●	●
THD/Current	Total and per phase of main loop and branch loop (True RMS and Fundamental)	●	●	●
Individual Harmonic	2nd~31st Individual harmonics of main loop and branch loop		●	●
Demand	Per phase and 3-phase of current and power		●	●
Unbalance	Current and voltage	●	●	●
Max/Min Values	Per phase and 3-phase of parameters values	●	●	●
Data Logging	With a 2MB memory capacity and a setting of "10 data points recorded per minute, each data point being 4 bytes", data can be recorded continuously for 28 days, storing a total of 40,300 records. The following parameters can be set to logging: frequency, phase voltage, line voltage, current of each loop, active/reactive/apparent power, active/reactive/apparent energy	●	●	●
1st Port of Comm.	RS-485 Modbus RTU	●	●	●
2nd Port of Comm.	RS-485 Modbus RTU or Ethernet Modbus TCP	◎	◎	◎
Digital Input	DI1, DI2	●	●	●
Pulse Output	PO	●	●	●
Relay Output	RO1, RO2, RO3, RO4	●	●	●
Time of Use	4 time zones, 8 periods, 4 tariff			●
Date and Time	Year, Month, Day, Hour, Minute, Second	●	●	●
Timer	Operating hours, Running hours			

◎ Optional  
Rev 1.11

## Accuracy & Resolutions

Parameter	Accuracy	Resolution	Measurement Range
Voltage	0.2%	0.1V	20~400V L-N / 35~690V L-L
Current	0.2%	0.001A	1%~120% CT rating current
Neutral Current	1.0%	0.001A	1%~120% CT rating current
Active Power	0.5%	1W	-999,999,999~999,999,999W
Reactive Power	0.5%	1Var	-999,999,999~999,999,999Var
Apparent Power	0.5%	1VA	0~999,999,999VA
Power Factor	0.5%	0.001	-0.020~+1.000~0.020
Frequency	0.05%	0.01Hz	45.00~65.00Hz
Active Energy	Class 0.5S	0.1kWh	-99,999,999.9~99,999,999.9kWh
Reactive Energy	Class 0.5S	0.1kVarh	-99,999,999.9~99,999,999.9kVarh
Apparent Energy	0.5%	0.1kVAh	0~99,999,999.9kVAh
THD	1.0%	0.1%	0~100.0%
Individual Harmonic	1.0%	0.1%	0~100.0%
Unbalance	0.5%	0.1%	0~300.0%
Current demand	0.2%	0.001A	0.000~9,999A
Active Power demand	0.5%	1W	-999,999,999~999,999,999W
Reactive Power demand	0.5%	1Var	-999,999,999~999,999,999Var
Apparent Power demand	0.5%	1VA	0~999,999,999VA

\*Accuracy non-include clamp CT ratio error

## Technical Specification

### Electrical Characteristics

Measurement: True RMS measurement  
 Sample rate: 256 point/cycle  
 Input channel: 2 main loop input  
 8 channels three-phase or  
 24 channels single-phase  
 Display refresh rate: 0.5s  
 Power system: 1P2W, 1P3W, 3P3W, 3P4W  
 Input range: Voltage: 20~400VLN ; 35~690VLL  
 PT primary ratio:100V~9999KV  
 PT secondary ratio:50~600V  
 Current:  
 Main loop input:5A / 1A / 333mV  
 Branch loop input:333mV  
 CT primary ratio:5~9999A  
 Overload capacity: Current: 2 x rated continuous; 20x rated / 1s

### Power Quality

THD: Total harmonic distortion for voltage and current (True RMS and Fundamental)  
 Individual harmonic: 2nd~31st individual harmonics of voltage and current and odd, even harmonic content  
 Unbalance: 3-phase voltage and current

### Display Characteristics

Display panel: 128\*64 dots matrix LCD with white backlight  
 LED indicator: Power / COM1 / COM2 / Data logging / TOU  
 Power parameters: Display 5 power parameters in one page  
 Date & Time: Perpetual calendar for date and time  
 Loading type: Display IND or CAP loading type  
 Permanent display: Four kinds of front page display settings for quick usual check

### Demand

Calculation method: Block / Sliding  
 Period: 1~60 min  
 Rev 1.11

Demand record: Max value and time stamp

### Relay Output(RO)

Relay capacity: 4 channels SPST(1a); 5A/250Vac; 5A/30Vdc  
 Function mode: Alarm / DO  
 Action mode: Hi / Lo / Hi.Hold / Lo.Hold  
 Alarm set points: Each relay can set 12 groups of alarm conditions, and each condition can correspond to 34 loops and 12 parameters for alarm setting

### Digital Input(DI)

Input capacity: 2 channels digital input; mechanical contact or open collector input are available  
 Function mode: Can be set to DI / Demand reset / Max. Demand reset / Energy reset / Max. and Min. reset / Relay reset  
 Debouncing time: 0~99 (x8mS) programable

### Pulse Output(PO)

Output capacity: Open collector(O.C.), 30Vdc,30mA(max)  
 Corresponding item: Active or Reactive energy of any loop  
 Output frequency: 40Hz (max)  
 Test pulse output: 3200 Pulse/kWh; duty cycle 50%  
 Can correspond to the active or reactive energy of any loop

### TOU (Time of Use)

4 time zones: 1~4 zones per year  
 8 periods: Each time zone can set 1~8 periods  
 The sharp, peak, valley and normal tariff can be specified for each period  
 Parameters in TOU: Import active energy, import reactive energy, total apparent energy cumulative value and current and power maximum demand for the current month and last month of each tariff and each loop  
 Holiday setting: The date and timetable of holiday for five years can be set individually or set on the same holiday for five years

### Data Log

Log setting: The specified parameters can be recorded according to the set interval time, the interval time can be set from 1 to 32767, and the interval time unit can be set as day, hour, minute, second  
 With a 2MB memory capacity and a setting of "10 data points recorded per minute, each data point being 4 bytes", data can be recorded continuously for 28 days, storing a total of 40,300 records.

Memory storage: 2MB Flash ROM, no battery life issue

### RS-485 Communication (2nd RS-485 port is optional)

Protocol: Modbus RTU mode  
 Baud rate: 1200/2400/4800/9600/19200/38400/57600/115200 bps  
 Response time: <50mS (the interval between a received command completed and data-transfer starting)  
 Data bits: 8 bits  
 Parity: None / Even / Odd  
 Stop bit: 1 or 2  
 Address: 1~247

Distance: 1200M max

### Ethernet (Optional)

Interface: Single or dual port, 10/100M BASE-TX  
RJ45 connector

Dual-port structure: Daisy-chaining capability

Protocol: Modbus TCP

TCP socket: 4 sockets

### Environmental Conditions

Operating temp.: 0~60°C

Humidity rating: 5~95%RH, Non-condensing

Temp. coefficient: ≤ 100 PPM/°C

Storage temp.: -10~70°C

Degree of protection: IP20

Operating altitude(maximum): 2000m above sea-level

### Power Supply

Range: AC 85~264V, 50/60Hz  
DC 100~300V

Power consumption: AC:15VA, DC:5W

### Mechanical Structure

Dimensions: 199mm(L)x118mm(W)x77mm(H)

Material: ABS, Black (with fire-retardant)

Mounting: 35mm DIN Rail (EN50022)

Wire terminal: Voltage / Main loop current / Power / DI / RO / PO:  
AWG:28~12 / 0.08~3.31mm<sup>2</sup>  
Screw Torque Value: M2.5 / 5.202kgf.cm (Max)

Branch loop current / RS-485:  
AWG:28~14 / 0.08~2.08mm<sup>2</sup>  
Screw Torque Value: M2 / 2.04kgf.cm (Max)

Weight: 5A main loop: 735g; 333mV main loop: 685g

### Safety

Isolation: AC 2.5KV, 50/60Hz, for 1 min, Between Power / Input / Output / Case

Surge: AC±4KV, 1.2/50us; Voltage input/ Power

Insulation resistance: ≥ 100MΩ @ 500Vdc

EMC: EN61326-1:2013  
EN55011:2016  
EN61000-3-2:2014  
EN61000-3-3:2013  
IEC61000-4-2:2008  
IEC61000-4-3:2006+A1:2007+A2:2010  
IEC61000-4-4:2012  
IEC61000-4-5:2014+A1:2017  
IEC61000-4-6:2013/COR1:2015  
IEC61000-4-8:2009  
IEC61000-4-11:2004/A1:2017

Safety(LVD): EN61010-1:2010+A1:2019

FCC: FCC 47 CFR Part15 Subpart B Class A

### Accuracy Standard

Measurement accuracy: IEC 61557-12 : 2018/AMD1 : 2021

Active energy: Class 0.5S(IEC 62053-22:2020)

Reactive energy: Class 0.5S(IEC 62053-24:2020)

### Carbon Footprint Verification

Standard: ISO 14067:2018/CNS:14067:2021

Carbon emissions: 64.7319(KgCO<sub>2</sub>e)/per set

## Dimensions

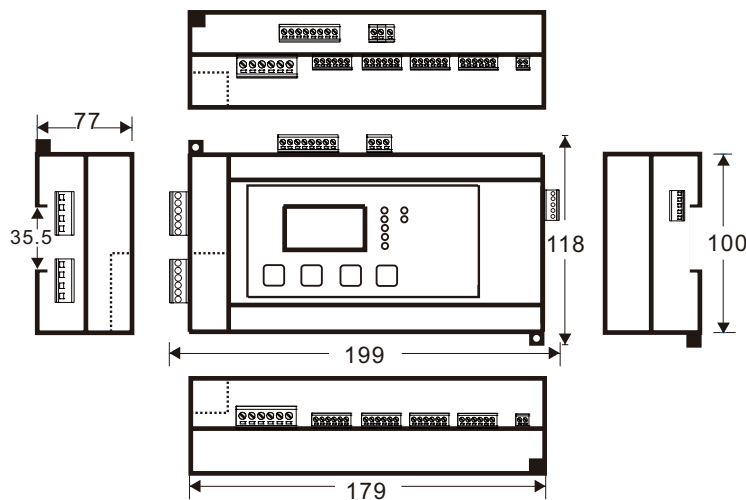

Unit: mm

## Terminal Block

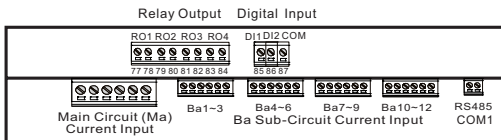

10 Loops

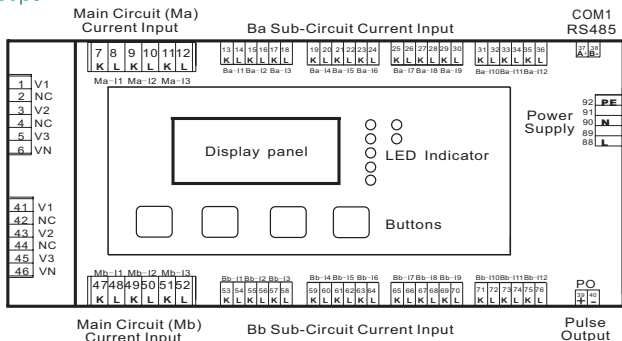

5 Loops

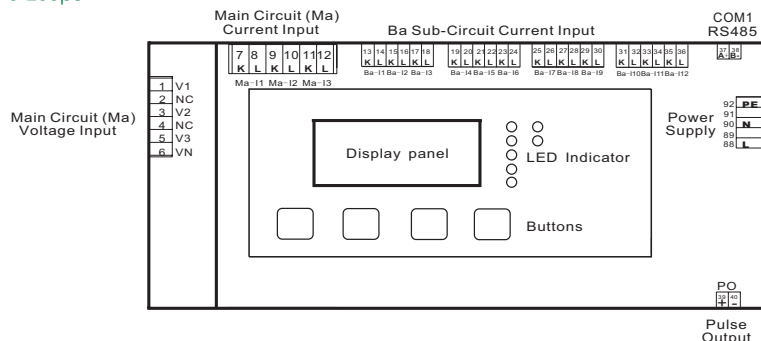

## Meter Wiring Connection (10 Loops) - Main Loop (Ma, Mb)

The two main loop of Ma and Mb are isolated design and can be connected to the different power system. Please refer to the following wiring example for description.

Example 1:

Single Main Loop: 3P4W

CT input can be connected with Ma or Mb.

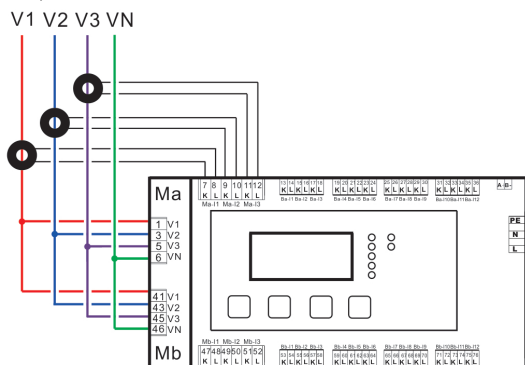

Example 2:

Twin Main Loop: 3P4W+3P3W

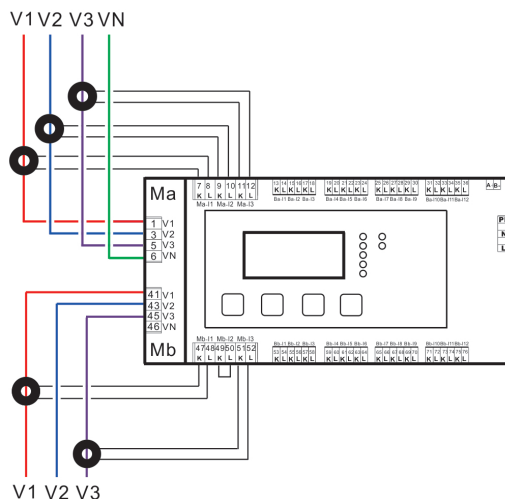

Example 3:

Twin Main Loop: 3P4W+1P3W

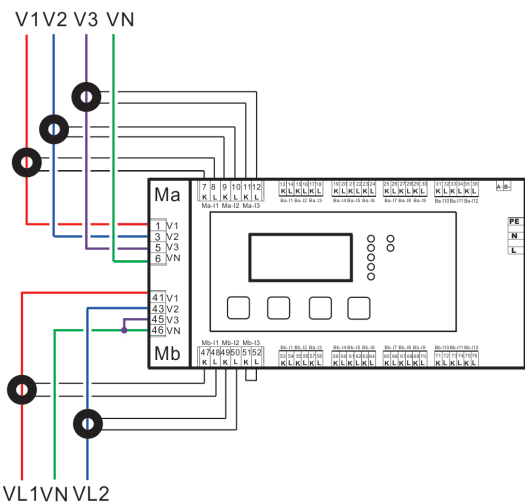

Example 4:

Twin Main Loop: 3P4W+1P2W

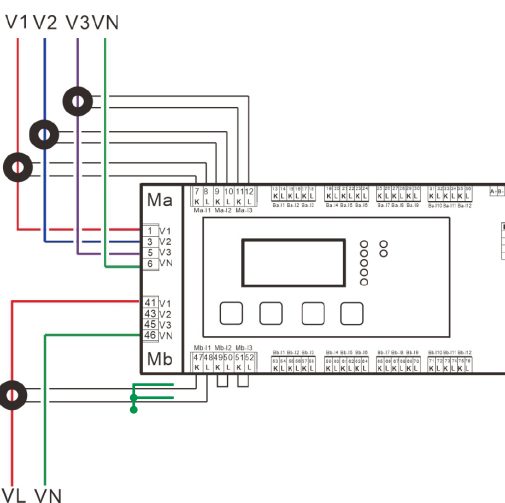

**Meter Wiring Connection (10 Loops) - Branch Loop** (Attention: the secondary side of clamp CT is 333mVac)

The voltage of each loop corresponds to the default, such as Ba 1~3 corresponds to V1~V3, and so on. The corresponding voltage phase can be set and adjusted according to the phase line measured by the actual CT.

Each loop can independently set the wiring system, but it will be limited according to the power system, see the table below:

Power system	available wiring system of the branch loop			
	1P2W	1P3W	3P3W	3P4W
1P2W	○	X	X	X
1P3W	○	○	X	X
3P3W	○	X	○	X
3P4W	○	X	○	○

Example 1:

Power system: Ma=Mb=3P4W

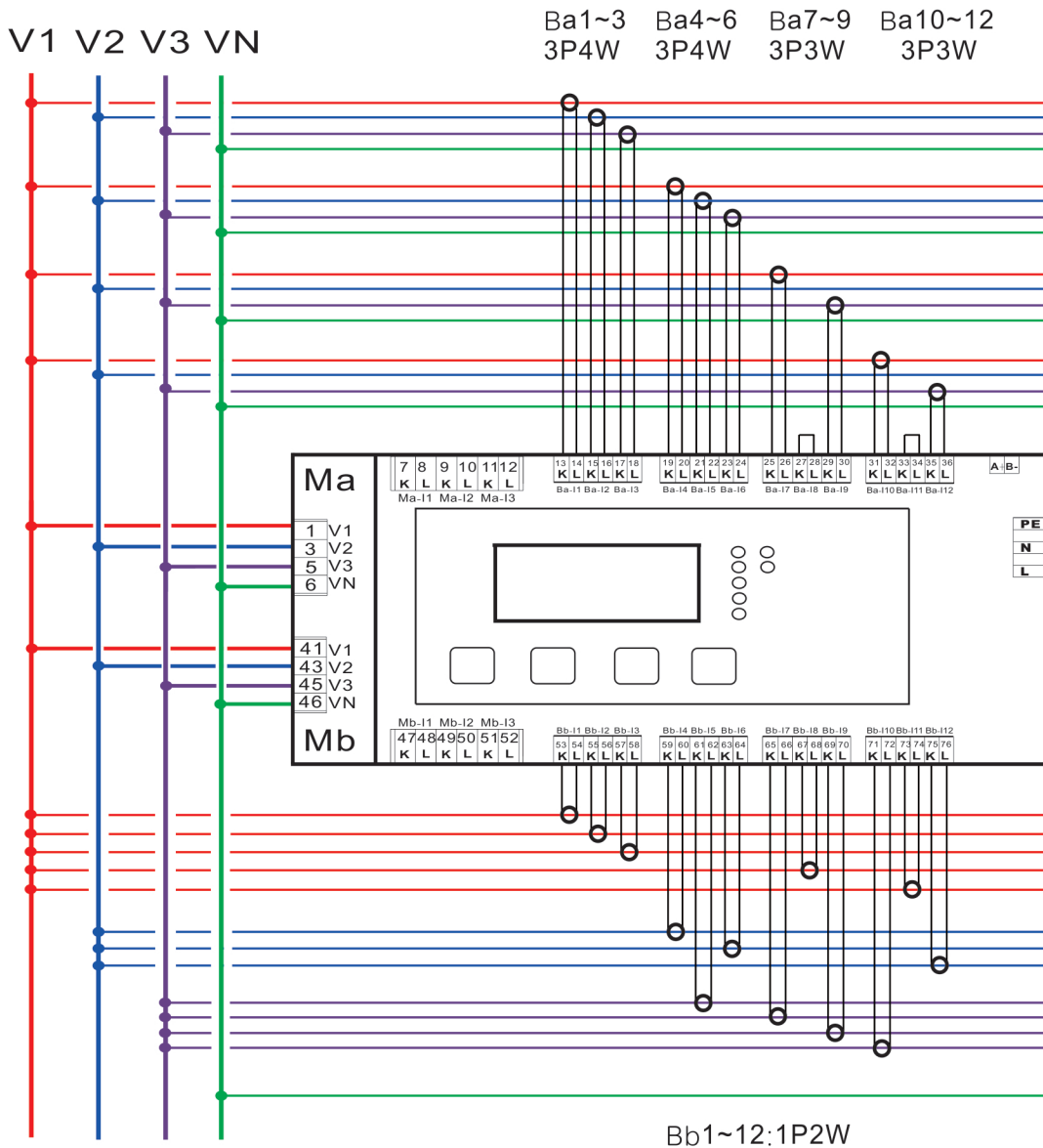

Example 2:

Power system: Ma=3P4W

Mb=3P3W

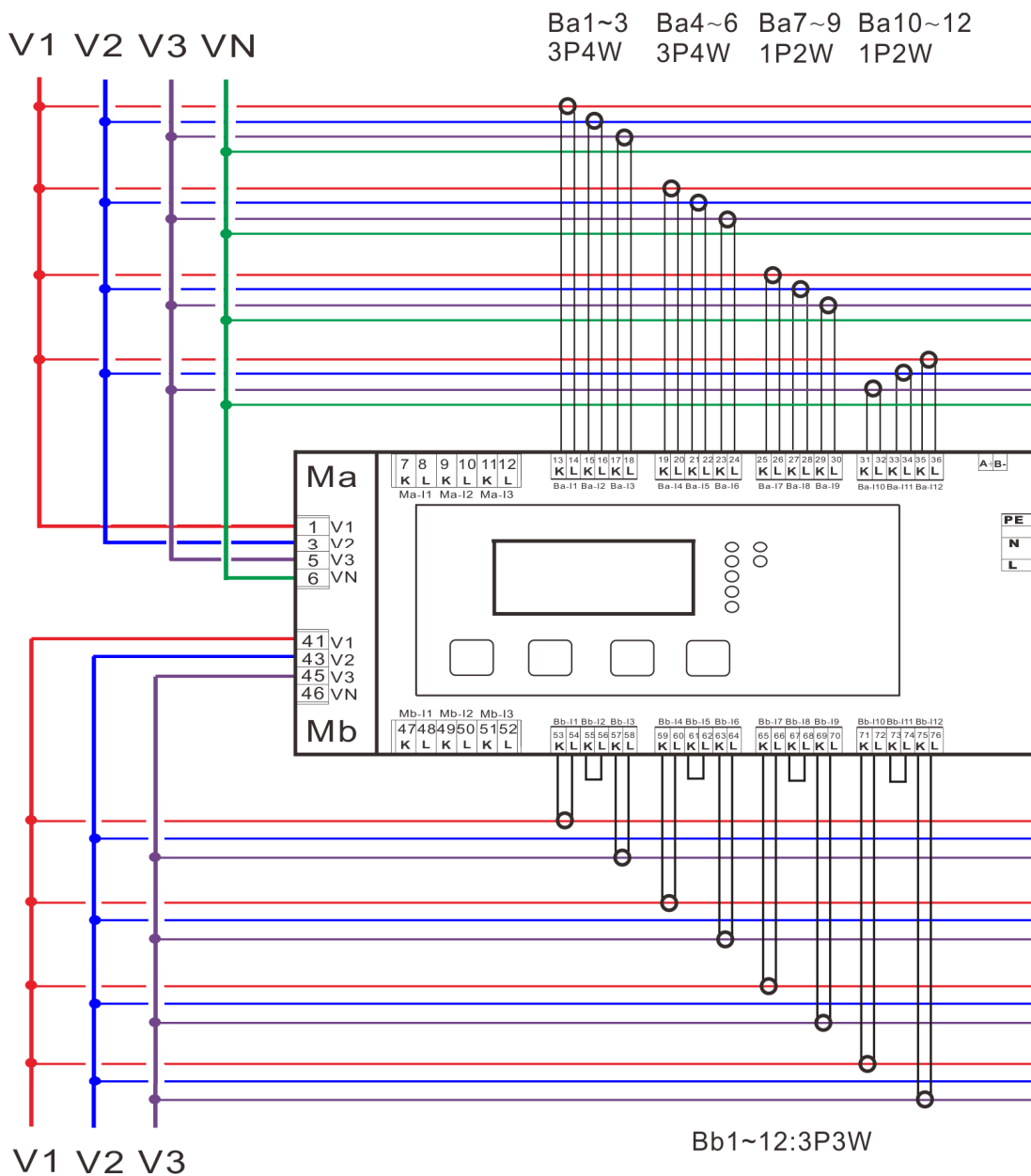

Example 3:

Power system: Ma=3P4W

Mb=1P3W

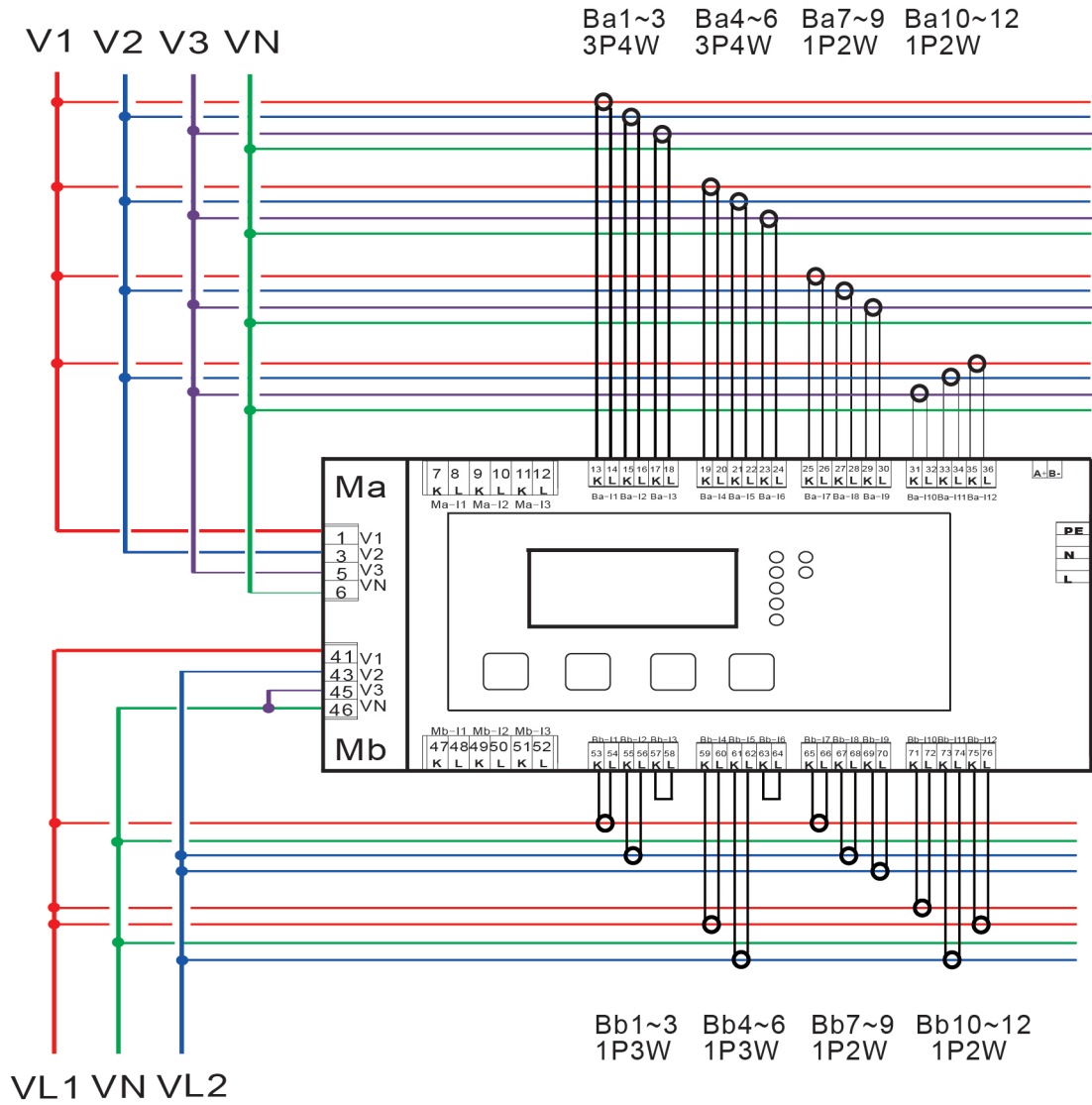

Example 4:

Power system: Ma=3P4W

Mb=1P2W

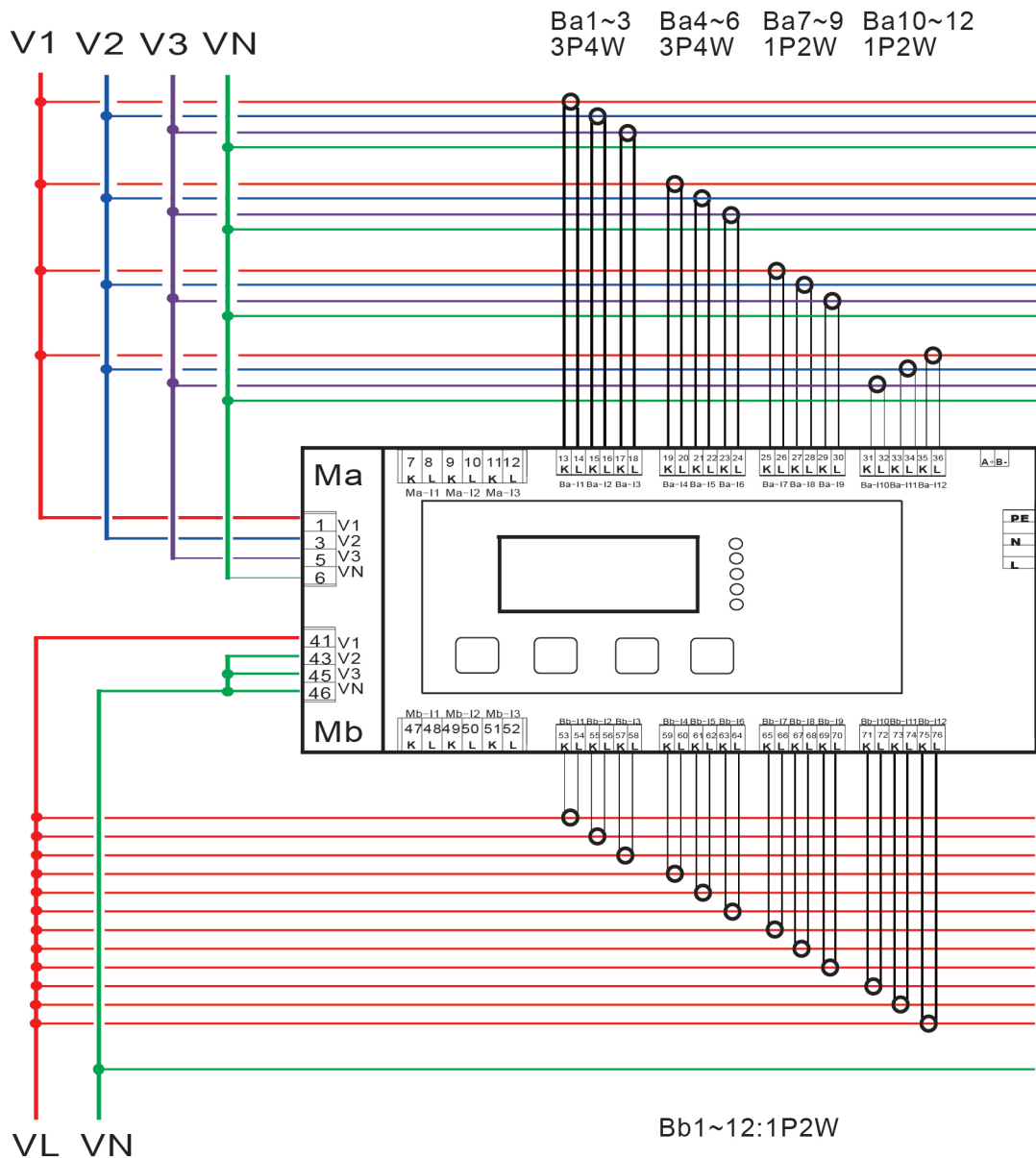

**Meter Wiring Connection (5 Loops) - Main Loop (Ma \ Mb)**

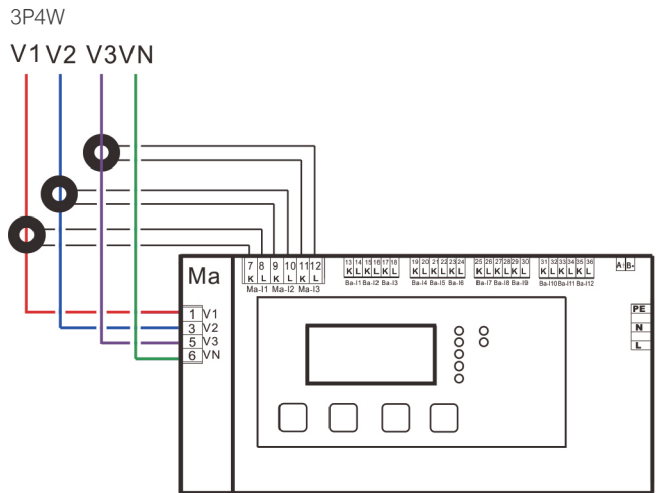
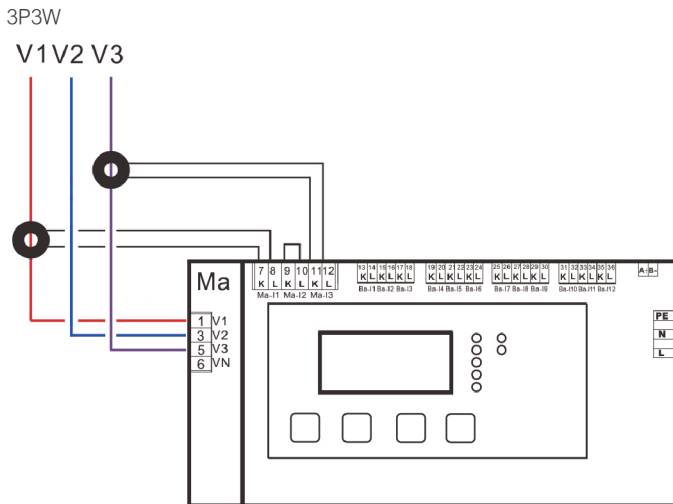
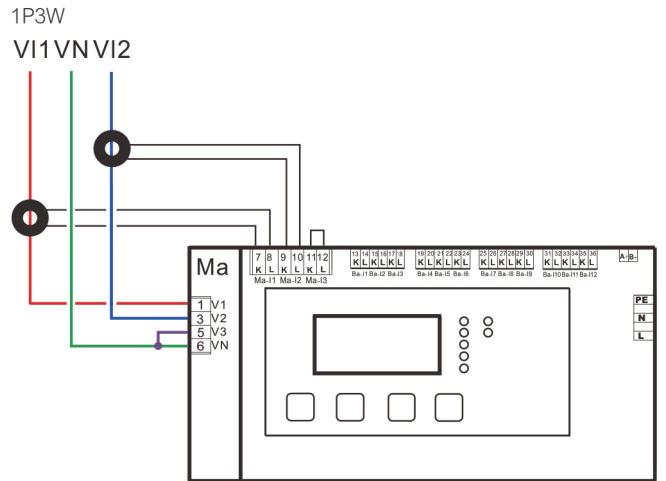
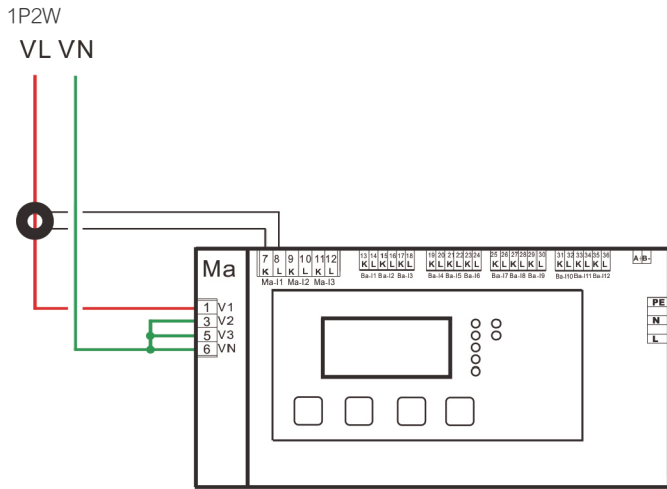

## Meter Wiring Connection (5 Loops) - Branch Loop (Attention: the secondary side of clamp CT is 333mVac)

The voltage of each loop corresponds to the default, such as Ba 1~3 corresponds to V1~V3 , and so on. The corresponding voltage phase can be set and adjusted according to the phase line measured by the actual CT.

Each loop can independently set the wiring system, but it will be limited according to the power system, see the table below:

Power system	available wiring system of the branch loop			
	1P2W	1P3W	3P3W	3P4W
1P2W	○	X	X	X
1P3W	○	○	X	X
3P3W	○	X	○	X
3P4W	○	X	○	○

Example 1:  
Power system: 3P4W

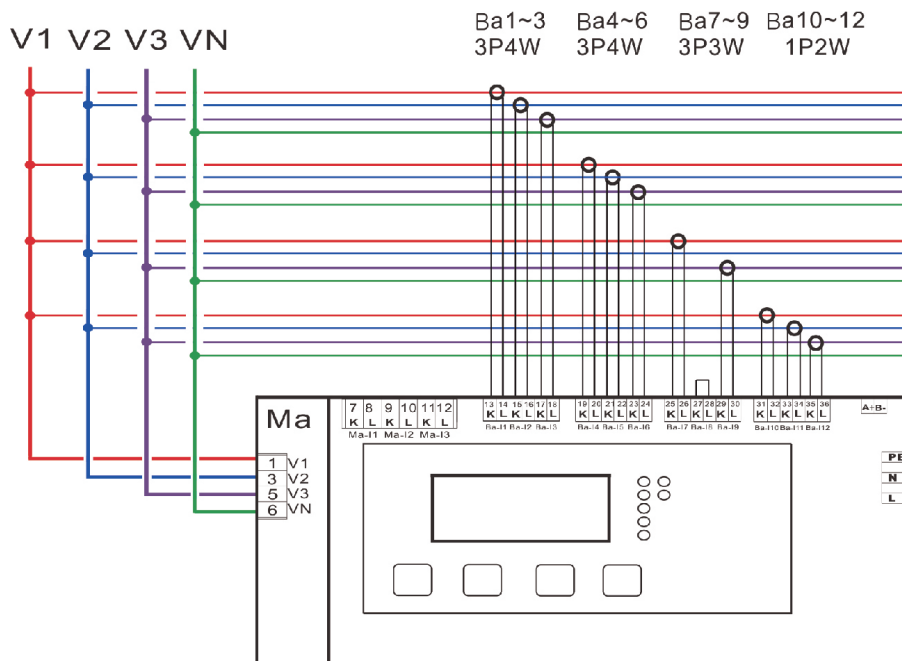

Example 2:  
Power system: 3P3W

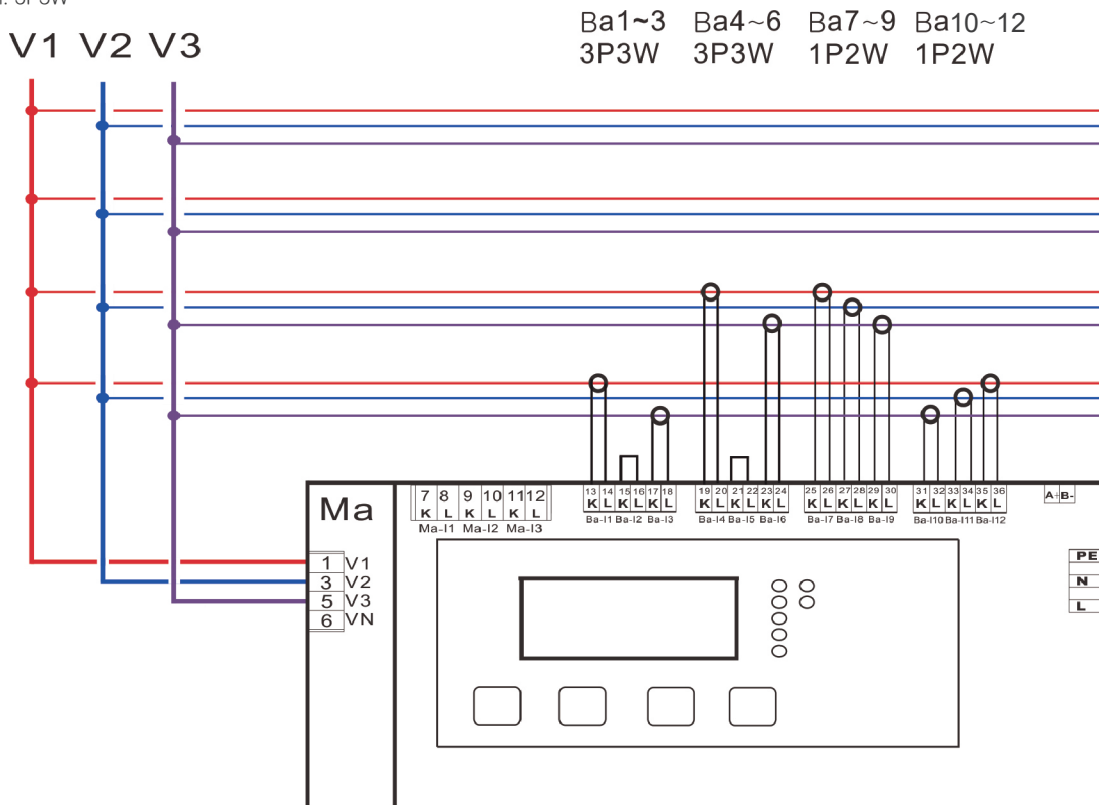

Example 3:  
Power system: 1P3W

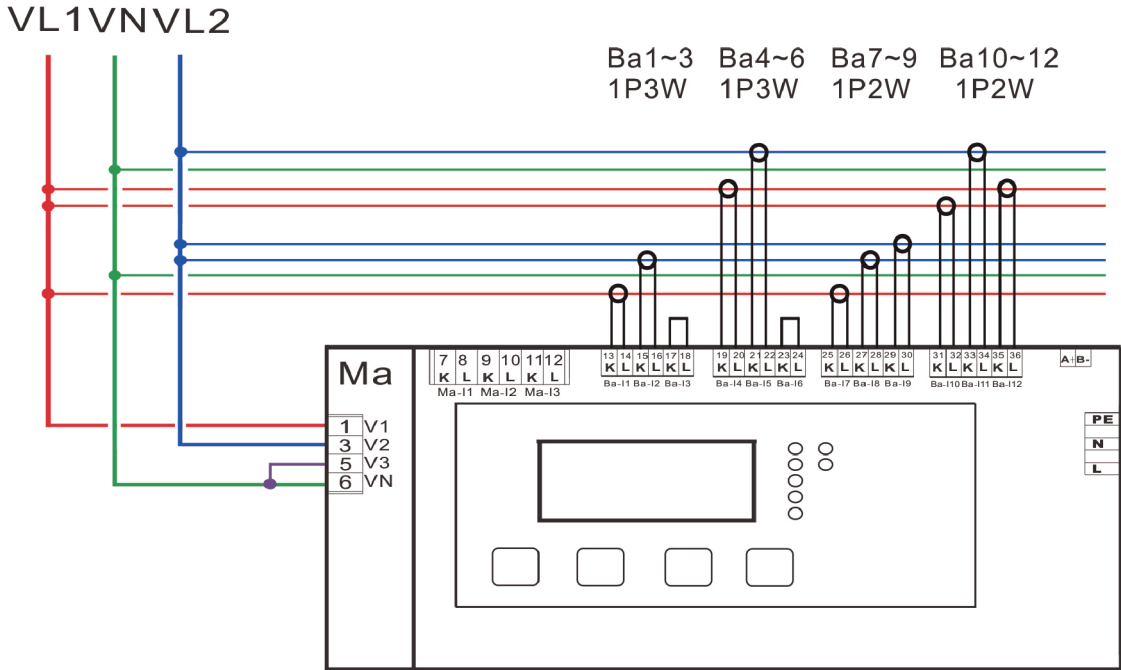

Example 4:  
Power system: 1P2W

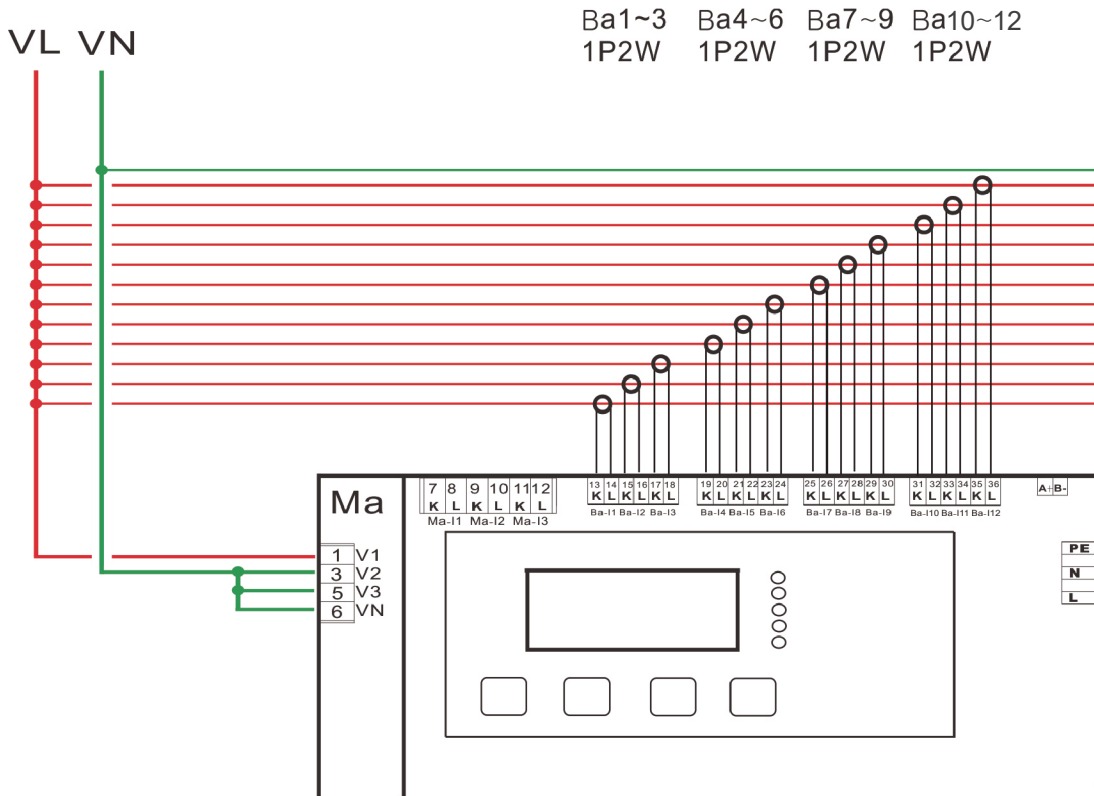

## Output & Input Connection

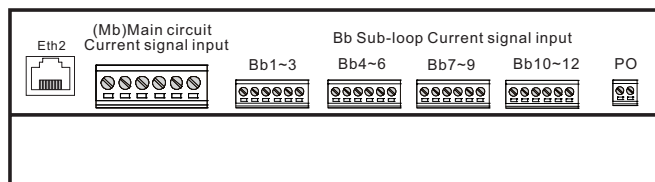
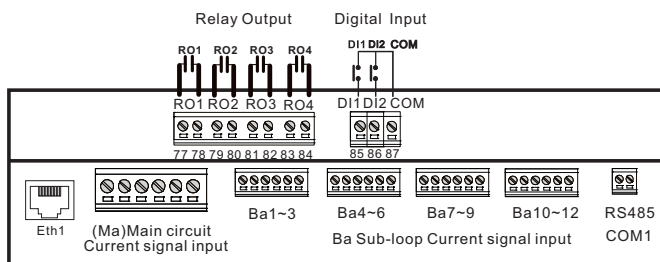
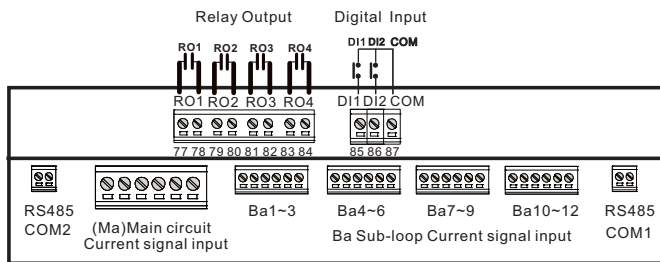

## Communication and Power Supply

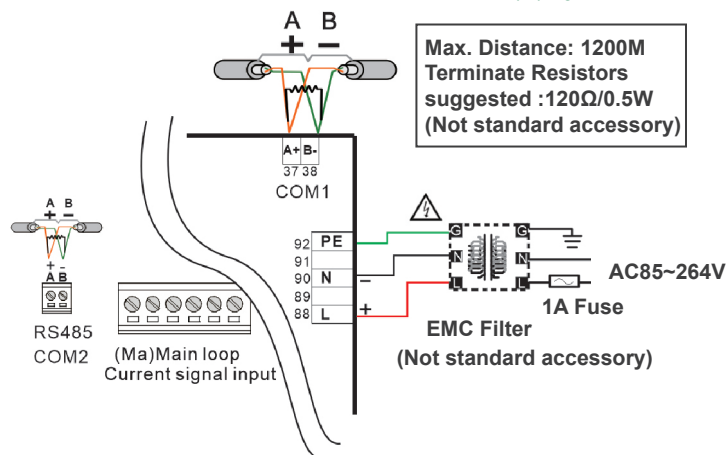

## Pulse Output

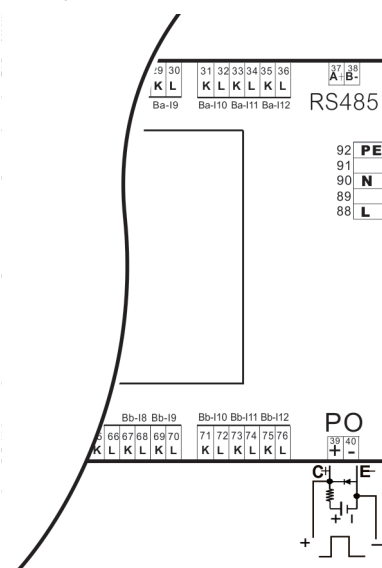

## Split Core CT Ordering Information

(The output line of mV on the secondary side of the CT needs to be wired independently, and cannot be connected together or grounded for protection purposes.)

**US – CTV**



CODE	Diameter(mm)	CODE	Rated Current
10	Φ10	005	5A
16	Φ16	060	60A
		100	100A
		150	150A
24	Φ24	200	200A
35	Φ35	300	300A
		400	400A
		600	600A
50	Φ50	800	800A

CODE	Cable Spec.
LSFH	Low smoke zero halogen
This code is not filled when there is no optional function	

Type	Current of primary (A)	Voltage of secondary (mV)	Accuracy %F.S.	Weight
US-CTV-10-005	5A	333	1.0	60g
US-CTV-16-060	60A	333	0.5	100g
US-CTV-16-100	100A	333	0.5	100g
US-CTV-16-150	150A	333	0.5	100g
US-CTV-24-200	200A	333	0.5	205g
US-CTV-35-300	300A	333	0.5	375g
US-CTV-35-400	400A	333	0.5	375g
US-CTV-35-600	600A	333	0.5	375g
US-CTV-50-800	800A	333	0.5	655g



## Human-Machine Interface (Optional)

**Model: AD-HMI2070-31ST**

- 7" colorful touch screen, resolution: 800x480
- 4-wire resistive touch screen
- DC24V power supply
- Front panel with IP65 protection degree
- Allowing up to six AEM-DRB devices connected to one HMI by RS-485 or Ethernet communication
- Providing parameters of main and branch loops, such as, voltage, current, frequency, power factor, power, energy, demand
- Dimensions: 201.0 x 147.0 x 38.3mm

※For more details, please see AD-HMI datasheet.

