

# AEM-DRK

## Multi Circuit Power Meter(DIN rail) Operation Manual



# Content

Chapter 1 Product Overview.....	1
1.1 Foreword .....	1
1.2 Outward & Instructions .....	1
1.3 Warning & Criterion .....	2
Chapter 2 Specifications.....	4
2.1 Electrical Spec. ....	4
2.2 Communication Spec. ....	5
2.3 Operation Interface .....	5
2.3.1 Menu Tree.....	6
2.4 Dimensions .....	8
Chapter 3 Installation.....	10
3.1 Installation Method .....	10
3.1.1 Environment.....	10
3.1.2 Remind.....	10
3.2 Basic Test .....	11
3.3 Wiring Instructions .....	12
3.3.1 Wiring Diagram.....	12
3.3.2 Communication Features.....	14
Chapter 4 Operations.....	15
4.1 General Operations .....	15
4.1.1 Reading Data.....	15
4.1.1.1 Summary Page Inquire.....	15
4.1.1.2 Power Parameter Inquire.....	15
4.1.1.3 Energy Inquire.....	16
4.1.1.4 Alarm Inquire.....	16
4.1.2 Data Clear & Reset.....	17
4.1.3 Meter Information.....	17
4.1.4 User Password.....	17
4.1.5 General Setting.....	18
4.1.5.1 Wire System.....	18
4.1.5.2 PT Setting.....	18
4.1.5.3 CT Setting.....	19

4.1.5.4	Each Loop Voltage Phase Assign.....	19
4.1.5.5	Modify Password.....	19
4.1.5.6	Default Page.....	20
4.1.6	Communcion.....	20
4.1.6.1	Address.....	20
4.1.6.2	Baudrate.....	21
4.1.6.3	Parity.....	21
4.1.6.4	Ethernet Setting.....	21
4.1.6.5	Module Control.....	22
4.1.7	Pulse Output.....	22
4.1.7.1	Test Pulse.....	22
4.1.7.2	Target Loop.....	22
4.1.7.3	Energy Type.....	23
4.1.7.4	Pre-Divider.....	23
4.1.7.5	Time of Level High.....	23
4.1.8	Energy Unit.....	23
4.1.9	Date/Time.....	24
4.1.9.1	Backlight Time.....	24
4.1.9.2	Date.....	24
4.1.9.3	Time.....	24
4.1.9.4	Operation Hour Reset.....	24
4.1.9.5	Running Hour Reset.....	25
4.1.10	Demand.....	25
4.1.10.1	Mode.....	25
4.1.10.2	Period.....	25
4.1.11	Input/Output.....	25
4.1.11.1	Digital Input.....	25
4.1.11.2	Relay Output.....	26
4.1.12	Initial.....	27
4.2	Measurement algorithm.....	27
4.2.1	Harmonic.....	27
4.2.2	Demand.....	28
4.2.2.1	Sliding Block.....	28
4.2.2.2	Fix Block.....	28
4.3	Block transfer function.....	29

4.4	Data Logging function .....	29
4.4.1	Data logging function setting.....	29
4.4.2	Data log read.....	32
4.5	Time of use (TOU) Function .....	33
4.5.1	Season Setting.....	33
4.5.2	TOU Season Format.....	34
4.5.3	Schedule Setting.....	34
4.5.4	Segment Setting.....	34
4.5.5	Tariff Setting.....	34
4.5.6	Holiday Setting.....	34
4.5.7	Holiday schedule.....	35
4.5.8	Weekend Schedule.....	35
4.5.9	Demand.....	35
4.5.10	TOU Settlement.....	35
Chapter 5	Troubleshooting.....	36
5.1	Common Malfunction Analysis .....	36
5.1.1	Power meter doesn't work after power on.....	36
5.1.2	Voltage or current reading is incorrect.....	36
5.1.3	Power or power factor reading is incorrect, but.. voltage and current are correct.....	36
5.1.4	RS-485 communication is abnormal.....	36

# Chapter 1 Product Overview

## 1.1 Foreword

Thank you for choosing our product. The instruction manual provides installation and maintenance for AEM-DRK.

AEM-DRK is a multi circuit power meter designed for power distribution (CAT II-rated power system) monitoring and control at different types of workplace.

To ensure that it is operated correctly, please read the instruction carefully, and follow the steps below before operating.

- The work environment should be dry, and it should not contain any corrosive gases and flammable gases.
- Please follow the wiring diagram to connect wires.
- The grounding project must be implemented, and follow IEC rules in current region.
- Do not remove the meter or change the wiring when it is energized.
- Do not touch the power supply when it is energized to prevent electric shock.
- Please contact your dealer or our customer service center if you have any operating problem. Also, please contact your dealer or visit our website (<http://www.adtek.com.tw>) to download the latest version when the specification is updated.

## 1.2 Outward & Instructions

The AEM-DRK is equipped with LCD showing 5 kinds of measurement data on one page.

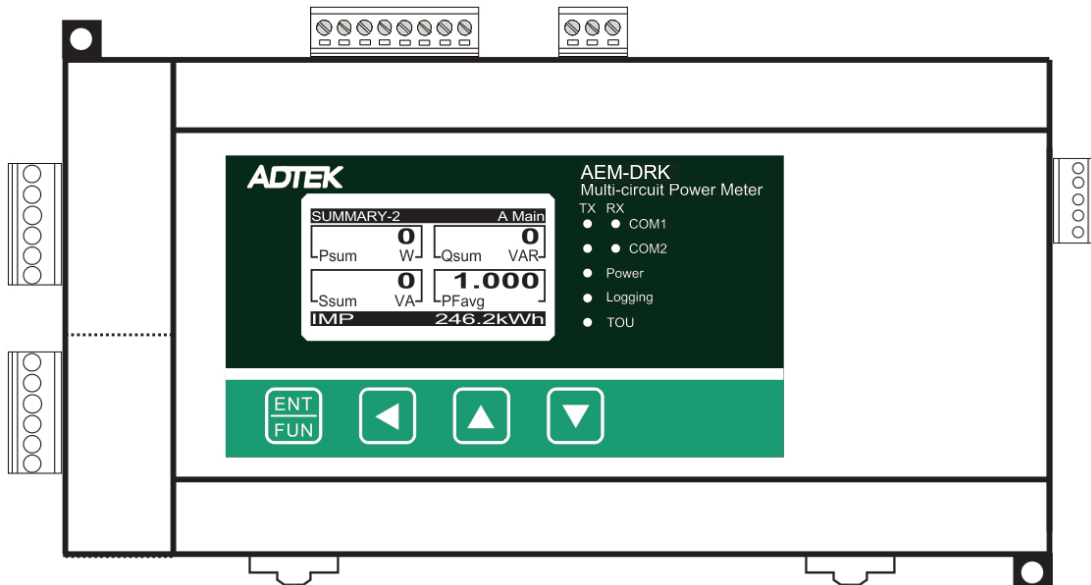

## 1.3 Warning & Criterion

- Attention: installation



- Please wear safety equipment when operating the device and follow the regulations for electrical safety.
- The installation should be operated by licensed engineer who have read this manual carefully.
- To prevent damage and injuries caused by improper operation, please operate the device according to the instruction manual.
- The device should be installed in an insulated and fire-resistant cabinets.

- Attention: operation



- Do not work alone.
- Please turn off the power before installation, checking, and maintenance.
- Please use precision voltage monitoring to ensure that the power has been turned off.
- Please check all mechanical parts, covers, and doors have returned to original position before connecting the power, and make sure no components or tools were left inside the device.

- Attention: wiring



- The secondary side of potential transformer (PT) shouldn't be short-circuited while using.
- Current transformer (CT) should be open-circuited while using.
- To avoid the cable falling off, and cause damage to the equipment, please make sure the cable for the secondary side of current transformer (CT) has been locked out before using.
- Please use current transformer (CT) that meets UL2808 in the United States/Canada; for other countries, please use current transformers (CT) that meets IEC61869-2 or required by AHJ.

- Attention: wiring



- Current transformer (CT) must be used with the device when measuring the current.
- When the measured voltage exceeds the range of rated voltage for the device( line voltage of 35~690VAC L-L; phase voltage: 20~400VAC L-N), then it must go with a potential transformer (PT). Please note that the port of the quick coupling is allowed to connect with one cable only.
- Please re-check the connecting wire and start again if the wire was pulled out by force.

- Maintenance and inspection



- Before cleaning the power meter, please turn off the power, and wipe with dry and soft rag.
- Please do not disassemble the meter while cleaning, or the circuits will be damaged.
- Do not use the cleaning liquid containing acids or bases.

# Chapter 2 Specifications

## 2.1 Electrical Spec.

Accuracy					
Power	Voltage	0.2 %	Energy	Active energy	0.5 %
	Current	0.2 %		Reactive energy	0.5 %
	Active power	0.5 %		Apparent energy	0.5 %
	Reactive power, apparent power	0.5 %	Total harmonics in current	1.0 %	
Power Factor		0.5 %	Total harmonics in voltage		1.0 %
Active power demand		0.5 %	Frequency accuracy		0.05 %
Apparent power demand		0.5 %	Reactive power demand		0.5 %

Input		
Wiring	Single-phase two-wire, 1 CT	Three-phase three-wire, Δ Delta-connection, 2 CT, 2 PT
	Single-phase three-wire, 2 CT	Three-phase three-wire, Δ Delta-connection, 1 CT, 2 PT
	Three-phase three-wire, Δ Delta-connection, 3 CT, No PT	Three-phase four-wire, Y-connection, 3 CT, 3 PT
	Three-phase three-wire, Δ Delta-connection, 2 CT, No PT	Three-phase four-wire, Y-connection, 1 CT, 3 PT
	Three-phase three-wire, Δ Delta-connection, 1 CT, No PT	Three-phase four-wire, Y-connection, 3 CT, No PT
	Three-phase three-wire, Δ Delta-connection, 3 CT, 2 PT	Three-phase four-wire, Y-connection, 1 CT, No PT
Rated voltage	Line voltage: 35 ~ 600 VAC (L-L) Phase voltage: 20 ~ 400 VAC (L-N)	
Rated current	1A / 5A	
Frequency	45~65 Hz	
Measurement categories	CAT II	
Alarm	Selectable alarm parameters	12 sets
Max/Min	53/41	Max/Min, Time stamp
Power supply	Range	85~264 VAC (Power Consumption ≤ 15VA) 100~300 VDC (Power Consumption ≤ 5W)
Frequency	Frequency for power supply	50/60 Hz
Communication Interface	RS-485 Interface	MODBUS-RTU
		Baud Rate 1200 / 2400 / 4800 / 9600 / 19200 / 38400 / 57600 / 115200 bps
Shell	Dimensions (W x H x D)	118 * 77* 199 mm
	IP Protection	IP20

Environment	Operating Temperature	0°C ~ +60°C (32 °F ~ 140 °F )
	Storage Temperature	- 10 °C ~ +70 °C (14 °F ~ 158 °F )
	Relative Humidity	5~ 95 % RH Non-condensing
	Altitude	Below 2000 meters

Display	
Screen	LCD
Backlight	White

Electromagnetic compatibility	
Electrostatic discharge	IEC 61000-4-2:2008
Immunity to radiated fields	IEC 61000-4-3:2006+A1:2007+A2:2010
Immunity to fast transients	IEC 61000-4-4:2012
Immunity to impulse waves	IEC 61000-4-5:2014+A1:2017
Conducted immunity	IEC 61000-4-6:2013/COR1:2015
Immunity to magnetic fields	IEC 61000-4-8:2009
Immunity to voltage dips	IEC 61000-4-11:2004/A1:2017
Radiated emissions	FCC part 15 subpart B Class A
Conducted emissions	FCC part 15 subpart B Class A
Harmonics emissions	EN 61000-3-2:2014
Flicker emissions	EN 61000-3-3:2013

## 2.2 Communication Spec.

Communication	
RS-485	MODBUS RTU
Baud Rate	1200 / 2400 / 4800 / 9600 / 19200 / 38400 / 57600 / 115200 bps

## 2.3 Operation Interface

A.	Title	F.	DOWN key
B.	Display area	G.	COM light
C.	ENTER key	H.	POWER light
D.	LEFT key	I.	LOGGING light
E.	UP key	J.	TOU light

Button	General Mode	Setting
ENTER	Menu	Press to confirm; return to the previous page
LEFT	None	Press for 2 seconds to return to the previous page
UP	Press to switch the summary pages	Select item or increase number
DOWN	Press to switch the summary pages	Select item or decrease number

### 2.3.1 Menu Tree

UI tree: display

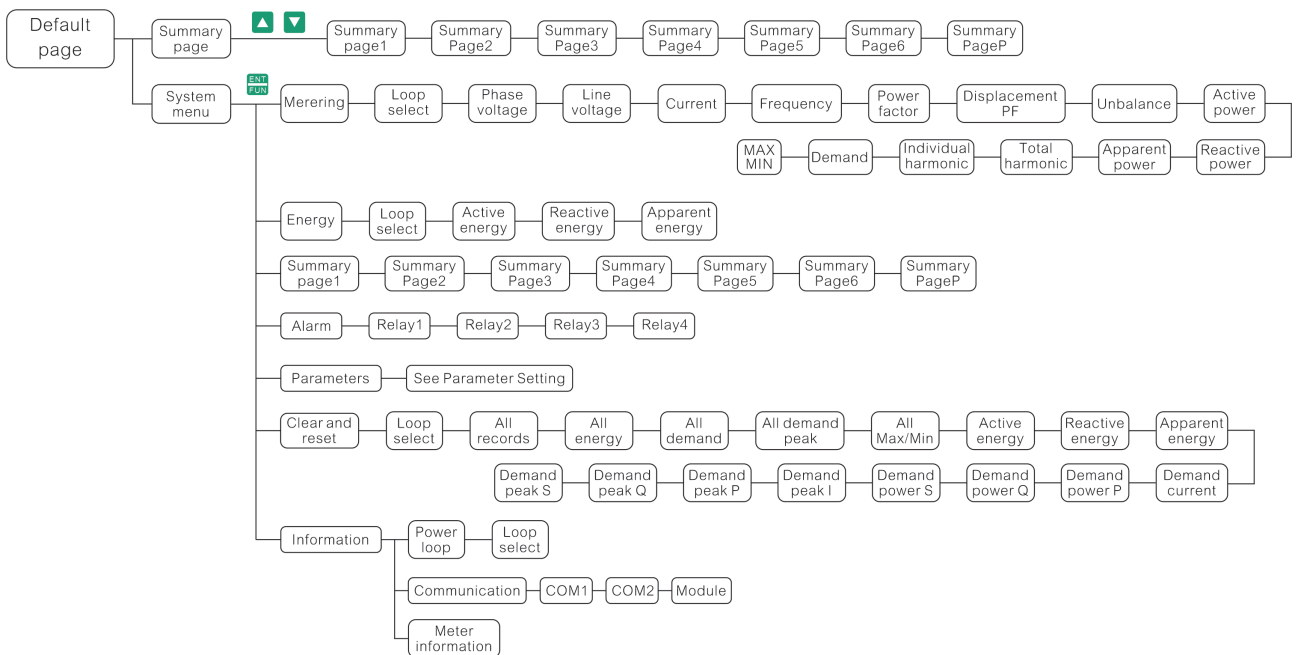

# UI tree: setting

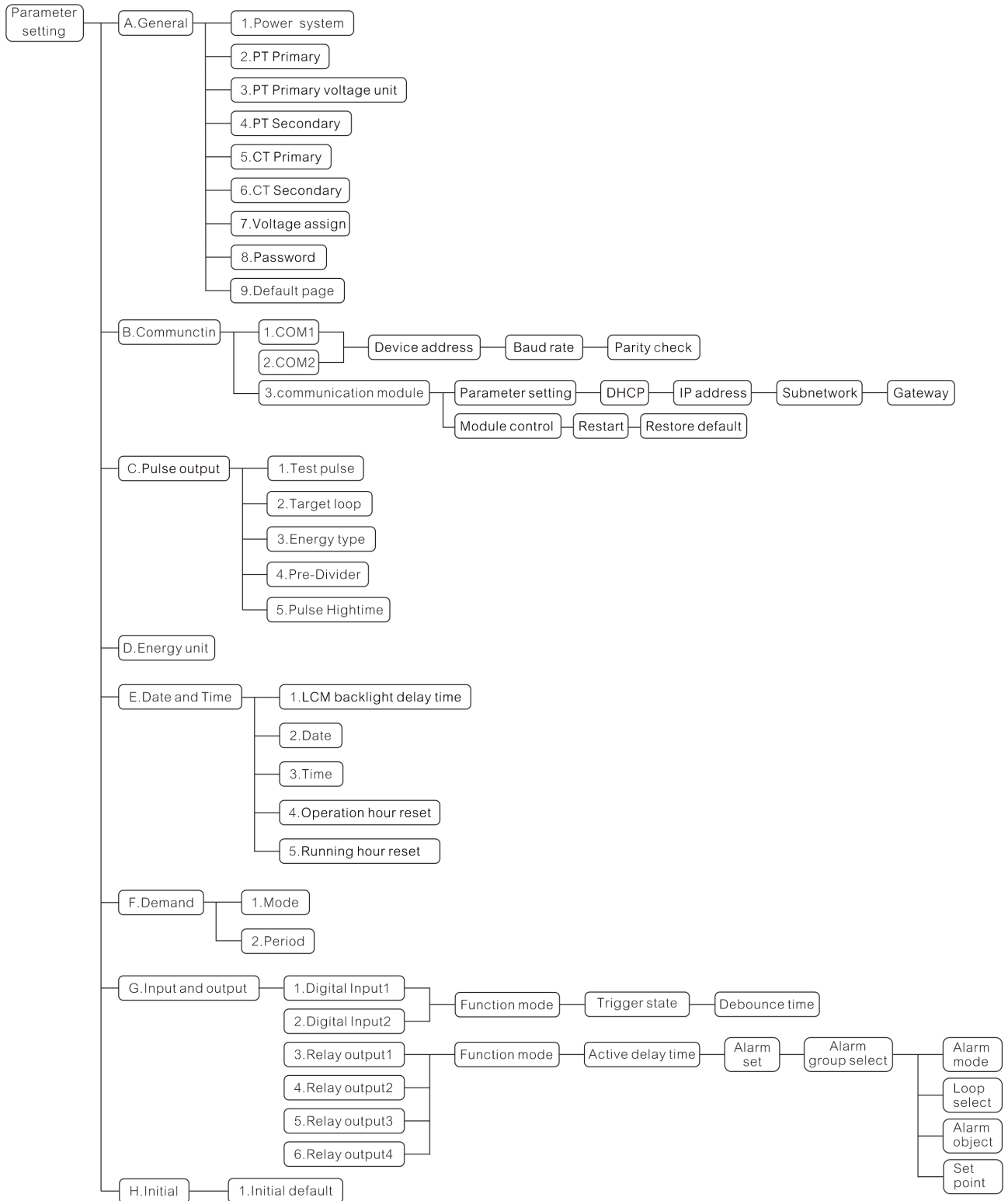

## 2.4 Dimensions

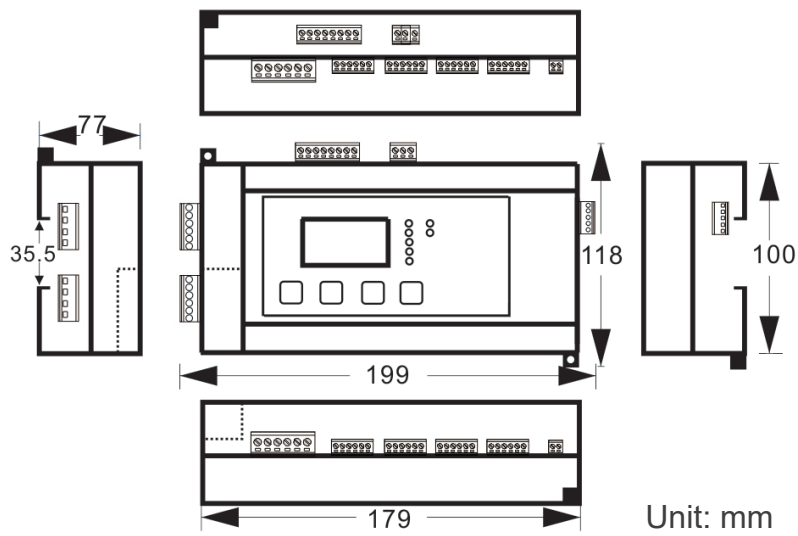

Terminal diagram:

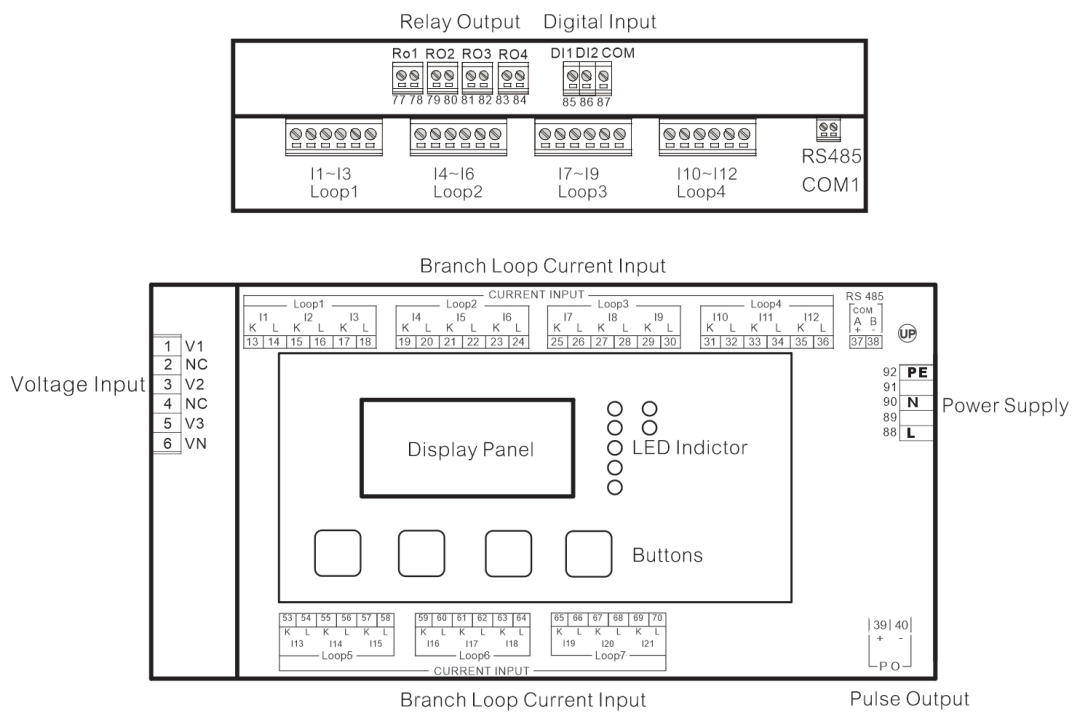

# Input and Output

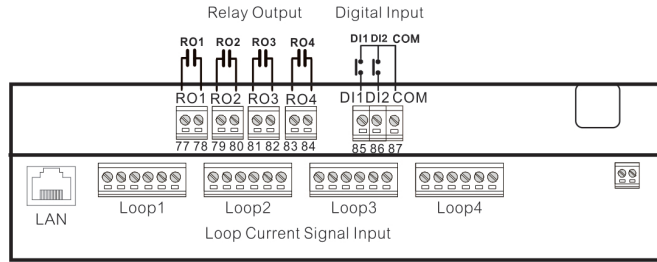
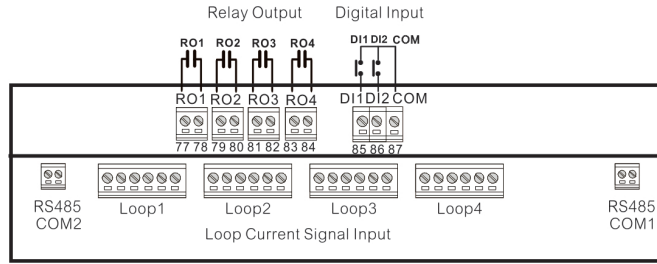

## RS485 Communication Port:

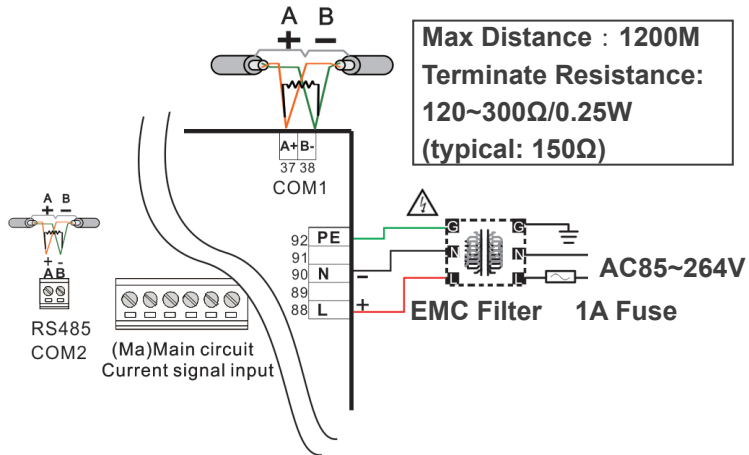

## Pulse Output:

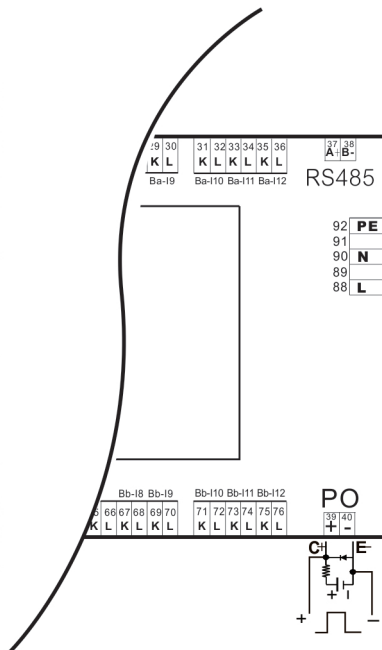

# Chapter 3 Installation

## 3.1 Installation Method

### 3.1.1 Environment

- If the product is temporarily not to be used, please preserve it in the box, and follow the steps below to store the product for the product warranty and future maintenance.
- Must be placed in a dust-free, and dry environment.
- The ambient temperature of the storage must be maintained between  $-10^{\circ}\text{C} \sim +70^{\circ}\text{C}$  ( $14^{\circ}\text{F} \sim 158^{\circ}\text{F}$ ).
- The relative humidity of the storage must be maintained between 5% to 95% without condensation.
- Keep the storage away from the environment containing corrosive gas and liquids.
- The storage should be placed on the shelf or the countertop.
- Recommended installation environment: the places where there is no high heat device, no water droplets, vapors, dust, oily dust, dust, corrosion, flammable gas, liquids, floating dust, and metal particles; vibration-free, and electromagnetic noise-free places.

### 3.1.2 Reminder

- Please follow Installation instruction, or it could cause malfunction.
- It is required to provide adequate space for the power meter and make sure the cooling loop work well( The engineers must keep a distance between the wall and the meter, or it will cause poor heat dissipation).

### 3.2 Basic Test

Test Item	Description
General Testing	<ul style="list-style-type: none"> <li>• Heat sink should be away from oil, water, and metal dust; the power meter should be protected during the process of the drilling.</li> <li>• The power meter should be isolated if it is installed in a place containing hazardous gases and the dust.</li> </ul>
Pre-operation (without power supplied)	<ul style="list-style-type: none"> <li>• The connection part of the wiring terminal should be insulated.</li> <li>• Making sure the communication wiring is correct, otherwise it can't be operated properly.</li> <li>• Check if there is conductive or flammable objects such as screws or metal plates inside the meter.</li> <li>• If the electronic instruments used nearby the meter suffer electromagnetic interference, please adjust the instruments to reduce electromagnetic interference.</li> <li>• Please make sure the supply voltage of the meter is correct.</li> </ul>
Pre-operation (with power supplied)	<ul style="list-style-type: none"> <li>• Please make sure the communication between the devices is operated properly.</li> <li>• Please contact your dealer or our customer service center if you need support for technical issues with our products.</li> </ul>

### 3.3 Wiring Instructions

#### 3.3.1 Wiring diagram

- Notice
  1. Do not change the wiring while operating, or you may get electric shock.
  2. Please install an extra fuse switch under the meter as the power meter is not equipped with a switch.
  3. Voltage measurement : please operate with potential transformer (PT) when the measured voltage is out of the range of the rated voltage that the meter can carry.
  4. Voltage measurement : please operate with current transformer (CT)

Recommended wiring material :

Terminal Block	Wire gauge	Screw torque	Wire temperature resistance
RS-485	AWG 28 ~ 14	2.04 kgf.cm ( 0.2 N· m )	70°C or higher
Aux. power, RO, DI, PO, Measured voltage, Measured current	AWG 28 ~ 12	5.202 kgf.cm ( 0.5 N· m )	70°C or higher

- Wiring method

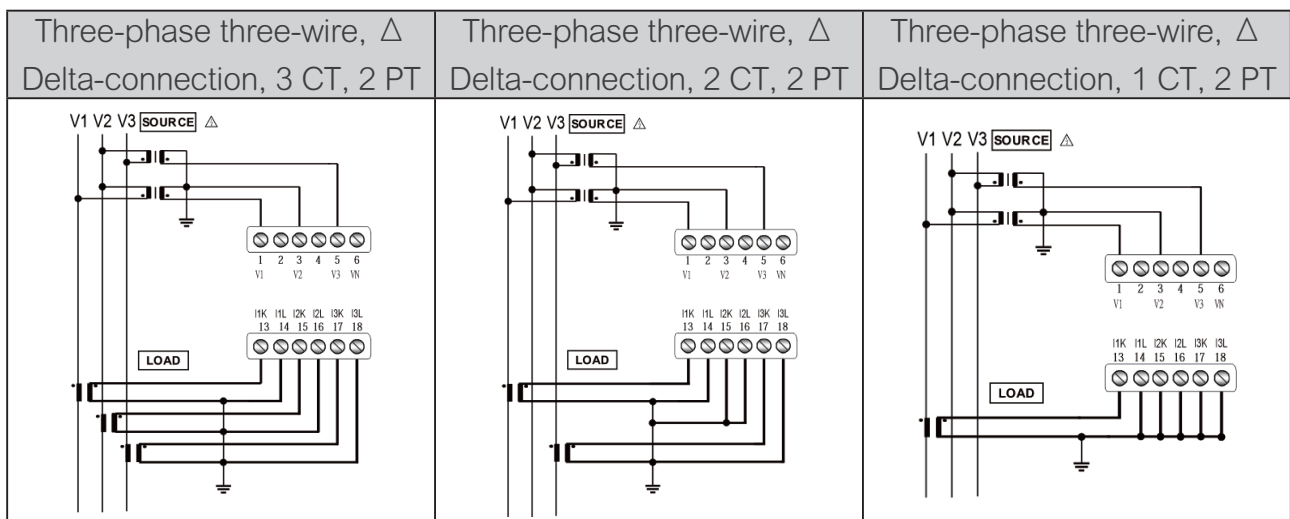
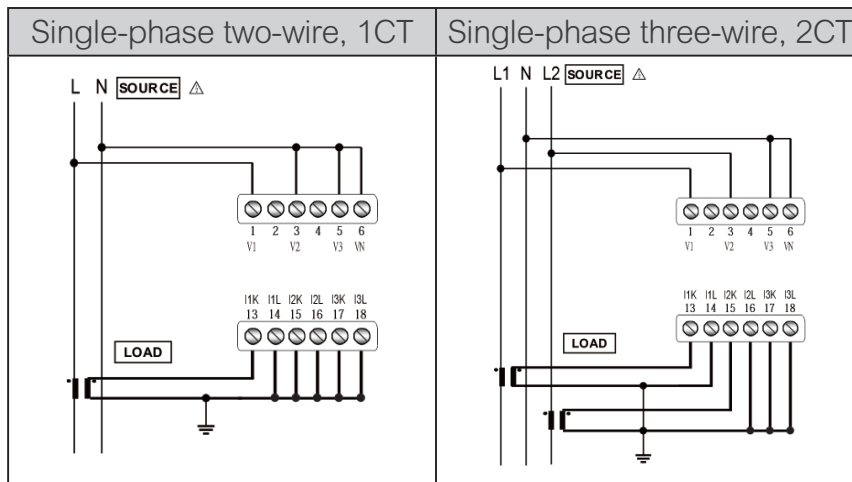

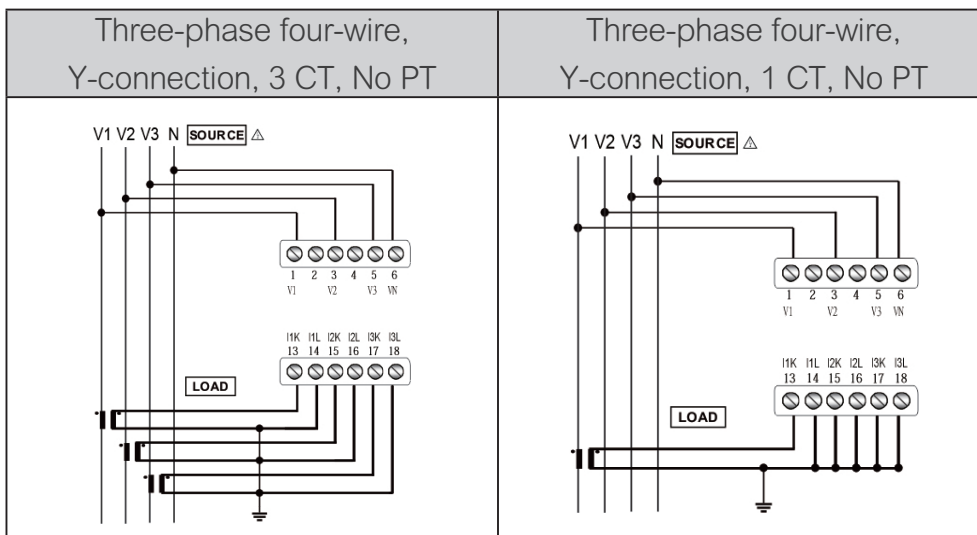
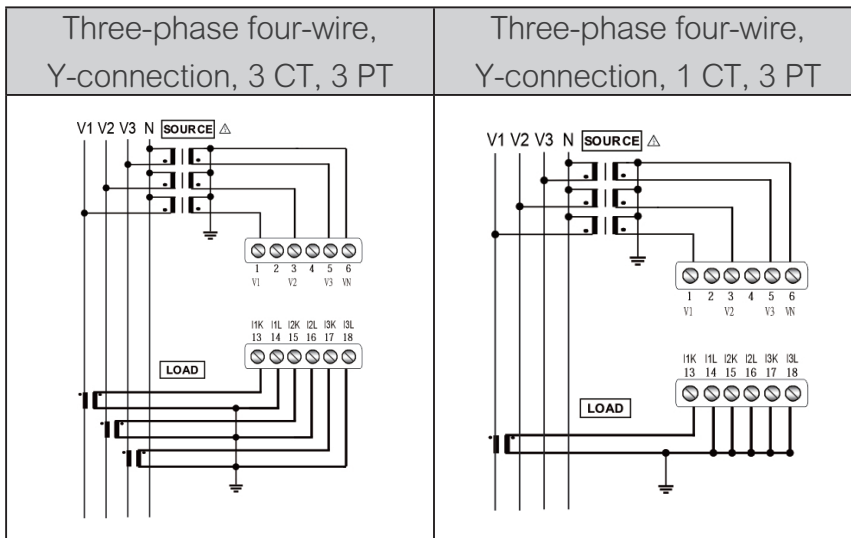
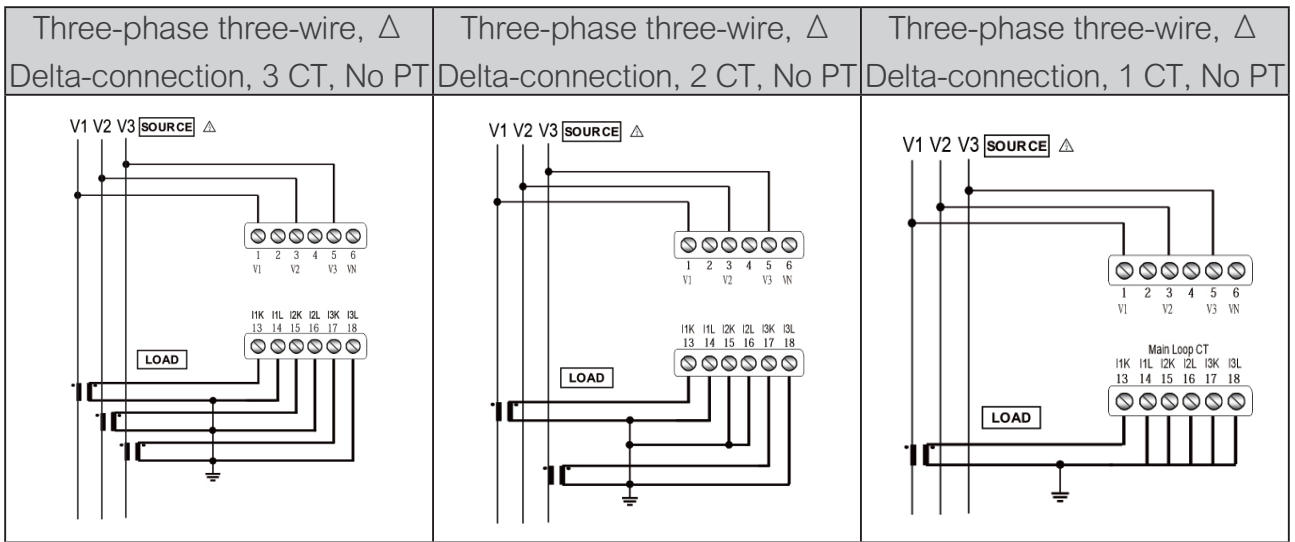

- PO connection
- RO connection

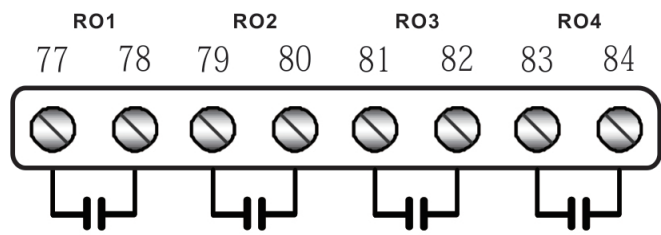
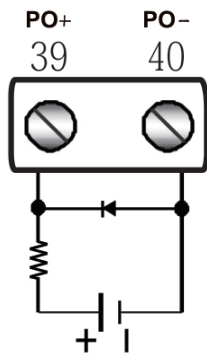

- DI connection

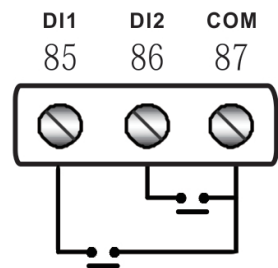

Figure symbol:

Symbol			
Description	GND	CT	PT

### 3.3.2 Communication Features

- Specification

Max distance of communication	1200 m	Baud Rate	1200、2400、4800、9600、19200、38400、57600、115200
Max number of connected stations	32	Data Bit	8
Communication Protocols	MODBUS RTU	Parity	None、Odd、Even
Functional Code	03, 06, 10	Stop Bit	1、2

- RS-485 cable must be twisted pair wires.
- D+ cables from the devices need to be connected with one twisted pair; D- cables from the devices need to be connected with another twist-pair. The isolation net should be grounding, and the terminal of the device needs to equipped with terminal resistance.
- Please use 28~14 AWG for wiring terminal.

# Chapter 4 Operation

## 4.1 General Operation

### 4.1.1 Reading Data

#### 4.1.1.1 Summary Page Inquire

Press UP or DOWN on the main screen to move the following pages.

- Summary-1 : measurement parameters of the specify loops including VLLavg, Iavg, Psum, and Freq.
- Summary-2 : measurement parameters of the specify loops including Psum, Qsum, Ssum, and PFavg.
- Summary-3 : measurement parameters of the v loops including VLLavg, Iavg, Psum, and PFavg.
- Summary-4 : measurement parameters of the specify loops including VLLavg, Iavg, Psum, and Freq.
- Summary-5 : measurement parameters of the specify loops including Psum, Qsum, Ssum, and PFavg.
- Summary-6 : measurement parameters of the specify loops including VLLavg, Iavg, Psum, and PFavg.
- Summary-P : measurement parameters of the specify loops. Users are able to set up the parameter showing on this page.

#### 4.1.1.2 Power Parameter Inquire

Press ENTER to enter the menu, select "Metering", and then press ENTER again.

Press LEFT to return to the previous page.

- Firstly, select voltage or the loop you need such as loop 1-3, loop 4-6, loop 7-9, loop 10-12, loop 13-15, loop 16-18, loop 19-21.
  - Phase Voltage : V1, V2, V3, Vavg
  - Line Voltage : U12, U23, U31, Uavg
  - Current : I1, I2, I3, Iavg, IN
  - Frequency
  - Power Factor : PF1, PF2, PF3, PFavg
  - Disp.PF : DPF1, DPF2, DPF3, DPFavg
  - Unbalance : V, I
  - Active Power : P1, P2, P3, Psum
  - Reactive Power : Q1, Q2, Q3, Qsum
  - Apparent Power : S1, S2, S3, Ssum
- ※ In the power measurement parameter page, due to display needs, the power unit will automatically change, such as W / VAR / VA, kW / kVAR / kVA or MW / MVAR / MVA.

- Total Harmonic : There are two types of parameters, fundamental(THD-F) and true RMS(THD-R) including V1, V2, V3, Vavg, I1, I2, I3, Iavg.
- Individual Harmonic : the 1st-31th harmonic distortion rate measurement parameters such as V1, V2, V3, I1, I2, I3.
- ※ Press UP or DOWN to check the percentage for each sub-harmonic.
- ※ Press LEFT to switch the scale of percentage display.
- ※ Press ENTER to switch data source: V1, V2, V3, I1, I2, I3
- ※ Press LEFT for 2 sec to return to the previous page.
- Demand : P, Q, S, I1, I2, I3, Iavg.
- MAX/MIN : Phase Voltage, Line Voltage, Current, Power, Frequency, Power Factor, THD-F of Voltage, THD-F of Current, Power Demand, Current Demand.
- ※ Demand only has max value.
- ※ On the page of MAN/MIN, please press UP for 2 sec to switch the parameters; the time stamp will be displayed at the bottom of the screen.
- ※ On the page of MAN/MIN, please press DOWN for 2 sec to switch MAX or MIN value.

#### 4.1.1.3 Energy Inquire

Press ENTER to enter the menu and select "Energy", and then press ENTER again to enter. Press LEFT to return to the previous page.

- Select the loop you need : loop 1-3, loop 4-6, loop 7-9, loop 10-12, loop 13-15, loop 16-18, loop 19-21, loop 1, loop 2, loop 3, loop 4, loop 5, loop 6, loop 7, loop 8, loop 9, loop 10, loop 11, loop 12, loop 13, loop 14, loop 15, loop 16, loop 17, loop 18, loop 19, loop 20, loop 21.
- Active Energy : import active energy (IMP), export active energy (EXP), total active energy (TOTAL), net active energy (NET).
- Reactive Energy : import reactive energy (IMP), export reactive energy (EXP), total reactive energy (TOTAL), net reactive energy (NET).
- Total Apparent Energy : total apparent energy (TOTAL)

#### 4.1.1.4 Alarm Inquire

Press ENTER to enter the menu and select "Alarm", and then press ENTER again to enter. Press LEFT to return to the previous page.

- Select the relay you need : Relay 1, Relay 2, Relay 3, Relay 4
- Select the parameter you need : Source, Loop, Object, Value, Set-Point, Mode.

### 4.1.2 Data Clear & Reset

Press ENTER to enter the menu and select "Clear & Reset", and then press ENTER again to enter. Please press LEFT to return to the previous page.

- Input the password : default 1000
- Select the loop you want to clear : all loop, loop 1-3, loop 4-6, loop 7-9, loop 10-12, loop 13-15, loop 16-18, loop 19-21, loop 1, loop 2, loop 3, loop 4, loop 5, loop 6, loop 7, loop 8, loop 9, loop 10, loop 11, loop 12, loop 13, loop 14, loop 15, loop 16, loop 17, loop 18, loop 19, loop 20, loop 21.
- Select the parameter you want to clear : clear all record except for MAX demand, all energy, all demand, all maximum demand, all MAX/MIN value, active energy, reactive energy, apparent energy, current demand, active power demand, reactive power demand, apparent power demand, max current demand, max active power demand, max reactive power demand, max apparent power demand.
- Press ENTER to enter the confirmation page, press UP or DOWN to select Yes, and then press ENTER to complete the data clear.

### 4.1.3 Meter Information

Press ENTER to enter the menu and select "Information", and then press ENTER again to enter. Please press LEFT to return to the previous page.

- Power Loop : Power phase, PT Primary/Secondary value, CT Primary/Secondary value, energy unit, loop voltage assign. The displayed content will vary depending on on the types of the loops.
- Communication : COM1, COM2, other communication interface
- Meter Information : Device, Loop

### 4.1.4 User Password

- Need to input the password when entering the page of "parameter settings" or "clear & reset". The default value is 1000.
- Steps of setup are as follows :
  1. Press UP or DOWN to select the first digit of the password.
  2. Press LEFT to move to the next digit of the password
  3. Repeat step 1 and 2 until finish the 4-digit of the password.
  4. Then press ENTER to enter parameter setting.
- ※ Return 4 zero to input again if the password is wrong ◦
- ※ Press LEFT and hold 2 sec can leave input page and return to the previous page.

## 4.1.5 General Setting

### 4.1.5.1 Wiring system

- System wiring can choose : single-phase two-wire (1P2W), single-phase three-wire (1P3W), three-phase three-wire 1CT (3P3W1CT), three-phase three-wire 2CT (3P3W2CT), three-phase three-wire 3CT (3P3W3CT), three-phase four-wire 1CT (3P4W1CT), three-phase Four-wire 3CT (3P4W3CT), the default setting is three-phase four-wire 3CT (3P4W3CT).
- Steps of setup are as follows :
  1. Press ENTER on the menu to enter the setting of the power system.
  2. Press UP or DOWN to select voltage or loops, and press ENTER.
  3. Press UP or DOWN to select the wiring mode.
  4. Press ENTER when finishing the setting and return to the previous page.
- ※ Press LEFT to cancel the setting and return to the previous page.
- ※ Each set of loops can set up the wiring system for measurement, but there will be restricted by the voltage phase connected.

Please see the table below :

Voltages phase	Loops phase			
	1P2W	1P3W	3P3W	3P4W
1P2W	○	X	X	X
1P3W	○	○	X	X
3P3W	○	X	○	X
3P4W	○	X	○	○

### 4.1.5.2 PT Setting

- PT Primary: The setting range is 0~9999k V, the default value is 600 V.
- PT Secondary: The setting range is 50~600 V, the default value is 600 V.
- Steps of setup are as follows :
  1. Press ENTER on the menu into PT/PRI voltage setting.
  2. Press UP or DOWN to select the numeric.
  3. Press LEFT to move to the next digit.
  4. Repeat step 2 to 3 when the setting of the voltage is done, then press ENTER to save, and return to the previous page.
  5. Press ENTER on the menu into PT/PRI voltage unit.
  6. Press UP or DOWN to select the unit, V or kV.
  7. Press ENTER to save, and return to the previous page.
  8. The voltage setting of PT/SEC is the same as PT/PRI.
- ※ Press LEFT and hold 2 sec can leave input page and return to the previous page.

#### 4.1.5.3 CT Setting

- CT Primary: The setting range is 5~9999 A, the default value is 5 A.
- CT Secondary: The setting range has 1 A or 5 A, the default value is 5 A.
- Steps of setup are as follows :
  1. Press ENTER on the menu into CT/PRI Ampere setting.
  2. Press UP or DOWN to select the loop, and press ENTER.
  3. Press UP or DOWN to select the numeric.
  4. Press LEFT to move to the next digit.
  5. Repeat step 3 to 4 until the ampere setting is done, and press ENTER to save and return to the previous page.
  6. Press ENTER on the menu into CT/SEC Ampere.
  7. Press UP or DOWN to select the ampere.
  8. Press ENTER to finish the setting and return to the previous page.
- ※ Press LEFT and hold 2 sec can leave input page and return to the previous page.

#### 4.1.5.4 Each Loop Voltage Phase Assign

- To obtain the power measurement & data, the loop can specify the phase voltage based on actual CT mounting, and measurement requirement.
- Steps of setup are as follows :
  1. Press ENTER on the menu into voltage assign setting.
  2. Press UP or DOWN to select the loop, and press ENTER.
  3. Press UP or DOWN to select the corresponding phase voltage of the loop.
  4. Press ENTER to finish the setting and return to the previous page.
- ※ Press LEFT to cancel the setting and return to the previous page.

#### 4.1.5.5 Modify Password

- The default value is 1000.
- Steps of setup are as follows :
  1. Press ENTER on the menu into the password setting.
  2. Press UP or DOWN to select the numeric.
  3. Press LEFT move to the next digit.
  4. Repeat step 2 to 3 until the setting is done, press ENTER to save and return to the previous page.
- ※ Press LEFT and hold 2 sec can leave input page and return to the previous page.

#### 4.1.5.6 Default Page

- Default Page : The setting range has Summary-1(VLLavg/lavg/Psum/Freq), Summary-2(Psum/Qsum/Ssum/PFavg), Summary-3(VLLavg/lavg/Psum/PFavg); the content of the summary-4/5/6 is the same as summary-1/2/3; summary 1-6 can select the corresponding loop individually; summary-P is a user-defined page, and able to set up the corresponding loop and required parameter. Also, the user can arrange all summary page showing on the screen.
- Steps of setup are as follows :
  1. Press ENTER on the menu page into the default page setting.
  2. Press UP or DOWN to select the page.
  3. Press ENTER to finish the setting and return to the previous page.
  4. Press ENTER into page loop select setting.
  5. Press UP or DOWN to select the page and press ENTER.
  6. Press UP or DOWN to select the corresponding loop for the selected loop.
  7. Press ENTER to finish the setting and return to the previous page.
  8. Press ENTER into the user page object setting.
  9. Press UP or DOWN to select the location and press ENTER.
  10. Press UP or DOWN to select the parameter showing on the location.
  11. Press ENTER to finish the setting and return to the previous page.
  12. Press ENTER into the rotate interval time setting.
  13. Press UP or DOWN to select the numeric.
  14. Press LEFT move to next digit.
  15. Repeat step 13 until time setting is done, and press ENTER to save and return to the previous page.
- ※ Press LEFT and hold 2 sec can leave input page and return to the previous page.

#### 4.1.6 Communcion

Firstly, select the port COM1 or COM2.

##### 4.1.6.1 Address

- Address setting : The set range is 1~247; broadcast is for 255, the default value is 1.
- Steps of setup are as follows :
  1. Press ENTER on the menu into the address setting.
  2. Press UP or DOWN to select the numeric.
  3. Press LEFT and move to the next digit.
  4. Repeat step 2 to 3 until the setting is done, and press ENTER to save and return to the previous page.
- ※ Press LEFT and hold 2 sec can leave input page and return to the previous page.

#### 4.1.6.2 Baudrate

- Baudrate setting : The set range is 1200 、 2400 、 4800 、 9600 、 19200 、 38400 、 57600 、 115200 bps, the default setting is 9600 bps.
- Steps of setup are as follows :
  1. Press ENTER on the menu into the baudrate setting.
  2. Press UP and DOWN to select required rate.
  3. Press ENTER to finish the setting and return to the previous page.
- ※ Press LEFT to cancel the setting and return to the previous page.

#### 4.1.6.3 Parity

- Parity check : The set range is N.8.1 、 N.8.2 、 O.8.1 、 E.8.1, the default setting is N.8.2.
- Steps of setup are as follows :
  1. Press ENTER on the menu into the parity setting.
  2. Press UP and DOWN to select required parity.
  3. Press ENTER to finish the setting and return to the previous page.
- ※ Press LEFT to cancel the setting and return to the previous page.

#### 4.1.6.4 Ethernet Setting

- If the 2nd port is Ethernet, the parameters that can be set to be DHCP, IP address, sub-mask IP and gateway IP. The communication protocol is Modbus TCP.
- The default IP address is 192.168.1.250, and DHCP is preset to enable.
- Steps of setup are as follows :
  1. Press ENTER on the menu into the DHCP setting.
  2. Press UP and DOWN to select enable or disable.
  3. Press ENTER to finish the setting and return to the previous page.
  4. Press ENTER into the IP Address setting.
  5. Press UP or DOWN to select the numeric.
  6. Press LEFT key move to the next digit.
  7. Repeat step 5 to 6 until the setting is done, and press ENTER to save and return to the previous page.
  8. Press ENTER into the subnet mask setting.
  9. The setting process is the same as IP address.
  10. Press ENTER into the gateway setting.
  11. The setting process is the same as IP address
- ※ Press LEFT and hold 2 sec can leave input page and return to the previous page.

#### 4.1.6.5 Module Control

- The communication module can be restarted, or reset to factory default with control function.
- It must be restarted by the module when the parameter of Ethernet is updated
- Steps of setup are as follows :
  1. Press ENTER on the menu into Force Reboot.
  2. Press UP and DOWN to select Yes or No.
  3. Press ENTER to finish the setting and return to the previous page.
  4. Press ENTER into the Set to Default.
  5. Press UP and DOWN to select Yes or No.
  6. Press ENTER to finish the setting and return to the previous page.
- ※ Press LEFT to cancel the setting and return to the previous page.

#### 4.1.7 Pulse Output

##### 4.1.7.1 Test Pulse

- The test pulse output can be set to be enabled or disabled, the default setting is disabled. The pulse output is fixed at 3200 Pulse / 1kWh, and the duty cycle is 50%.
- Steps of setup are as follows :
  1. Press ENTER on the menu into the test pulse setting.
  2. Press UP and DOWN to select enable or disable.
  3. Press ENTER to finish the setting and return to the previous page.
- ※ Press LEFT to cancel the setting and return to the previous page.

##### 4.1.7.2 Target Loop

- Select the loop corresponding to the pulse output, the default setting is loop 1-3.
- Steps of setup are as follows :
  1. Press ENTER on the menu into the target loop setting.
  2. Press UP and DOWN to select the loop.
  3. Press ENTER to finish the setting and return to the previous page.
- ※ Press LEFT to cancel the setting and return to the previous page.

#### 4.1.7.3 Energy Type

- Select the corresponding energy parameters to pulse output. The selectable parameters include Import kWh, Export kWh, Import kVARh, Export kVARh, and OFF, the default setting is Import kWh.
- Steps of setup are as follows :
  1. Press ENTER on the menu into the energy type setting.
  2. Press UP and DOWN to select the corresponding energy parameter.
  3. Press ENTER to finish the setting and return to the previous page.
- ※ Press LEFT to cancel the setting and return to the previous page.

#### 4.1.7.4 Pre-Divider

- Pre-Divider setting: The set range is 1 ~ 9999, the default value is 1.
- Steps of setup are as follows :
  1. Press ENTER on the menu into the pre-divider setting.
  2. Press UP or DOWN to select the numeric.
  3. Press LEFT move to the next digit.
  4. Repeat step 2 to 3 until the setting is done, and press ENTER to save and return to the previous page.
- ※ Press LEFT and hold 2 sec can leave input page and return to the previous page.

#### 4.1.7.5 Time of Level High

- Pulse output high level time setting : The setting range is 0 ~ 5000 mS, 0 means 50% duty of the high and low level, the default value is 0.
- Steps of setup are as follows :
  1. Press ENTER on the menu into the high time setting.
  2. Press UP or DOWN to select the numeric
  3. Press LEFT move to the next digit.
  4. Repeat step 2 to 3 until the setting is done, and press ENTER to save and return to the previous page.
- ※ Press LEFT and hold 2 sec can leave input page and return to the previous page.

#### 4.1.8 Energy Unit

- Setting of energy unit : The setting range is 0.0001kWh, 0.001kWh, 0.01kWh, 0.1kWh, 1kWh, 0.01MWh, or 0.1MWh, the default setting is 0.1kWh.
- Steps of setup are as follows :
  1. Press ENTER on the menu into the energy unit setting.
  2. Press UP or DOWN to select energy unit.
  3. Press ENTER to finish the setting and return to the previous page.
- ※ Press LEFT to cancel the setting and return to the previous page.

## 4.1.9 Date/Time

### 4.1.9.1 Backlight Time

- LCM backlight time setting: The setting range is 0 ~ 15 minutes, 0 means the light always on, the default value is 1.
- Steps of setup are as follows :
  1. Press ENTER on the menu into the backlight time setting.
  2. Press UP or DOWN to select the numeric.
  3. Press LEFT move to the next digit.
  4. Repeat step 2 to 3 until the setting is done, and press ENTER to save and return to the previous page.
- ※ Press LEFT and hold 2 sec can leave input page and return to the previous page.

### 4.1.9.2 Date

- Date setting : The setting range is 2010/1/1 ~ 2099/12/31
- Steps of setup are as follows :
  1. Press ENTER on the menu into the date setting.
  2. Press UP or DOWN to select the numeric.
  3. Press LEFT key move to the next digit.
  4. Repeat step 2 to 3 until the setting is done, and press ENTER to save and return to the previous page.
- ※ Press LEFT and hold 2 sec can leave input page and return to the previous page.

### 4.1.9.3 Time

- Time setting : The setting range is 00: 00: 00 ~ 23: 59: 59.
- Steps of setup are as follows :
  1. Press ENTER on the menu into the time setting.
  2. Press UP or DOWN to select the numeric.
  3. Press LEFT key move to the next digit.
  4. Repeat step 2 to 3 until the setting is done, and press ENTER to save and return to the previous page.
- ※ Press LEFT and hold 2 sec can leave input page and return to the previous page.

### 4.1.9.4 Operation Hour Reset

- Reset the operating hour.
- Steps of setup are as follows :
  1. Press ENTER on the menu into the operation hour reset.
  2. Press UP and DOWN to select “YES” to clear data, or “NO” to leave.
  3. Press ENTER to finish the setting and return to the previous page.
- ※ Press LEFT to cancel the setting and return to the previous page.
- ※ The operation hour will start accruing when the meter power on.

#### 4.1.9.5 Running Hour Reset

- Reset the running hour.
- Steps of setup are as follows :
  1. Press ENTER on the menu into the running hour reset.
  2. Press UP and DOWN to select “YES” to clear data, or “NO” to leave.
  3. Press ENTER to finish the setting and return to the previous page.
- ※ Press LEFT to cancel the setting and return to the previous page.
- ※ The running hour starts accruing when the current input value exceeds 1% of the rated value.

#### 4.1.10 Demand

##### 4.1.10.1 Mode

- Setting of demand calculation mode : Can be set to sliding block or fixed block, the default setting is sliding block.
- Steps of setup are as follows :
  1. Press ENTER on the menu into the mode setting.
  2. Press UP and DOWN to select demand mode.
  3. Press ENTER to finish the setting and return to the previous page.
- ※ Press LEFT to cancel the setting and return to the previous page.

##### 4.1.10.2 Period

- Setting of calculation period time setting : The setting range is 1 ~ 60 minutes, the default value is 15 minutes.
- Steps of setup are as follows :
  1. Press ENTER on the menu into the period setting.
  2. Press UP or DOWN to select the numeric.
  3. Press LEFT key move to the next digit.
  4. Repeat step 2 to 3 until the setting is done, and press ENTER to save and return to the previous page.
- ※ Press LEFT and hold 2 sec can leave input page and return to the previous page.

#### 4.1.11 Input/Output

##### 4.1.11.1 Digital Input

- Meter has two digital input : DI1 \ DI2 ◦
- In addition, digital input can also be used as: Demand Reset, MAX Demand Reset, Energy Reset, MAX/MIN Reset, and Relay Reset, the default setting is DI.
- Trigger level can be set to ON or OFF.
- Debounce Time : The setting range is 0~99 ( x 8mS), the factory default value is 5 which means 40mS.

- Each digital input can set function respectively, and the setting methods are the same.
- Steps of setup are as follows :
  1. Press ENTER on the menu into the function mode setting.
  2. Press UP and DOWN to select the function mode.
  3. Press ENTER to finish the setting and return to the previous page.
  4. Press ENTER into the trigger state setting.
  5. Press UP or DOWN to select ON or OFF.
  6. Press ENTER to finish the setting and return to the previous page.
  7. Press ENTER into the debounce time setting.
  8. Press UP or DOWN to select the numeric.
  9. Press LEFT key move to the next digit.
  10. Repeat step 8 to 9 until the setting is done, and press ENTER to save and return to the previous page.
- ※ Press LEFT and hold 2 sec can leave input page and return to the previous page.

#### 4.1.11.2 Relay Output

- Meter has four relay output ports : RO1, RO2, RO3, RO4.
- In addition, relay output can be set to alarm mode, the default setting is RO.
- In alarm mode, It can be set as Active Delay Time, the setting range is 0~5999 (x 0.1S), and the factory default value is 0.
- Able to set 12 groups of alarm : Alarm Mode, Loop, Object, Set Point.
- The action mode of the relays : Low, High, Low and Hold, High and Hold, and Off. If set the relay in action and hold mode, DI needs to be set as relay reset so that the relay can be reset through the DI input.
- The corresponding parameters to the relay in alarm mode : Frequency, Phase Vavg, Line Vavg, Current, Active Power, Reactive Power, Apparent Power, Power Factor, Demand Current, Demand Power P, Demand Power Q, Demand Power S.
- These four relay output can set function respectively, and the setting methods are the same.
- Steps of setup are as follows :
  1. Press ENTER on the menu into the function mode setting.
  2. Press UP and DOWN to select function mode.
  3. Press ENTER to finish the setting and return to the previous page.
  4. Press ENTER into the active delay time setting.
  5. Press UP or DOWN to select the numeric.
  6. Press LEFT key move to the next digit.
  7. Repeat step 5 to 6 until the setting is done, and press ENTER to save and return to the previous page.
  8. Press ENTER on the menu into the alarm setting.

9. Press UP or DOWN to select the group of the alarm condition.
  10. Press ENTER to enter the setting of the alarm conditional.
  11. Press ENTER into the alarm mode setting.
  12. Press UP and DOWN to select alarm mode.
  13. Press ENTER to finish the setting and return to the previous page.
  14. Press ENTER into the loop setting.
  15. Press UP and DOWN key to select the loop.
  16. Press ENTER to finish the setting and return to the previous page.
  17. Press ENTER into the object setting.
  18. Press UP and DOWN to select the parameter.
  19. Press ENTER to finish the setting and return to the previous page.
  20. Press ENTER into the set point setting.
  21. Press UP or DOWN to select the numeric.
  22. Press LEFT move to the next digit.
  23. Repeat step 21 to 22 until the setting is done, and press ENTER to save and return to the previous page.
- ※ Press LEFT and hold 2 sec can leave input page and return to the previous page.

#### 4.1.12 Initial

- Reset the power meter to factory default value, the password is 7170.
  - Steps of setup are as follows :
    1. Press ENTER on the menu into the initial default.
    2. Press UP or DOWN to select the numeric.
    3. Press LEFT move to the next digit.
    4. Repeat step 2 to 3 until the input is done, and press ENTER to initial.
- ※ Press LEFT and hold 2 sec can leave input page and return to the previous page.
- ※ The meter will restart when initial starts operating.

## 4.2 Measurement algorithm

### 4.2.1 Harmonic

Total Harmonic Distortion (THD) is the current detection of waveform distortion. The calculation method is divided into fundamental wave and true RMS value, which is the ratio of harmonic content to fundamental wave or true RMS value. The calculation formula of voltage/current total harmonic distortion is:

Fundamental (THD-F):

Current Total Harmonic Distortion:	$THD_I = \frac{1}{ I_{fund} } \sqrt{\sum_{n=2}^{31}  I_{n.Harm} ^2}$
Voltage Total Harmonic Distortion:	$THD_U = \frac{1}{ U_{fund} } \sqrt{\sum_{n=2}^{31}  U_{n.Harm} ^2}$

Ture RMS(THD-R):

Current Total Harmonic Distortion:	$THD_i = \frac{1}{\sqrt{\sum_{n=1}^{31}  I_{n.Harm} ^2}} \sqrt{\sum_{n=2}^{31}  I_{n.Harm} ^2}$
Voltage Total Harmonic Distortion:	$THD_v = \frac{1}{\sqrt{\sum_{n=1}^{31}  U_{n.Harm} ^2}} \sqrt{\sum_{n=2}^{31}  U_{n.Harm} ^2}$

## 4.2.2 Demand

This demand calculation measured by the meter includes active power demand, reactive power demand, apparent power demand, three phase current demand and average current demand. The calculation method is as follows:

### 4.2.2.1 Sliding Block

When using the sliding block interval method, user selects an interval from 1 to 60 minutes, which is the period of the calculation. The demand updates every 1 minute as the block slides once. The following example is a figure for 15-minute block interval:

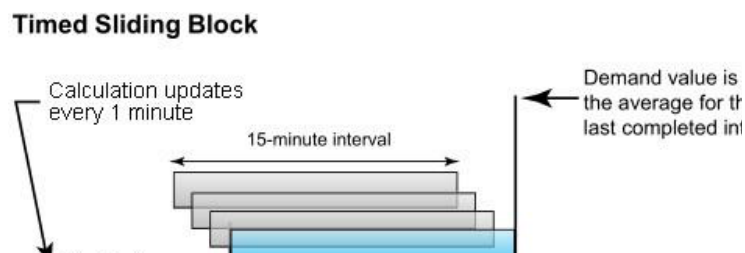

### 4.2.2.2 Fix Block

Like the sliding block, a calculation period is set first, and the increment is also one minute. However, only one demand is calculated in the whole period. So the interval of the demand update is the calculation of the cycle time. The following example is a figure for 15-minute block interval:

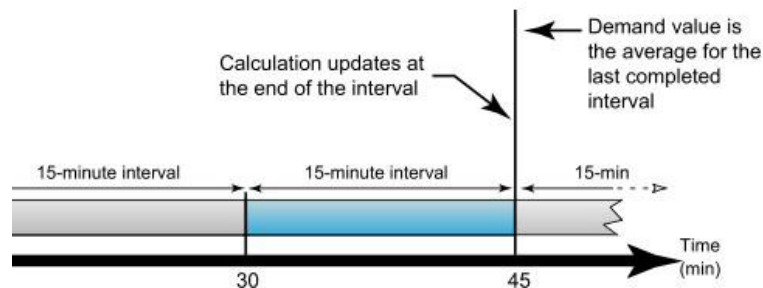

### 4.3 Block transfer function

This function is designed to let the user collect all the parameter, and read them at one time.

Fill the parameters in the address of 0x5000~0x504F in sequence, and then you can read the value of the corresponding parameters from the address of 0x5100~0x514F.

Please refer to the communication address table for the selected set range.

For example:

If 0x5000 is written in 0x1001 (high byte address of V1 voltage); 0x5001 is written in 0x1002 (low byte address of V1 voltage), reading the value of 0x5100 and 0x5101 is the V1 voltage.

### 4.4 Data Log

In order to help users view the historical reads, the meter provides the function of data logging.

The meter is equipped with data storage capacity of 2MB for data recording. It has a real-time clock (RTC) and each data log has a time stamp.

#### 4.4.1 Setting of Data Logging

The data logging can set up to 59 parameters according to users requirement, 59 types of parameters can be recorded. Please see Table 4-1.

Table 4-1

No.	Parameter	No.	Parameter	No.	Parameter	No.	Parameter	No.	Parameter
0	NONE	1	Frequency	2	Phase voltage average	3	Line voltage average	4	Loop 1-3 Current average
5	Loop 1-3 Total active power	6	Loop 1-3 Total reactive power	7	Loop 1-3 Total apparent power	8	Loop 1-3 Power factor average	9	Loop 1-3 Import active energy
10	Loop 1-3 Import reactive energy	11	Loop 1-3 Total apparent energy	12	Loop 4-6 Current average	13	Loop 4-6 Total active power	14	Loop 4-6 Total reactive power
15	Loop 4-6 Total apparent power	16	Loop 4-6 Power factor average	17	Loop 4-6 Import active energy	18	Loop 4-6 Import reactive energy	19	Loop 4-6 Total apparent energy
20	Loop 7-9 Current average	21	Loop 7-9 Total active power	22	Loop 7-9 Total reactive power	23	Loop 7-9 Total apparent power	24	Loop 7-9 Power factor average

25	Loop 7-9 Import active energy	26	Loop 7-9 Import reactive energy	27	Loop 7-9 Total apparent energy	28	Loop 10-12 Current average	29	Loop 10-12 Total active power
30	Loop 10-12 Total reactive power	31	Loop 10-12 Total apparent power	32	Loop 10-12 Power factor average	33	Loop 10-12 Import active energy	34	Loop 10-12 Import reactive energy
35	Loop 10-12 Total apparent energy	36	Loop 13-15 Current average	37	Loop 13-15 Total active power	38	Loop 13-15 Total reactive power	39	Loop 13-15 Total apparent power
40	Loop 13-15 Power factor average	41	Loop 13-15 Import active energy	42	Loop 13-15 Import reactive energy	43	Loop 13-15 Total apparent energy	44	Loop 16-18 Current average
45	Loop 16-18 Total active power	46	Loop 16-18 Total reactive power	47	Loop 16-18 Total apparent power	48	Loop 16-18 Power factor average	49	Loop 16-18 Import active energy
50	Loop 16-18 Import reactive energy	51	Loop 16-18 Total apparent energy	52	Loop 19-21 Current average	53	Loop 19-21 Total active power	54	Loop 19-21 Total reactive power
55	Loop 19-21 Total apparent power	56	Loop 19-21 Power factor average	57	Loop 19-21 Import active energy	58	Loop 19-21 Import reactive energy	59	Loop 19-21 Total apparent energy

Please see Table 4-2 for the time parameters requested by the data logging.

Table 4-2

Hex	Item	Size	Data Format	Range	Unit	Default	R / W	Notes
0x4010	FLASH remaining time	1	INT16U	0~65535			R / W	
0x4011	Logging interval time	1	INT16U	1~32767		15	R / W	
0x4012	Unit of interval time	1	INT16U	0: sec 1: min 2: hour 3: day		1	R / W	
0x4013	Date and time for start	1	INT16U	2020~2099	Year		R / W	
0x4014		1	INT16U	1~23	Month		R / W	
0x4015		1	INT16U	1~31	Day		R / W	
0x4016		1	INT16U	0~23	Hour		R / W	
0x4017		1	INT16U	0~59	Minute		R / W	
0x4018		1	INT16U	00~59	Second		R / W	
0x4019	Date and time for stop	1	INT16U	2020~2099	Year		R / W	
0x401A		1	INT16U	1~23	Month		R / W	
0x401B		1	INT16U	1~31	Day		R / W	
0x401C		1	INT16U	0~23	Hour		R / W	
0x401D		1	INT16U	0~59	Minute		R / W	
0x401E		1	INT16U	00~59	Second		R / W	
0x401F	Logging enable	1	INT16U	0: Disable 1: Enable			R / W	
0x4020	Log.01	1	INT16U	See table 4-1		0	R / W	
0x4021	Log.02	1	INT16U	See table 4-1		0	R / W	
:	:							
0x4059	Log.58	1	INT16U	See table 4-1		0	R / W	
0x405A	Log.59	1	INT16U	See table 4-1		0	R / W	

FLASH remaining time: The remaining time until the data memory is full, the unit of reading is minutes.

Recording interval duration time: can set any integer between 1 ~ 32767.

Unit of recorded interval duration: can set to be second, minute, hour, and day.

Record period: set the start time and end time. The set range is from year, month, day, hour, minute and second. Once it starts running, data log will record the data at each time interval.

Note: Any incomplete or incorrect settings will result in the recorded failure. All the setting is operated by the corresponding register. Also, the settings of the registers must go through the communication port. Once the record capacity is full, the meter will overwrite the data by replacing old files with new ones. Therefore, user are advised to read and save the entire data record before the storage pool is full.

Any updates on the content of recorded parameter will restart the meter recoding and old data will not be keep.

#### 4.4.2 Reading Data log

Reading data log must go through communication port.

Table 4-3

Hex	Item	Size	Data Format	Range	Unit	Default	R / W	Notes
0x4000	Byte count of each recording	1	INT16U	1~255			R	
0x4001	Number of unread data	1	INT16U	0~65535			R	
0x4002	Data read	1	INT16U	Reply 0x20 if data empty			R	
0x4003	Status reply after read	1	INT16U	0: Clear logging data (Index reset) 1: Abort this time read (Index will not any shift) 2: Read success			W	

The length of the data will be read by the address (0x4000); and the content will be read by the address (0x4002).

Shown as below :

Request:

Address	Code	Starting Reg		Byte count		CRC	
		Hi	Lo	Hi	Lo	LO	Hi
01h	03h	40h	00h	xxh	xxh	xxh	xxh

Byte count: Read from 0x4000

The data content will be sent as below:

Response:

Address	Code	Byte Count	Year		Month		Day		Hour		Minute		Second		Data	CRC	
			Hi	Lo	Hi	Lo	Hi	Lo	Hi	Lo	Hi	Lo	Hi	Lo		Lo	Hi
01h	03h	30h	07h	DFh	00h	0Ch	00h	01h	00h	0Dh	00h	19h	00h	2Ah	.....	xxh	xxh

Byte Count: Read from 4000h

Date: 2015/12/01 (07DFH/000CH/001H)

Time: 13:25:42 (000DH:0019H:003AH)

One read command sent can only receive a log record. (0x4001) shows the number unread data records; 0020h means all data records have been read.

The address (0x4003) will report back to the meter after reading a data record, so it can be a reference of record shift log. Also, the user can clear the data record, or give up on reading the data record when the address (0x4003) report back the meter.

## 4.5 TOU

User can divide the time into to 4 Time Of Use (TOU) tariffs( sharp, peak, valley and normal). The meter will calculate and accumulate the energy at different tariffs according to the setting.

TOU setting: User can set up to 4 seasons. Each season can be assigned to a TOU schedule, maximum of 8 TOU schedules are available. Each schedule can be divided up into 8 segments, each segment can have its own tariff (sharp, peak, valley and normal).

User can customize the TOU calendar (including its tariffs, seasons, schedules and segments) according to different applications. To make sure that the TOU calendar is setup correctly, the meter will check the TOU settings according to the predefined rules.

TOU function will be disabled if the TOU calendar is set up incorrectly. If no errors are found in the calendar and the TOU function is enabled, TOU energy accumulation will begin.

### 4.5.1 Season Setting

The calendar year will be divided into different seasons depending on the season setting parameter. The parameter can be selected from any integer between 1 to 4. User must enter the correct value for the season setting parameter in accordance to the TOU season table. If the season setting parameter is set as 2, the first 2 slots of the TOU season table must be set, otherwise it will be considered as an invalid input, TOU function will be disabled.

## 4.5.2 TOU Season Format

XX month-XX day, X day timetable, the time zone setting must be done in a closed loop structure, otherwise it will be regarded as an error.

For example, three time zones are selected, the first time zone is set to January 1st 1 time slot table, the second time zone is set to June 6th 2 time slot table, and the third time zone is set to September 7th 3 time slot table. If the first time zone is set to January 1st 1 timetable, the second time zone is set to September 7th 2 timetables, and the third time zone is set to June 6th 3 timetables, it will be regarded as an error.

## 4.5.3 Schedule Setting

The setting parameter of the daily timetable is an integer between 1 and 8. After the number of daily timetables is set, the day timetable in the daily timetable will be set in descending order according to the setting parameters of the daily timetable.

The function of the daily timetable is to preset each time zone of the day and the corresponding rate, so up to 8 timetables can be preset for 4 time zones to apply.

## 4.5.4 Segment Setting

The setting parameter of the number of day periods is an integer between 1 and 8, that is, a day can be divided into 8 periods at most. After the setting of the number of time periods of the day is completed, the parameters of the day time period will be set in the daily time period table according to the number of days. The setting format of the daily time slot is XX hour-XX minutes, X rate, and the daily time slot setting is in the order of from small to large. Note that the daily time slot setting must be closed loop production, otherwise it will be regarded as a production error.

## 4.5.5 Tariff Setting

This parameter corresponds to the number of tariffs available for the TOU calendar and can be selected from any integer from 0 to 3. The four tariffs: sharp, peak, valley and normal are represented by 4 integers: 0,1,2 and 3 respectively.

## 4.5.6 Holiday Setting

This parameter can be set from any integer between 0 and 20, meaning a maximum of 20 holidays can be programmed to the TOU calendar. If the holiday setting parameter is set as 3, the first 3 slots of the holiday schedule must be set, otherwise it will be considered as an invalid input, TOU function will be disabled.

Note: User can reset the TOU calendar to default value via communication.

### 4.5.7 Holiday Schedule

The holiday schedule uses the same format as the TOU seasons “MM-DD ID” . User can select which TOU schedule to be used for the holiday. The dates of the holiday schedule do not need to be organized in a sequential order (i.e. the first slot can be January 1, the second slot can be December 26 and the third slot can be December 25).

Holiday day can be set to use the same holiday day setting for the next 5 years, or 5 years holiday day can be setting separately. When multi-year holiday function is enabled, if the current year of the meter falls into the multi-year holiday setting, it automatically loads the multi-year holiday settings into the current TOU settings. If the current year of the meter does not fall into the multi-year holiday setting, it remains the current TOU settings.

Note: Holiday schedule has the highest priority among all the schedules.

### 4.5.8 Weekend Schedule

Weekend setting: Definition of weekend is fixed as Saturday and Sunday. When the meter clock is within the Weekend Schedule, the energy will accumulate under the tariff that corresponds to the Schedule.

Note: Weekend schedule's priority is followed by Holiday schedule. When Holiday schedule is not enabled, Weekend schedule has the highest priority, overriding the normal (weekday) schedule.

### 4.5.9 Demand

TOU can record maximum power and current demand under different tariffs, as well as the time stamp of the maximum value. It can also clear by setting the corresponding register or from the meter front.

### 4.5.10 Settlement

In TOU, the settlement of electric energy can be done in two ways:

Method 1: Settle the electric energy in the way of the end of the natural month, that is, save the electric energy value of the current month to the corresponding space of the electric energy of the previous month at 0:00:00 on the 1st of each month.

Method 2: Settlement of electric energy according to the set day, that is, when the value of XX day XX hour XX minute XX second of the electric meter operation is the same as the set value of the electric meter, the electric energy value of the current month is saved to the corresponding space of the electric energy of the previous month.

# Chapter 5 Troubleshooting

## 5.1 Common Malfunction Analysis

### 5.1.1 Power meter doesn't work after power on

- Make sure voltage and other wiring is correct, voltage should be in the future functional range
- Turn off meter and start again.

### 5.1.2 Voltage or current reading is incorrect

- Check the wiring mode settings match the actual wiring mode.
- Check the voltage potential transformer (PT) and current transformer (CT) variable ratio are set correctly.
- Check the GND is correctly grounded.
- Check the voltage potential transformer (PT) and current transformer (CT) are intact.

### 5.1.3 Power or power factor reading is incorrect, but voltage and current are correct

- Compare the voltage and current input of the inter-wiring and wiring diagram to check whether the phase relationship is correct.

### 5.1.4 RS-485 Communication abnormal

- Check the communication baud rate, ID and communication protocol settings of the upper machine are consistent with the meter.
- Please check whether the data bit, stop bit, check bit settings are consistent with the host computer.
- Check if RS-485 converter is working.
- Check whether there is any problem with the entire communication line (short circuit, open circuit, grounding, whether the shield wire is correctly grounded at single-end, etc.).
- Turn off the meter and host computer, and then restart.
- For long communication lines, it is recommended that a matching resistance of about 120 ohms be connected in parallel at the end of the communication line.