

Miniature Indicator(24x48mm)



DESCRIPTION

CS3-PR Process Indicator has been designed in miniature size(24 x 48mm), and provide high accuracy 0.04% measurement, display and communication of DC signal 0~10V and 4(0)~20mA.

They are also to build 2 Relay outputs, 1 External Control Input, 1 Analogue output or 1 RS485(Modbus RTU Mode) interface with versatile functions such as control, alarm, re-transmission or communication.

FEATURE

- Measuring linear signal 0~10V / 0(4)~20mA(with Square Root function) in one controller
- 2 relay can be programmed individual to be a Hi / Lo / Hi Latch / Lo Latch energized with Start Delay / Hysteresis / Energized & De-energized Delay functions, or to be a remote control.
- Analogue output or RS 485 communication port available in option
- 1 external control input can be programmed to be Relative PV(Tare) / PV Hold / DI (remote monitoring) / Reset for Maximum or Minimum Hold / Reset for Relay Energized Latch....
- CE Approved

APPLICATIONS

Process control, alarm and monitoring
Test equipments

Machinery indication, control and alarm
Central monitoring panel

ORDERING INFORMATION

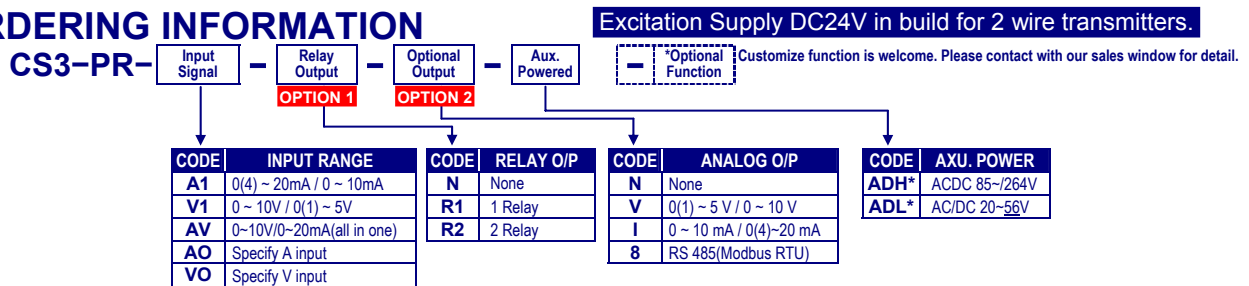

TECHNICAL SPECIFICATION

Input

Measuring Range	Input Impedance	Measuring Range	Input Impedance
Voltage 0 ~ 10 V	≥ 1M ohm	Current 4(0)~20 mA	250 ohm

> The Meter can be 0~10V and 0~20mA in one unit, according to connection #1 or #2

Calibration: Digital calibration by front key
A/D converter: 16 bits resolution
Accuracy: ≤ ± 0.04% of FS ± 1C;
Sampling rate: 15 cycles/sec
Response time: ≤ 100 msec.(when the AvG = "1") in standard
Input type: 0~10V / 0~5V / 1~5V / 0~10mA / 0~20mA / 4~20mA programmable for coding AV(option)
Input range: Input High and Low programmable with square root function
 Ai.Hi: Settable range: 0.00~100.00% of input range
 Ai.Lo: Settable range: 0.00~100.00% of input range

Display & Functions

LED: Numeric: 5 digits, 0.4"(10.0mm)H red high-brightness LED
 Relay output indication: 2 square red LED
 RS 485 communication: 1 square orange LED
 E.C.I. function indication: 1 square green LED
 -19999~+29999;
Display range: Lo.SC: Low Scale; Settable range: -19999~+29999
 Hi.SC: High Scale; Settable range: -19999~+29999
 Programmable from 0 / 0.0 / 0.00 / 0.000 / 0.0000
Over range indication: ovFL, when input is over 20% of input range Hi
Under range indication: -ovFL, when input is under 20% of input range Lo
Max / Mini recording: Maximum and Minimum value storage during power on.
Display functions: PV / Max(Mini) Hold / RS 485 programmable
Front key functions: Up key can be set to be a function as ECI.1
Low cut: Settable range: -19999~29999 counts
 Pv.Zro: Settable range: -19999~+29999
 Pv.SPn: Settable range: -19999~+29999

Reading Stable Function

Average: Settable range: 1~99 times
Moving average: Settable range: 1(None)~10 times
Digital Filter: Settable range: 0(None)/1~99 times

Control Functions(option)

Set points: Two set-points
Control relay: 2 Relays FORM-C, 1A/230Vac, 3A/115V
Relay energized mode: Energized levels compare with set-points:
 Hi / Lo / Hi.HLD / Lo.HLD programmable
Energized by RS485 command of master: DO programmable
Energized functions: Start delay / Energized & De-energized delay / Hysteresis
 Energized Latch
Start band(Minimum level for Energizing): 0~9999counts
Start delay time: 0.00.0~9(Minutes):59.9(Second)
Energized delay time: 0.00.0~9(Minutes):59.9(Second)
De-energized delay time: 0.00.0~9(Minutes):59.9(Second)
 Hysteresis: 0~5000 counts

External Control Inputs(ECI)

Input mode: 1 ECI points, Contact or open collect input, Level trigger
Functions: Relative PV(Tare) / PV Hold / Reset for Max or Mini. Hold / DI / Reset for Relay Energized latch
Debouncing time: Settable range 5 ~255 x 8m seconds

Analogue output(option)

Accuracy: ≤±0.1% of F.S.;
Ripple: ≤± 0.1% of F.S.
Response time: ≤100 msec. (10~90% of input)
Isolation: AC 1.5 KV between input and output
Output range: Specify either Voltage or Current output in ordering
 Voltage: 0~5V / 0~10V / 1~5V programmable
 Current: 0~10mA / 0~20mA / 4~20mA programmable
Output capability: Voltage: 0~10V: ≥ 1000Ω;
 Current: 4(0)~20mA: ≤ 600Ω max

Functions:

Ao.HS(output range high): Settable range: -19999~29999
Ao.LS(output range Low): Settable range: -19999~29999
Ao.LMt(output High Limit): 0.00~110.00% of output High
Ao.Zro: Settable range: -38011~+27524
Ao.SPn: Settable range: -38011~+27524

Digital fine adjust:

RS 485 communication(option)

Protocol: Modbus RTU mode
Baud rate: 1200/2400/4800/9600/19200/38400 programmable
Data bits: 8 bit
Parity: Even, odd or none (with 1 or 2 stop bit) programmable
Device no.: 1 ~ 255 programmable
Remote display: to show the value from RS485 command of master
Distance: 1200M
Terminate resistor: 150Ω at last unit.

Electrical Safety

Dielectric strength: AC 1.5 KV for 1 min, Between Power / Input / Output / Case
Insulation resistance: ≥ 100M ohm at 500Vdc, Between Power / Input / Output
Isolation: Between Power / Input / Relay / E.C.I./ Analogue or RS485
EMC: EN 55011:2002; EN 61326:2003
Safety(LVD): EN 61010-1:2001

Environmental

Operating temp.: 0~60 °C
Operating humi.(%RH): 20~95 %RH, Non-condensing
Temp. coefficient: ≤100 PPM/°C
Storage temperature: -10~70 °C
Enclosure: Front panel: IEC 549 (IP54); Housing: IP20

Mechanical

Dimensions: 48mm(W) x 24mm(H) x 102mm(D)
Panel cutout: 45mm(W) x 22.5mm(H)
Case material: ABS fire-protection (UL 94V-0)
Mounting: Panel flush mounting
Terminal block: Plastic NYLON 66 (UL 94V-0)
 5A 300Vac, M2.0, 0.5~1.3mm²(22~16AWG)
Weight: About 110g

Power

Power supply: AC/DC 85~264V or AC/DC 20~56V
Excitation supply: DC 24V, 30mA maximum in standard
Power consumption: 4.5VA max.
Back up memory: By EEPROM

FRONT PANEL

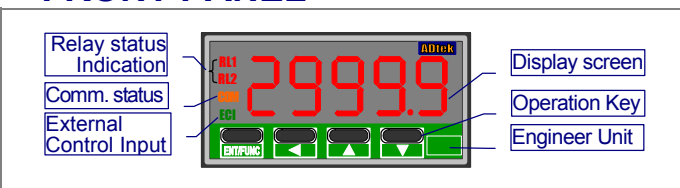

DIMENSIONS

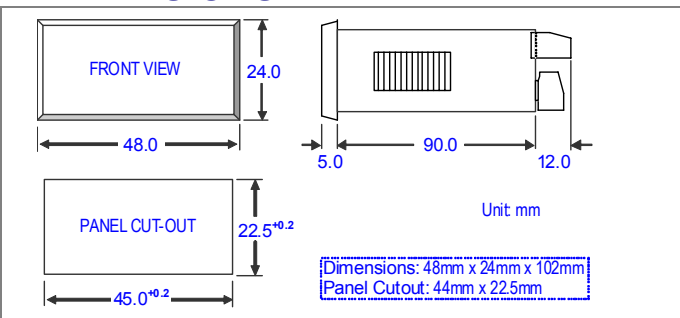

INSTALLATION

The meter should be installed in a location that does not exceed the maximum operating temperature and provides good air circulation.

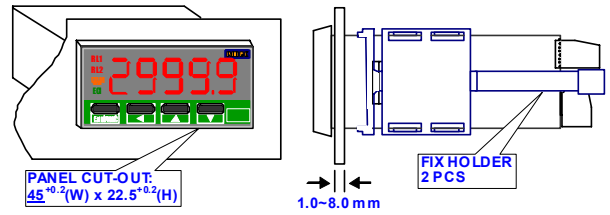

CONNECTION DIAGRAM

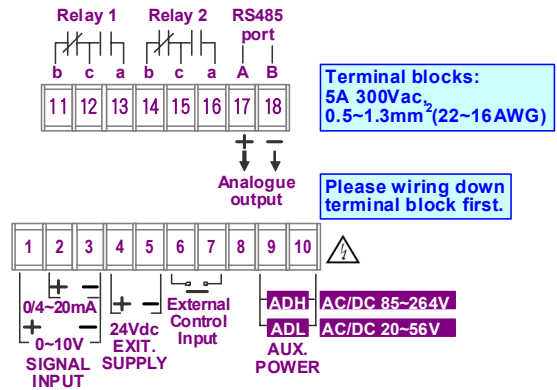

Please check the voltage of power supplied first, and then connect to the specified terminals. It is recommended that power supplied to the meter be protected by a fuse or circuit breaker.

Power Supply

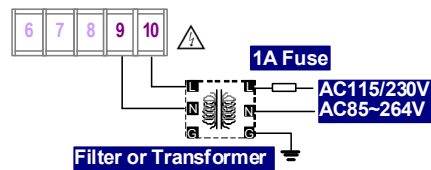

2 wire Transmitter connection

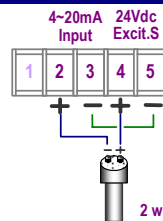

4~20mA source connection

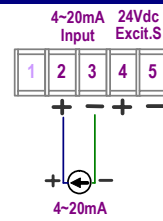

RS485 Communication Port

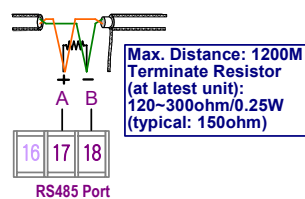

FUNCTIONS DESCRIPTION

Input & Scaling Functions

Dual input types: (Option Code: AV)

Voltage and Current type are in one unit available in option. If the customer specify the input coding for AV, the meter will be calibrated for 0~10V and 0~20mA in factory. The user can use in 0~10V and 4(0)~20mA by difference terminals connection(#1 & #3 for 0~10V or #2 & #3 for 4(0)~20mA) and programming in [R L O] of [I N P U T G R O U P] .

Input range:

The meter has to be specified and fixed according to ordering code (ex. 0~10V or 4(0)~20mA) in factory. If the meter has to install in difference range of input, the meter can be set in function [R L O] and [R H I] in [I N P U T G R O U P] to meet the input signal. For example: The meter is 0~10Vdc input, and the signal from sensor is 2~10Vdc. Please get into [I N P U T G R O U P] to set [R L O] (Analogue input Low) to be 20.00%(10V x 20.00% = 2V), then the meter has been changed the input range to 2~10Vdc and the all relative parameters will work base on 2~10V. The meter doesn't need re-calibration after change the [R L O] and [R H I] .

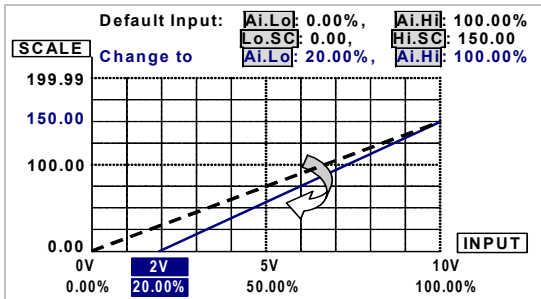

*The setting may cause display lower resolution. Please set lower resolution when the input signal has been high compressed.

Square root function:

The function can be set [NO] or [YES] in [I N P U T G R O U P] to measure the signal from differential pressure flow-meter. The formula = $\sqrt{(Pv/HS) \times HS}$

Scaling function:

The high and low of display range can be programmable to relative input signal high and low. Setting the [Lo.Sc] (Low scale) and [Hi.Sc] (High scale) in [I N P U T G R O U P] to relative input signal. Reverse scaling will be done too. Please refer to the figure as below,

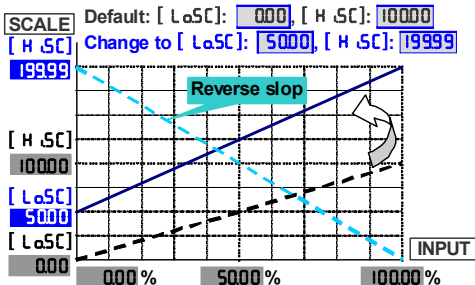

Display & Functions

Max / Mini recording:

The meter will storage the maximum and minimum value in [User Level] during power on in order to review drifting of PV.

Display functions:

(Please refer to step A-10)

PV / Max(Mini) Hold / RS 485 programmable in [D S P L Y] function in [I N P U T G R O U P]

Present Value [P V]: The display will show the value that relative to Input signal.

Maximum Hold [M A X H] / Minimum Hold [M I N H]:

The meter will keep display in maximum (minimum) value during power on, until manual reset by front key in [User Level], [E.C.I] close by rear terminal (according to setting, please refer to the function of E.C.I. Group) or or press front up key to Reset (Up key set to be same function as ECI1)

➤ Please find the [E.C.I] sticker that enclosure the package of the meter to stick on the left side of square orange LED.

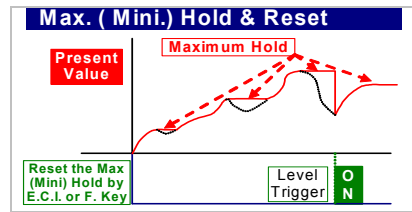

Remote Display by RS485 command [r 5485]: The meter will show the value that received from RS485 command. In past, The meter normally receive 4~20mA or 0~10V from AO or digital output from BCD module of PLC. We support a new solution that PV shows the value from RS485 command of master can so that can be save cost and wiring from PLC.

PV Hold [P V H L D]: [E.C.I] can be set to be [P V H L D] function (Please refer to the function of ECI Group). The display will be hold, when the E.C.I. is closed.

➤ Please find the [E.C.I] sticker to stick on the left side of square green LED.

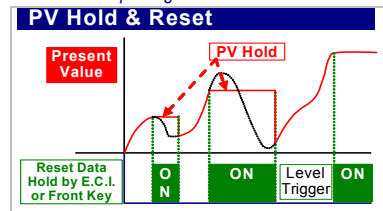

Low cut:

If the setting value is positive, it means when the absolutely value of PV ≤ Setting value, the display will be 0. If the setting value is negative, it means when the PV under setting value (PV ≤ -Setting value), the display will be setting value.

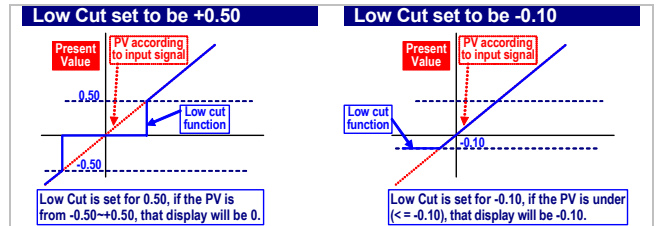

Digital fine adjustment:

Users can get Fine Adjustment for Zero & Span of PV by front key of the meter, and "Just Key In" the value which user want to show in the current input signals. Especially, the [P u P r o] & [P u S p n] are not only in zero & span of PV, but also any lower point for [P u P r o] & higher point for [P u S p n]. The meter will be linearization for full scale. The adjustment can be clear in function [P S C L r] .

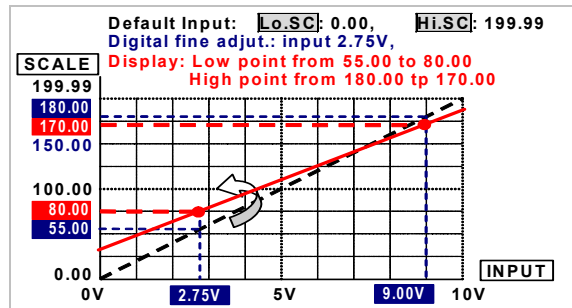

Reading Stable Function

Average:

Basically, the sampling rate of meter is 15cycles/sec. If the function set to be 3 times, It means the meter will update of display will be 5 times/sec.

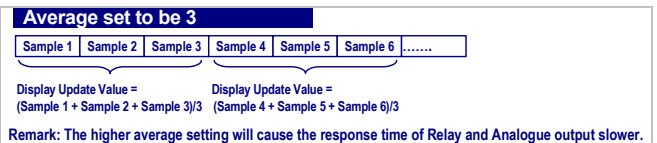

Moving average:

If the function to be set 3 times, the meter will update delay in first 3 samples, then it will update 15 times/sec. continuously.

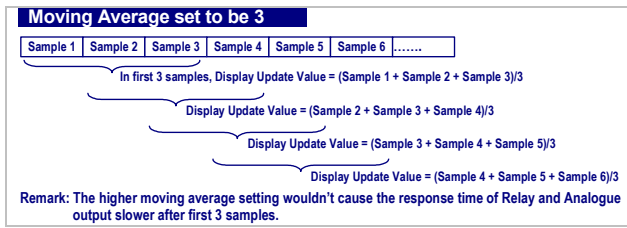

Digital filter:

The digital filter can reduce the magnetic noise in field.

Control Functions(option)

Relay energized mode:

In all CS series, the relay functions are not only for alarm or control, but also for I/O interface as like as I/O of PLC. They can be programmed to be Hi(Latch) / Lo(Latch) energized to compare with set-point or DO to be energized by RS485 command directly.

Energized with set-points:

Hi / Lo / Hi.HLd / Lo.HLd programmable

Hi: Relay will energize when PV > Set-Point

Lo: Relay will energize when PV < Set-Point

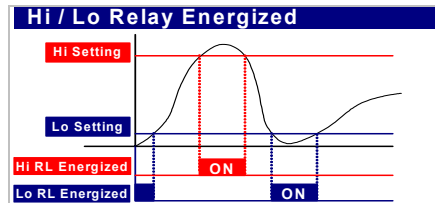

Hi.HLd (Lo.HLd): When the PV Higher (or lower) than set-point, the relay will be energized and latch until manual reset by from key in **[User Level]**, up key (If up key function has been set) or **[E.C.I.]** close by rear terminal.

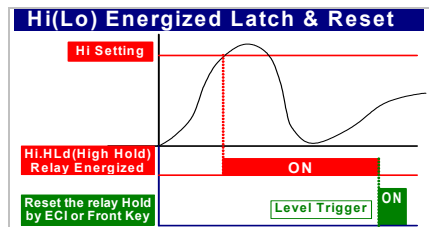

Energized by RS485 command of master: DO function

The DO function was designed to get remote control by RS485 command of master. The typical application is to control a switch in field from computer center as like as digital output(DO) of PLC.

Energized functions: Start delay / Energized & De-energized delay / Hysteresis

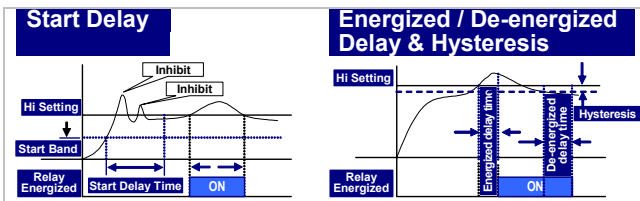

External Control Inputs(ECI)

The one external control input is programmable to perform specific meter control or display functions. The E.C.I. has been designed in level trigger actions. Please pay attention, the ECI input will be disable while UP or Down Key has been set to be "YES".

Functions:

Relative PV / PV Hold / Reset Max or Mini. Hold / DI / Reset for Relay Energized latch; programmable

Relative PV or Tare: The E.C.I. can be set to be **[RELPU]** function. When the E.C.I. is closed, the reading will show the differential value until it's open.

PV Hold: The E.C.I. can be set to be **[PVHLd]** function. The display will be hold when the E.C.I. is closed, until the E.C.I. is to be open. Please refer to the figure on following;

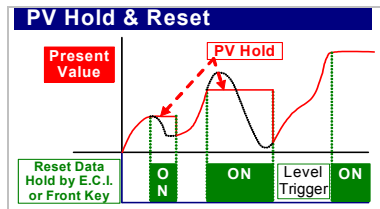

Reset for Maximum or Minimum Hold: When the **[dSPly]** function in **[mPUt GrOuP]** selected **[MAXH]** or **[MINH]**, the display will show Maximum or Minimum value, and can be reset by the E.C.I. Please refer to the figure as below;

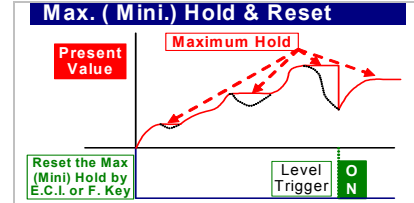

DI: The E.C.I. can be set to be **[di]** function. when the meter build in RS485 port, It is easier to get remote monitoring a switch status through the meter as like as DI of PLC.

Reset for Relay Energized Latch: If relay energized mode has set to be Energized latch **[Hi.HLd]** / **[Lo.HLd]**, the E.C.I. can be set to be **[Ry.RSt]**. When the PV meets the condition of relay energizing, the relay will be energized and latch until the E.C.I. is closed.

Debouncing time:

The function is for avoiding noise signal to into the meter. And The basic period is 8m seconds. It means you set the number that has to multiple 8m seconds. For example:

[dEbnc] set to be 5, it means 5 x 8m seconds = 40m seconds

Analogue output(option)

Please specify the output type either an 0~10V or 4(0)~20mA in ordering. The programmable output low and high scaling can be based on various display values. **Reverse slope output is possible by reversing point positions.**

Output range:

Voltage: 0~5V / 0~10V / 1~5V programmable
Current: 0~10mA / 0~20mA / 4~20mA programmable

Functions:

Ao.HS(output range high): setting the Display value High to versus output range High(as like as 20mA in 4~20)
Ao.LS(output range Low): setting the Display value Low to versus output range Low(as like as 4mA in 4~20)

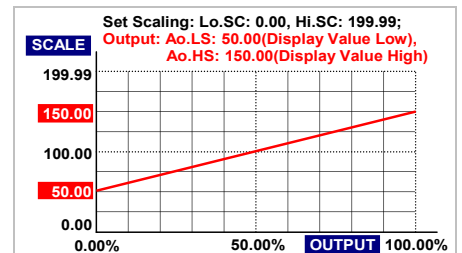

The range between **Ao.Hs** and **Ao.LS** should be over 20% of span at least; otherwise, it will be got less resolution of analogue output.

Ao.LMt(output High Limit): 0.00~110.00% of output High

User can set the high limit of output to avoid a damage of receiver or protection system.

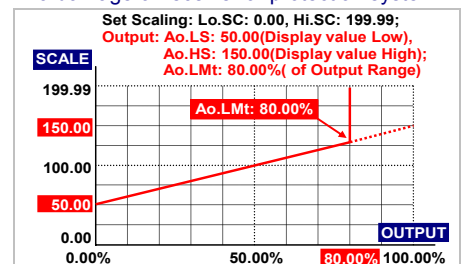

Fine zero & span adjustment:

Users can get Fine Adjustment of analogue output by front key of the meter. Please connect standard meter to the terminal of analogue output. To press the front key(up or down key) of meter to adjust and check the output.

- [R0Zr0] : Fine Zero Adjustment for Analogue Output;
Settable range: -38011~27524;
- [R0SPn] : Fine Span Adjustment for Analogue Output;
Settable range: -38011~27524;

RS 485 Communication(option)

The RS485's protocol is Modbus RTU mode, and baud rate up to 38400 bps. It's not only convenience to remote monitoring, display for reading and ECI status, but also for remote control in the case that doesn't have any DIO device in the field.

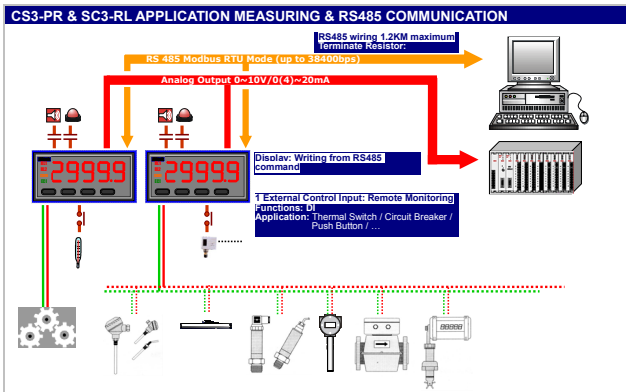

Remote display:

to show the value from RS485 command of master

The meter will show the value that received from RS485 command. In past, The meter normally receive 4~20mA or 0~10V from AO or digital output from BCD module of PLC. We support a new solution that PV shows the value from RS485 command of master so that can be **save cost and wiring** from PLC.

When the [dSPly] set to be RS485, it means, the PV screen will show the value from RS485 command & data. The data(number) will be same as PV that will compare with set-point, analogue output and ECI functions so that is to control analogue output, relay energized and so on.

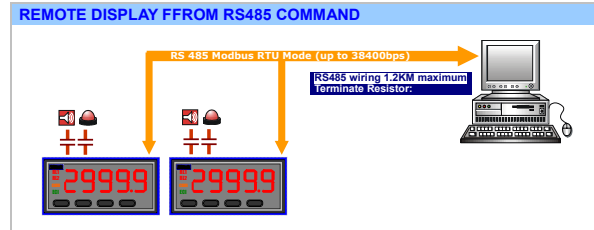

Calibration

System calibration by front key. The process of calibration, please refer to the operating manual

■ ERROR MASAGE

DESCRIPTION	DISPLAY	FLASH	REMARK
BEFORE POWER ON, PLEASE CHECK THE SPECIFICATION AND CONNECTION AGAIN.			
SELF-DIAGNOSIS AND ERROR CODE:			
ouFL : Display is positive-overflow (Signal is over display range)	ouFL		(Please check the input signal)
-ouFL : Display is negative-overflow (Signal is under display range)	-ouFL		(Please check the input signal)
ouFL : ADC is positive-overflow (Signal is higher than input high 20%)	ouFL		(Please check the input signal)
-ouFL : ADC is negative-overflow (Signal is lower than input low 20%)	-ouFL		(Please check the input signal)
EEP / FAiL : EEPROM occurs error	EEP	FAiL	(Please send back to manufactory for repaired)
AiL.nG / Pu : Calibrating Input Signal do not process	AiL.nG	Pu	(Please process Calibrating Input Signal)
AiL. / FAiL : Calibrating Input Signal error	AiL.	FAiL	(Please check Calibrating Input Signal)
AO.nG / Pu : Calibrating Output Signal do not process	AO.nG	Pu	(Please process Calibrating Output Signal)
AiL. / FAiL : Calibrating Output Signal error	AiL.	FAiL	(Please check Calibrating Output Signal)

FRONT PANEL:

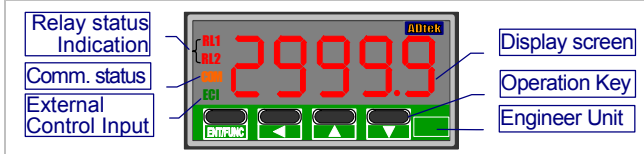

Numeric Screens

0.4"(10.0mm) red high-brightness LED for 4 2/3 digital present value.

I/O Status Indication

- **Relay Energized:** 2 square red LED
RL1 display when Relay 1 energized;
RL2 display when Relay 2 energized;
- **External Control Input Energized:** 1 square green LED
ECI1 display when E.C.I. 1 close(dry contact)
- **RS485 Communication:** 1 square orange LED
COM will flash when the meter is receive or send data, and **COM** flash quickly means the data transient quicker.

Stickers:

Each meter has stickers what are functions and engineer label enclosure.

- **Relay energized mode:** **HH Hi Lo LL DO**
- **E.C.I. functions mode:**
PV.H PV.H(PV Hold) / **Tare** Tare / **DI** DI(Digital Input) /
M.RS M.RS(Reset for Maximum or Minimum hold) /
R.RS R.RS(Reset for Relay Latch)
- **Engineer Label:** over 80 types.

- **Operating Key:** 4 keys for **ENTR** Enter(Function) / **ESC** Shift(Escape) / **UP** Up key / **DOWN** Down key

	Setting Status	Function Index
UP key	Increase number	Go back to previous function index
DOWN key	Decrease number	Go to next function index
ESC key	Shift the setting position	Go back to this function index & abort the setting
ENTR key	Setting Confirmed and save to EEPROM	From the function index to get into setting status

- **Pass Word:** Settable range:0000~9999;
 User has to key in the right pass word so that get into **[Programming Level]**. Otherwise, the meter will go back to measuring page. If user forgets the password, please contact with our service window.
- **Function Lock:** There are 4 levels programmable.
 - **None:** no lock all.
 - **User Level:** User Level lock. User can get into User Level for checking but setting.
 - **Programming Level:** Programming level lock. User can get into programming level for checking but setting.
 - **ALL:** All lock. User can get into all level for checking but setting.
- **Front Key Function**
 - The **UP** Key can be set to be the same function as the setting of ECI1.
 Ex. The ECI1 set to be **PuHLd** and the function E.1=UP set to be **YES** in **[ECI GroUP]**. When user presses **UP** Key, the PV will hold as like as ECI1 close.
 - **If the front key function has been set, the terminal input for ECI will be disabling.**

OPERATING DIAGRAM(The detail description of operation, please refer to operating manual.)

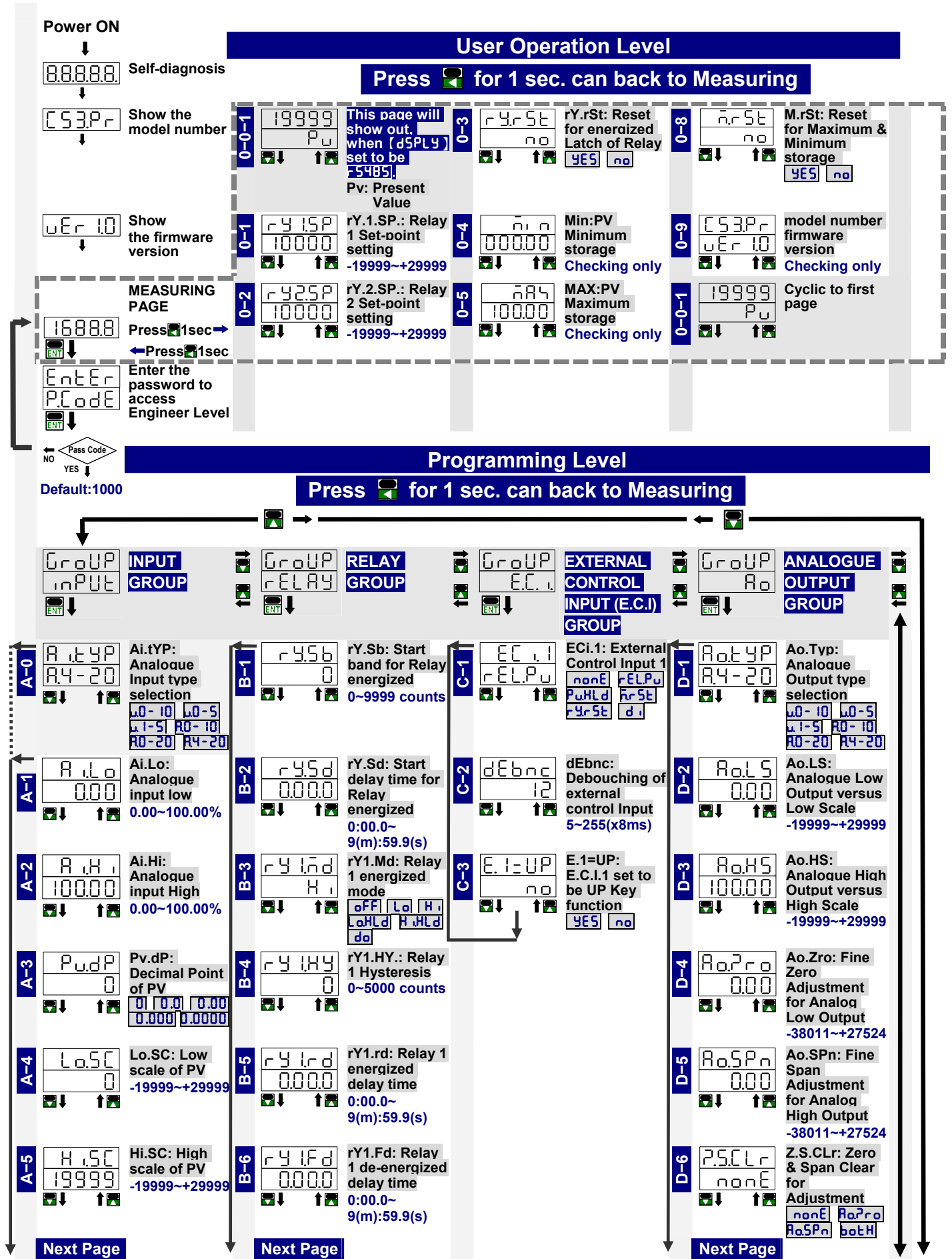

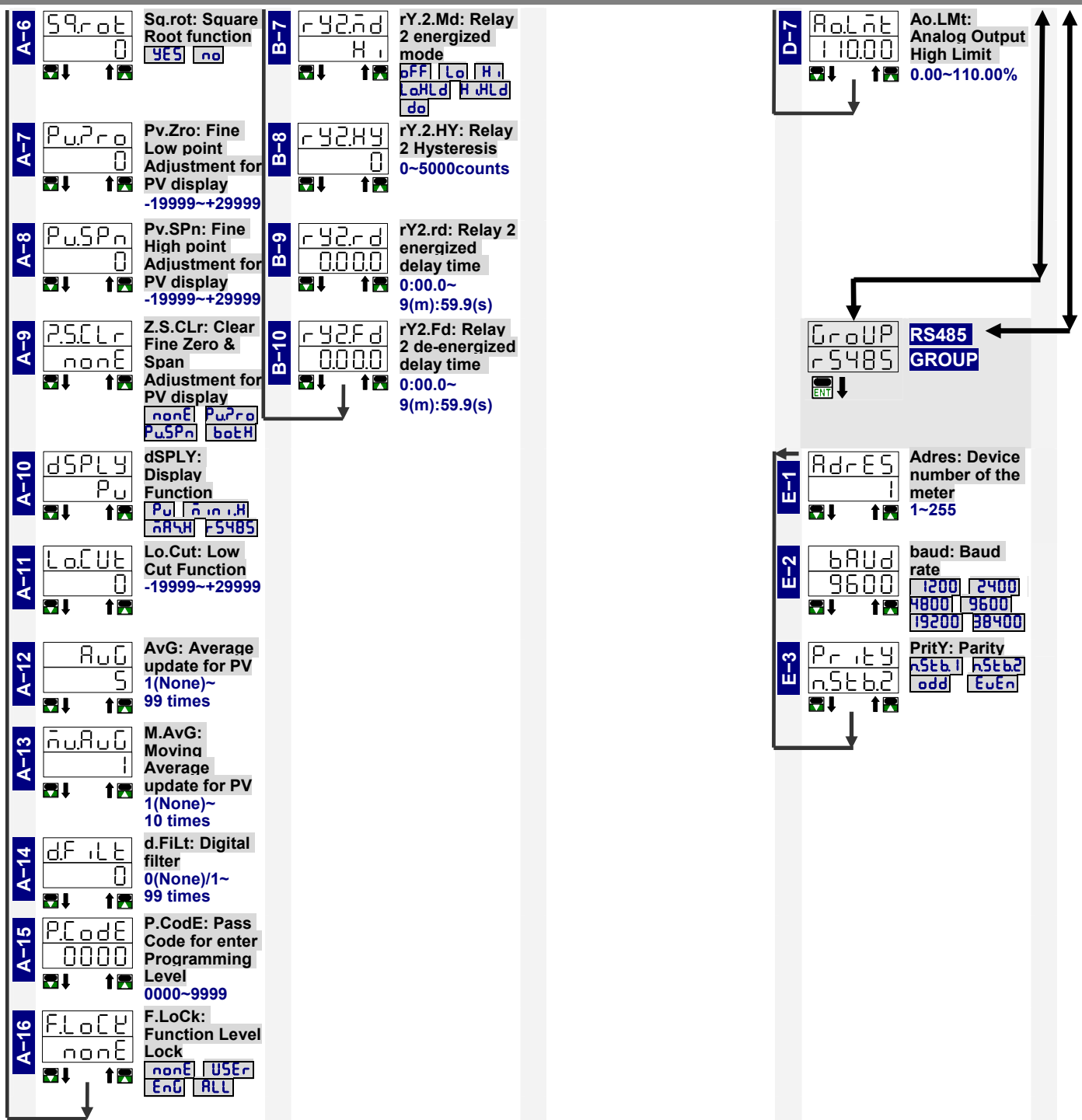

➤ PLesae refer to operating manual for detail description